

DRG NO

176.23.005B/F

ISSUE MODIFICATION DATE

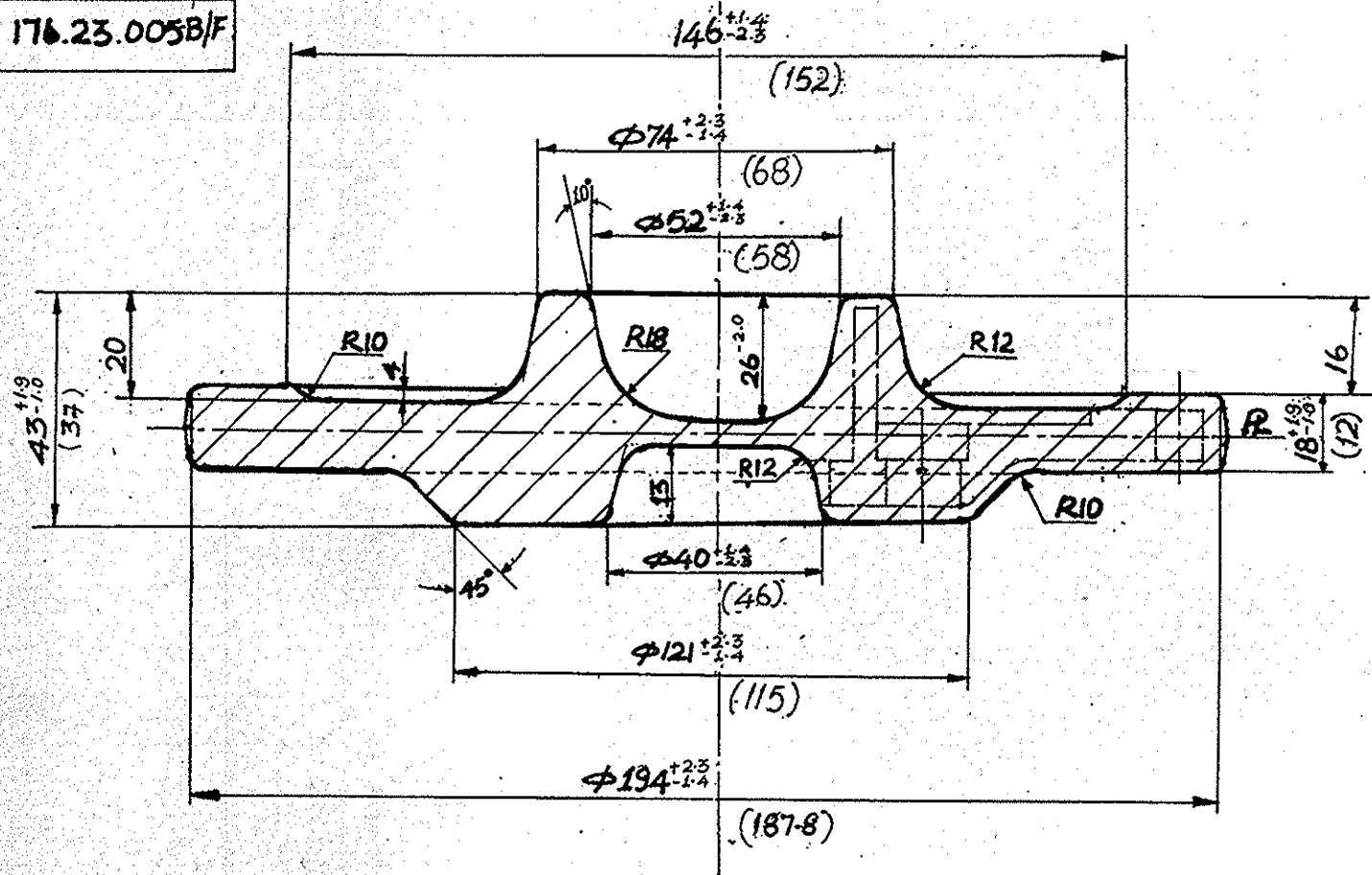

TECHNICAL REQUIREMENTS.

HEAT TREAT. DIA OF IND. ≥ 38
 DESCALE.
 DEPTH OF SURFACE DEFECTS UPTO 0.5
 OF ACTUAL MACHINING ALLOWANCE
 IS ACCEPTABLE.
 MISMATCH SHOULD NOT EXCEED 0.07MM.
 RESIDUAL FIN ALONG PARTING PLANE
 SHOULD NOT EXCEED 1.2 MM.
 UNTOLERANCED DIMENSIONS ARE FOR
 CONSTRUCTION.
 MARK PART NO.
 MAY BE MANUFACTURED FROM STEEL
 38XC GOST 4543-71
 UNSPECIFIED DRAFTS ARE TO BE 7°
 UNSPECIFIED RADII ARE TO BE ≥ 30 MM.
 MACHINING DIMENSIONS ARE SHOWN IN
 BRACKETS

MATERIAL :- STEEL 38XC GOST 4543.71

FORGING WEIGHT : 5.0Kg

SCALE	COMPONENT - T72	MACHINE	COMPONENT / FORGING
1:1	176-23-005B/F AUXILIARY : GEAR	D66	
DGN.	CHD	AUTH	APPD.
FORGING DRAWING			H.V.F AVADI. DRAWING. No
			176-23-005B/F