

CERTIFIED-CORRECT-COPY  
 OF THE ORIGINAL DRAWING  
 DATE: 26/03/2019  
 26/03/19

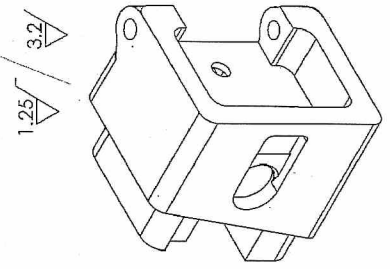
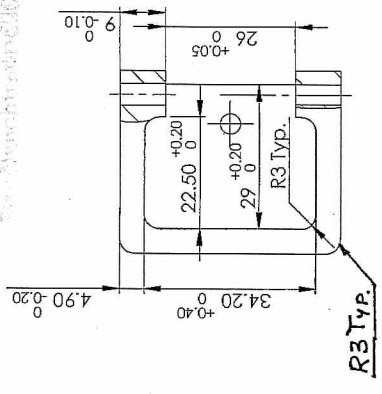
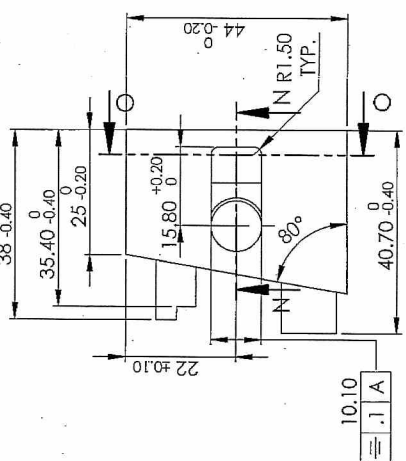
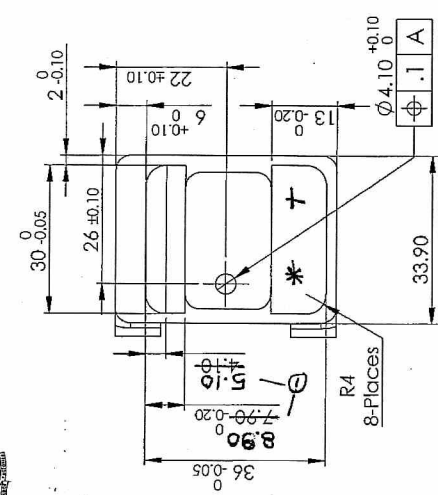
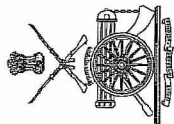

**Material:- Steel**  
 BS:970 Pt.1 1983 Gr 817 M40 (ot)En-24  
 BS:970 Pt.1 1983 Gr 709 M40 (ot)En-19  
 BS:970 Pt.1 1983 Gr 708 M40 (ot)En-19A

**Material for Casting:-**  
 BS:3146 PART-1, 1974 Class:5 , Grade:A  
 Non Stressed Component

Radiographic Test as per ASTM-E-192  
**Acceptance Standard:-**  
 Gas hole & Foreign Material: Level-3  
 Shrinkage (All Types) : Level 3

**Note:- for Casting**  
 Tolerance as per IS:11166 Class-I  
 Flatness Tolerance :  $\pm 0.1 / 25.4$  mm  
 Casting Radius 0.5 mm  
 Hardness: 290-350 HV

**Protective Finish:**  
 Accelerated Phosphating to Specn.  
 JSS: 0465-01-1994 Class II Oil Finish

Unilateral Dimens. as per IS:2102 (MED)

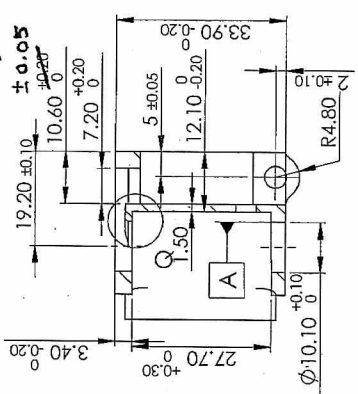
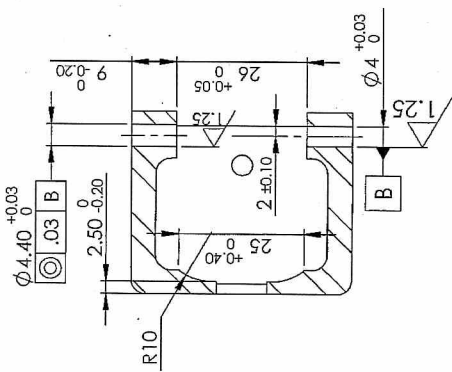

DRG. No.: <b>TEND-2616 *3</b> DES. REF. NO. : <b>K4002</b> DRG. No.: <b>*3</b>		SIGNATURE & DATE: P. Teyan C. K.	SUB: <b>PMB -Trunnion</b> FOR: <b>TRUNNION</b> OF: <b>TRICHY ASSAULT RIFLE</b> DES. REF. NO. : <b>K4002</b> DRG. No.: <b>*3</b> TEND-2616 <b>ORDNANCE FACTORY TIRUCHIRAPPALLI - 16.</b> 	SCALE: <b>NTS</b> OPG: <b>1</b> Weight(g): <b>229.16</b> SHEETS: <b>1</b> SHEET No.: <b>1</b>
DA. No. 5/100 # DF.: 25/15/20 DI.: 04/1/20 DA. No. 13/2020 DI. 24.01.2020	TRACED DRAWN CHECKED OIC/D&DO OFFICER/ PRODN. DIV. OFFICER/ D&DO			

**MARKING:-**  
 \* MANUFACTURER CODE  
 † BATCH / YEAR OF MANUFACTURE  
 ENGRAVING DEPTH 0.1MM & HEIGHT 3MM.