

OFB

THIS DRAWING/DRAWING SHEET CONTAINS COMPANY PROPRIETARY INFORMATION. USE OR DISCLOSURE IN WHOLE OR IN PART SHALL NOT BE MADE WITHOUT THE WRITTEN PERMISSION OF OFB

176-8135

MOUNTING BY TACKS ONLY

A

A

176-8137

5 ± 1

60 ref

143 ref

23° ref

4 PLC

176-8131

176-8133

176-8132

176-8134

SECTION A-A

संदर्भ हेतु
For REFERENCE
JW/DO..... 63-05-18



NOTES:

1. According to SHARANG Specn. No. 208
2. PWHT, According to SHARANG Specn. No. 208S

DATE	01.01.2007	ALTERNATIVE/INDICATED MATERIAL SPECN. condition (SIT) CQA(W) JABALPUR I No. SH-10-24-CQA(W) 011	190	JAWA/DO
				DR. 12 JULY, 2005

DRAWING SEALED BY/DO (COA/W)	18914-W	CQA (W), JABALPUR	APPROVED	DO/DO INITIALS	DATE	SCALE	SIZE	ASSEMBLY	176-8001	PART NO	SHARANG 130/155MM_UG_OFR_SIB	UPDATED	SH: of	1-2	A3																
	DI. 6 - 6 - 2005											SCALE	1-2	A3																	
MACHINING INSTRUCTIONS												FINISH		SAND BLAST AND PAINTING		MATERIAL		SI		NAME		BASE ARM									
UNSPECIFIED TOLERANCES FOR DIMENSIONS AND ANGLES												STRESS RELEASE AFTER WELDING		PART NO		SHARANG 130/155MM_UG_OFR_SIB		SCALE		1-2		A3		ASSEMBLY		176-8001		PART NO		176-8130	
HEAT TREATMENT												FINISH		SAND BLAST AND PAINTING		MATERIAL		SI		NAME		BASE ARM		DEVELOPMENT CENTRE, CQA, JABALPUR		PART NO		176-8130			



THIS DRAWING/DOCUMENT CONTAINS
CONFIDENTIAL INFORMATION
USE OR DISCLOSURE IN WHOLE OR
IN PART SHALL NOT BE MADE
WITHOUT THE WRITTEN PERMISSION
OF OFB

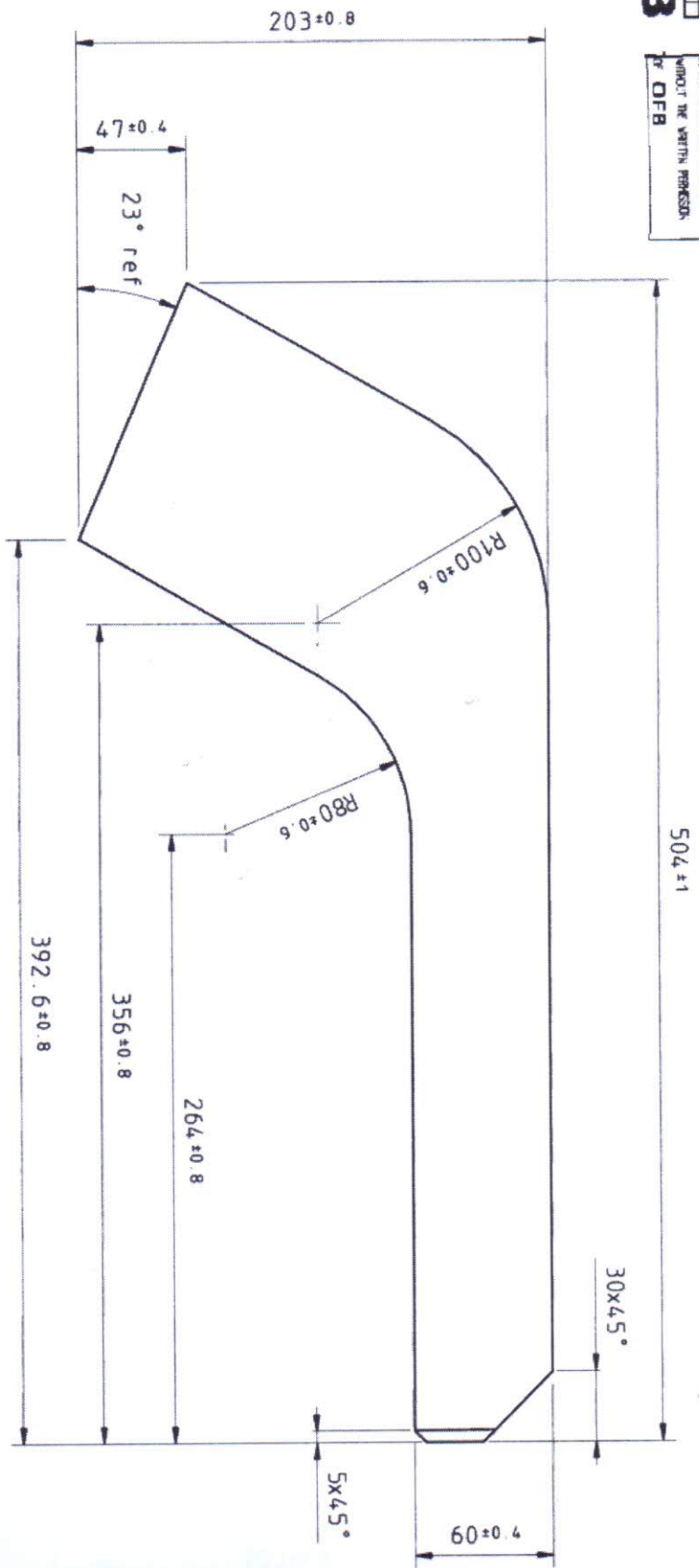

व्यापारिक अधिकार
FOR TRADE SUPPLY
JMM/DO.....

Signature
06/04/18

JMM/SID. CLK
VIEW A
SCALE 2:1

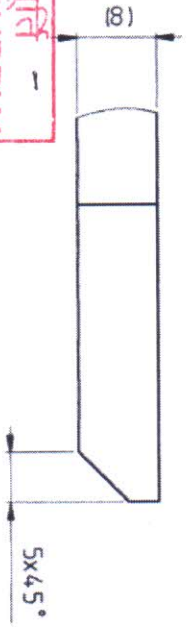

MACHINING INSTRUCTIONS 25/		I.D. No. 2120 Location: 01/06/01		DATE: 01.01.2007	ALTERNATIVE INDUSTRY MATERIAL SPEC BS-970 P4-83 GDE 150 M19 heat treated to "P" condition OR BS-1448 P4-83 GDE 60-85 CS (REF: COA(W) JABALPUR LSN. 3B2402COA(W)011 DN 12 JULY 2005)	DRAWING SEALED Dr. G-6-2005	18914-W
UNDESIRABLE TOLERANCES FOR DIMENSIONS AND ANGLES		PART NO.	SHARANG 130/155MM_LUG_OF8_SIB	DRAWING NO.		COA (W), JABALPUR	Dr. G-6-2005
HEAT TREATMENT		ASSEMBLY	T76-8130 (T76-8001)	MATERIAL		515x215	DATE: 01.01.2007
FINISH		NAME		SIDE WEB		PLATE 8 mm DIN 1543 S152-3	Dr. G-6-2005
FINISH		NAME		SIDE WEB		PLATE 8 mm DIN 1543 S152-3	Dr. G-6-2005
FINISH		NAME		SIDE WEB		PLATE 8 mm DIN 1543 S152-3	Dr. G-6-2005

Table-2

6



OFB

THIS DRAWING/DOCUMENT CONTAINS COMPANY PROPRIETARY INFORMATION. USE OR DISCLOSURE IN WHOLE OR IN PART SHALL NOT BE MADE WITHOUT THE WRITTEN PERMISSION OF OFB

(473)

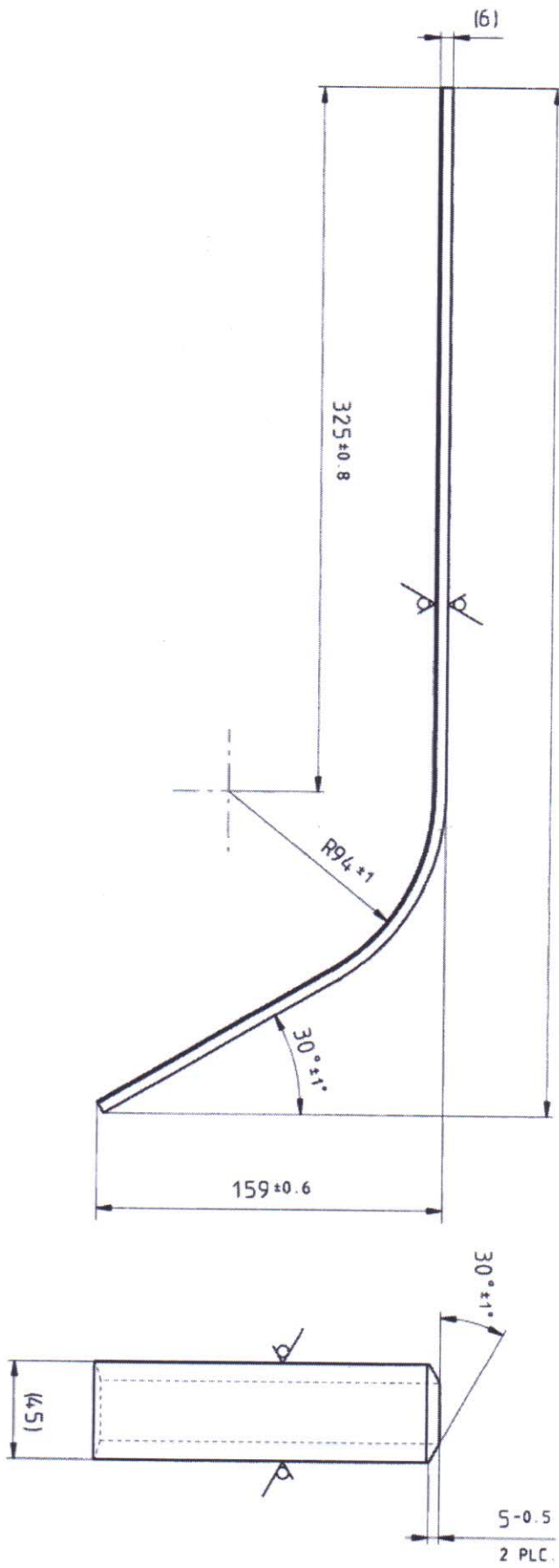

STRAIGHT STOCK = 560 mm

व्यापारिक आपूर्ति
FOR TRADE SUPPLY
 JMM/DO
 01/06/18

25 (✓)		MACHING INSTRUCTIONS UNSPECIFIED TOLERANCES FOR DIMENSIONS AND ANGLES		I.D. No. 2122 Location: 01/06/18		DATE: 01.01.2007 ALTERNATIVE/INDIGENOUS MATERIAL SPEC: BS 970 P4-L83 GDE 120 M19 Hot rolled & normalized OR BS 1449 P4-L83 GDE 60-65CS (REF: COA(W) JABALPUR LNO. 38240DCQAW/011 DN 12 JULY 2005)	
HEAT TREATMENT		SHARANG 130/155MM_UG_OFB_SIB		18914-11 Dt. 6-6-2006		DRAWING SEALED BY DO (COA(W))	
FINISH		ASSEMBLY 176-8130 (176-8001)		COA (W), JABALPUR		191	
MATERIAL L=560 FLAT 45x6 DN 1077-S137-2		NAME UPPER COVER		12 A3		DEVELOPMENT CENTRE, UPL, NARRAN	
PART NO. 176-8133		DEVELOPMENT CENTRE, UPL, NARRAN		APPROVED BY: JMM/DO		DATE: 01/06/18	

6



OFB

THIS DRAWING/DOCUMENT CONTAINS COMPANY PROPRIETARY INFORMATION. USE OR DISCLOSE IN WHOLE OR IN PART SHALL NOT BE MADE WITHOUT THE WRITTEN PERMISSION OF OFB.

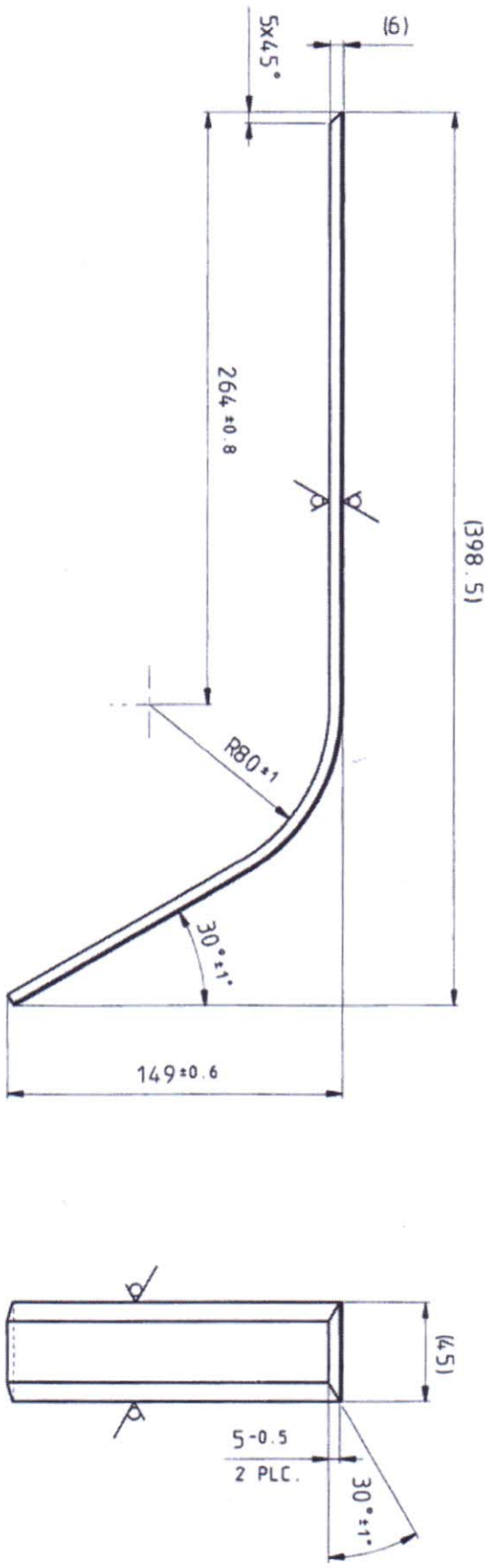

STRAIGHT STOCK = 480 mm

व्यापारिक आपूर्ति
For TRADE SUPPLY
 JWM/sd. COA
 02/11/18
 JWM/DO.....

MACHING INSTRUCTIONS		25 (V)	
ISSUED FOR DESIGN & NO. CHANGES		SHARANG 130/155MM_UG_OFB_SIB	
HEAT TREATMENT		PART NO.	
FINISH		ASSEMBLY 176-8130 (176-8001)	
MATERIAL L=480 FL 45x6 DIN 1017-S1 37-2		NAME BOTTOM COVER	
I.D. No. 2123 Location: 01/06/01		/8914-W Dt. 6-6-2005	
COA (W), JABALPUR		DRAWING SEALED COA(W)	
DATE: 01.01.2007		ALTERNATE/INDIGENOUS MATERIAL SPEC: BS 970 Pt-483 GDE 120 M19 Hot rolled & normalized (REF: COA(W), JABALPUR L.No. SB240/COA(W)011 Dk. 12.28.17.2005)	
APPROVED		APPROVED	
DRAWN		CHECKED	
DATE		DATE	
SCALE		SCALE	
SHEET NO. 1		SHEET NO. 1	
OF 1		OF 1	
PART NO. 176-8134		PART NO. 176-8134	



THIS DRAWING/DOCUMENT CONTAINS
 COMPANY PROPRIETARY INFORMATION.
 USE OR DISCLOSURE IN WHOLE OR
 IN PART SHALL NOT BE MADE
 WITHOUT THE WRITTEN PERMISSION
 OF OFB

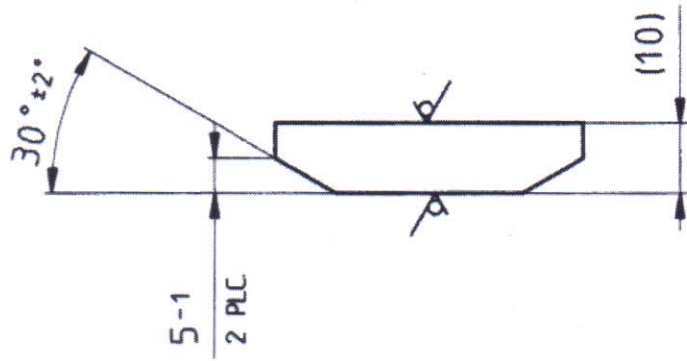
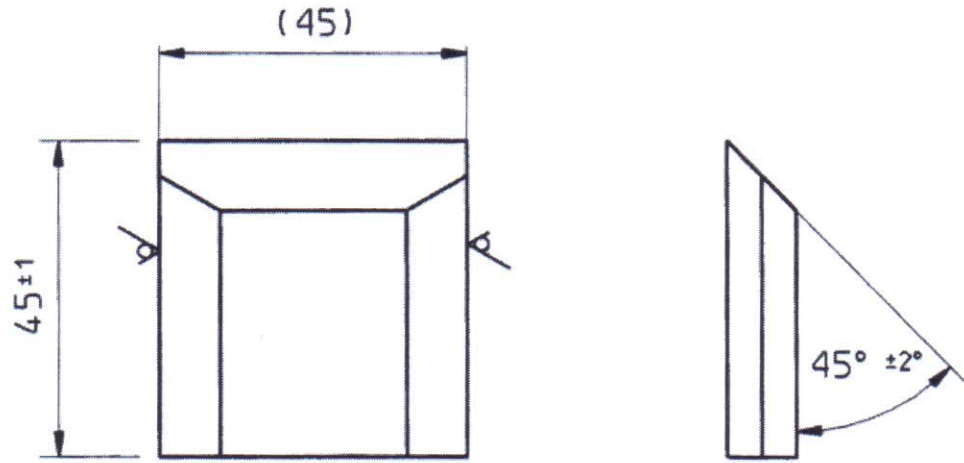

व्यापारिक आपूर्ति
For TRADE SUPPLY
 JWM/Std. Cell
D. W. 06/4/18
 JWM/DO.....

*1:11 Heat treatment
 Table - 3, 7, 12, 13, 14*

12.5/ (✓)

DATE: 01.01.2007	ALTERNATE/ INDIGENOUS MATERIAL SPCN: BS:970 Pt-1:83 GDE 120 M19 Hot rolled & normalized <i>Table-9 Sec. 2.1 Cserg</i> (REF: CQA(W) JABALPUR LNo. 3B2402/CQAW/011 Dt. 12 JULY 2005)	195 <i>[Signature]</i> JWM/CDD
---------------------	--	--------------------------------------

18914-W
 Dt. 6-6-2005
 DRAWING SEALED
 CQA (W), JABALPUR

MACHINING INSTRUCTIONS
 UNSPECIFIED TOLERANCES FOR DIMENSIONS AND ANGLES
 DIMENSIONS
 ANGLES
 HEAT TREATMENT
 FINISH
 MATERIAL
 L=45
 Flat 45x10 DIN 1017-st.37-2

SHARANG 130/155MM_UG_OFB_SLB		UPDATED	
PART NO.		Sh: 1	of: 1
ASSEMBLY 176-8130 (176-8001)		1:1	A4
NAME FRONT COVER		SCALE	SIZE

PREP'D	<i>[Signature]</i>
CHK'D	<i>[Signature]</i>
JWM/DO	<i>[Signature]</i>
APPROVED	
<i>[Signature]</i>	<i>[Signature]</i>
DO/DO	DIR/ODC
ORDNANCE DEVELOPMENT CENTRE, OFC, KANPUR	
PART NO.	176-8135



OFB

THIS DRAWING/DOCUMENT CONTAINS
COMPANY PROPRIETARY INFORMATION.
USE OR DISCLOSURE IN WHOLE OR
IN PART SHALL NOT BE MADE
WITHOUT THE WRITTEN PERMISSION
OF OFB

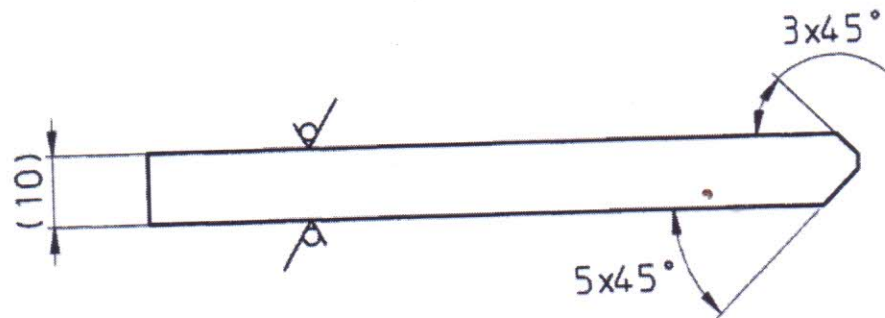
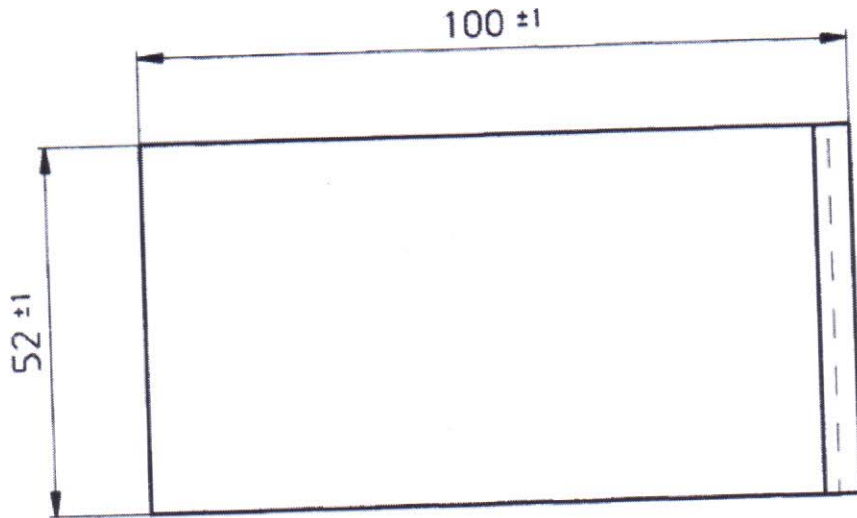

व्यापारिक आपूर्ति
For TRADE SUPPLY
JWM/Std. Cell
06/4/18
JWM/DO.....

DRAWING SEALED BY DO
COA(W)

18914-W
Dt. 6-6-2005

CQA (W), JABALPUR

12.5 / (✓)

MACHINING INSTRUCTIONS

UNSPECIFIED TOLERANCES
FOR DIMENSIONS AND ANGLES

ANGLES

HEAT TREATMENT

FINISH PHOSPHATE COATING ACCORDING
TO DOD-P-16232 TYPE M CL.2

MATERIAL 107 X 60
PLATE 10 mm DIN 1543
St. 52-3

DATE:
01.01.2007

ALTERNATE/ INDIGENOUS MATERIAL SPN:
BS:970 Pt-I:83 GDE 150 M19 heat treated to "P"
condition.
(REF: CQA(W) JABALPUR LNo. 3B2402/CQAW/011
Dt. 12 JULY 2005)

197
[Signature]
JWM/CDD

SHARANG 130/155MM_UG_OFB_SLB

PART NO.

UPDATED

Sh:
of:

1:1

A4

SCALE

SIZE

ASSEMBLY 176-8130 (176-8001)

NAME

DOUBLER

PREP'D	<i>[Signature]</i>
CHKD	<i>[Signature]</i>
JWM/DO	<i>[Signature]</i>
APPROVED	
<i>[Signature]</i>	<i>[Signature]</i>
DO/DO	DIR/ODC

ORDNANCE
DEVELOPMENT CENTRE
OFC, KANPUR

PART NO. 176-8137

