

907000-3367 D.S. CAT. NO. 4933-000406

DRAWING CONVENTIONS CONFORM TO JSG-0104  
DIMNS. ARE IN m.m. GEN. TOL. 'MEDIUM' IS: 2102

MARKING ON TAG.  
Yr. OF Mfg.  
MANUFACTURER'S CODE  
D.S.CAT. NO.

ALL SHARP EDGES TO BE ROUNDED TO 0.5 R EXCEPT THE EDGE MARKED 'P'

MATERIAL :-  
MATERIAL TO SPECN. BS:1449 PT.1:1983 -  
GD CS 60 IN HARDENED & TEMPERED CONDITION  
TO ACHIEVE SPECIFIED HARDNESS

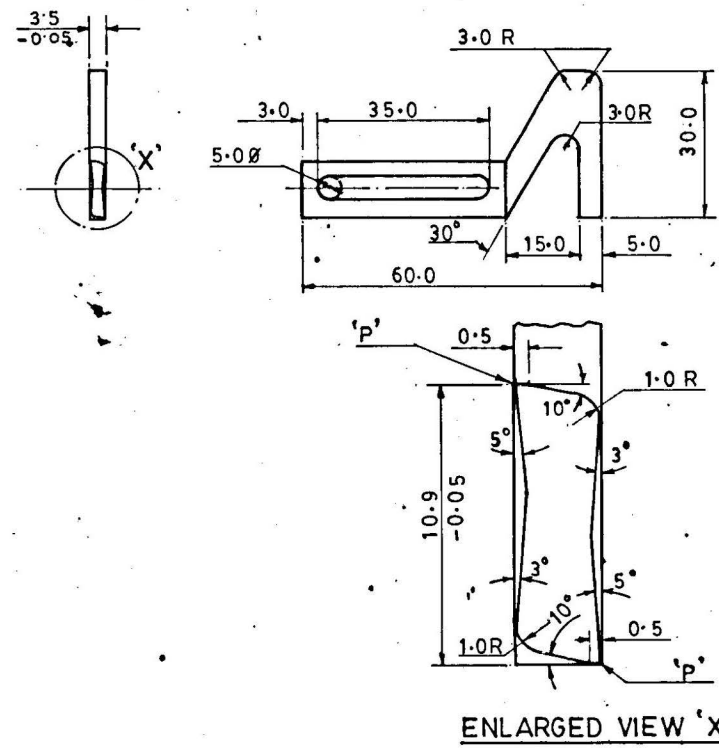

NSN: B214933-72-0001406

09.09.16	26937-SA	MATERIAL AMENDED.		DRN.	CHD.	TRD.	COMP.	AHSP CQA(SA), ICHAPUR
08-7-10	26519-SA	NSN ADDED		SCALE :- 1:1		EST. MASS		ASSY.
03-04-99	24-310-SA	ALTERNATIVE MATERIAL ADDED		DT. 19-1-98	Anles 1/C;D.O.	APPROVED DT. 2.1.91		NEG. RE-TRACED
19-1-98	24031-SA.	PROFORMA CHANGED, MARKING NOTE ADDED, NEG. RE-TRACED AND DRG. PROV. RE-SEALED.						DG NR'S REF. ARDE/TA/94/28
		PREVIOUS DC. NOS. 23764-SA, 23918-SA.						PART NO.
DATE AUTHY.		BRIEF RECORD	ZONE	1/C;D.O	G.O.	H.T./HARDNESS :- 350 TO 400 H.V.		DRG. NO.
SEALED :- PROV. DC. NO. 23764-SA, DT. 21.3.97			SIGN.		PROTECTIVE PHOSPHATE TO SPECN. JSS:0465-01-1988		D.S.CAT. 4933-000406	
NOMENCLATURE :- TOOL CLEANING GAS BLOCK					FINISH :- CLASS II (ACCELERATED), OIL FINISH.		NO.	