

VISUAL INSPECTION - THE FINISH COMPONENT SHALL BE FREE FROM TOOL MARKS AND ANY OTHER SURFACE DEFECTS.

PACKING :- EACH SHACKLE SHALL BE SEALED IN A POLYETHYLENE BAG. 15 SUCH BAGS MAY BE PACKED IN A CCBC WITH SUITABLE LABEL.

MARKING : EACH SHACKLE SHALL BE MARKED AS: ADRDE / (YEAR OF MFG./ .. OF 15/SET...

ITEM No.	NOMENCLATURE	QTY.	SHEET No.	DRG./ SPEC.No
05	SPLIT PIN 2 X 32	01	-	IS549-1974
04	SPACER	01	05	1417 04
03	HEX. NUT	01	04	1417 03
02	HEX. BOLT	01	03	1417 02
01	BODY	01	02	1417 01
-	ASSEMBLY	01	01	1417

ITEM LIST

TOLERANCE :- AS PER IS2002 (PART-1) 1993; MEDIUM UNLESS OTHERWISE SPECIFIED

SCALE:- 1:1	QTY :- 1	A D R E AGR	DRN.	SK SHARMA
DIMENSIONS IN MM	TOL :- AS ABOVE	GROUP -HDS	CHKD.	J.C.DUTTA
MATERIAL:-	FINISH:-	ASSEMBLY		
HEAT TREATMENT:-		CLAMP (SHACKLE)		
		GH D SYSTEM FOR AN-32 A/C		

PROOF LOAD TEST :- Samples may be tested for Proof Load test at 4000kgf.

Ref No.	DATE	ZONE	AUTHORITY	2
				3
				4

APPROVED  
PROJ.DR./GP.DR  
DRG. INCHARGE /1417

PROOF LOAD 4000 kgf

Marking Place to be marked by manufacturer

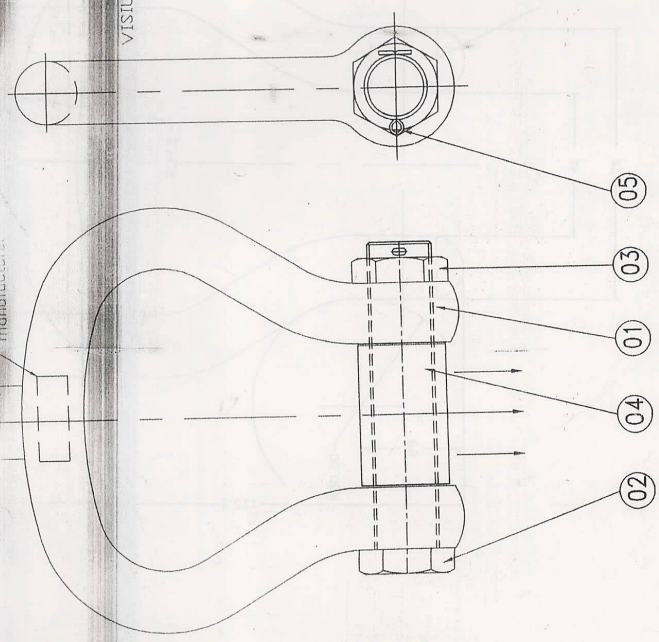

VISUAL INSPECTION : THE FINISH COMPONENT SHALL BE FREE FROM HULL MARKS AND ANY OTHER SURFACE DEFECTS.

PACKING :- EACH SHACKLE SHALL BE SEALED IN A POLYETHYLENE BAG. 15 SUCH BAGS MAY BE PACKED IN A CCBC WITH SUITABLE LABEL.

MARKING : EACH SHACKLE SHALL BE MARKED AS: ADRDE / (YEAR OF MFG./ .. OF 15/SET)..

05	SPLIT PIN 2 X 32	01	--	IS:549-1974
04	SPACER	01	05	1417 04
03	HEX. NUT	01	04	1417 03
02	HEX. BOLT	01	03	1417 02
01	BODY ASSEMBLY	01	02	1417 01
--		01	01	1417
ITEM No.	NOMENCLATURE	QTY.	SHEET No./DRG./ SPEC.No	

ITEM LIST

TOLERANCE :- AS PER IS:2002 (PART-D) 1993; MEDIUM UNLESS OTHERWISE SPECIFIED

SCALE:- 1:1	QTY :- 1	A D R D E AGRA	DRWL.	SK SHARMA
DIMENSIONS IN MM		GROUP -HDS	CHKD.	J.C. DUTTA
TOL:- AS ABOVE		APPROVED		
MATERIAL:-		PROJ.DR/CP/DFR		
FINISH:-		ASSEMBLY		
HEAT TREATMENT:-		CLAMP (SHACKLE)		
		CH D SYSTEM FOR AN-32 A/D		
		DRG. NO. ADRDE / 1417		

PROOF LOAD TEST :- Samples may be tested for Proof Load test at 4000kgf.

Ref No.	DATE	ZONE	AUTHORITY	BRIEF RECORD





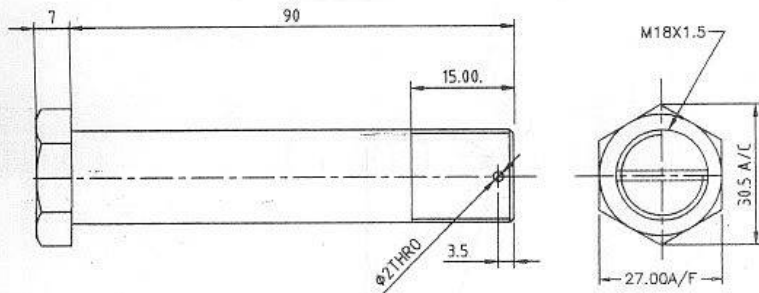

MATERIAL : STEEL ALLOY EN19/24 (709M40/817M40) AS PER BS 970  
 FINISH : CADMIUM PLATED TO MINIMUM THICKNESS 0.012 mm  
 & CHROMATE PASSIVATED TO IS 1572 : 1986 Gr.3 CL. Fe/Cd 12 CA  
 (STRESS RELIEF BEFORE PLATING, HYDROGEN EMBRITTELEMENT)  
 TOLERANCE:-IS:2.102 (PART-1) 1993 MEDIUM UNLESS OTHERWISE SPECIFIED.  
 PROCESS - FABRICATION/MACHINING

Ref.No.	DATE	ZONE	AUTHORITY	BRIEF RECORD		D I/C (D&S)	HEAD (Q.A.)
SCALE: 1:1	QTY:- 1No.		A D R D E AGRA	DRN.	SK SHARMA	<i>30/1/04</i> <i>anand sharma</i> PROJ.OFFR./GP OFFR	
DIMENSIONS IN mm		GROUP:- HDS	CHKD.	JC DUTTA	APPROVED		
TOL. :- AS ABOVE		HEX.BOLT CLAMP(SHACKLE) (H D SYSTEM FOR AN-32 A/C)		PROJ.DIR./GP DIR 6/7/04 PROJ.DIR./GP DIR		APPROVED	
MATERIAL:- AS ABOVE						APPROVED	
FINISH:- AS ABOVE						APPROVED	
HEAT TREATMENT:- 32±5 HRC						APPROVED	
		ORG. NO. ADRDE/1417-02					



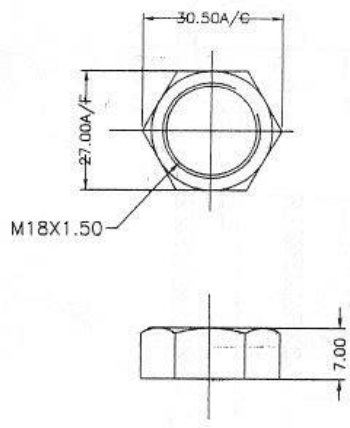

MATERIAL : STEEL ALLOY EN19/24 (709M40/817M40) AS PER BS 970  
 FINISH : CADMIUM PLATED TO MINIMUM THICKNESS 0.012 mm  
 & CHROMATE PASSIVATED TO IS 1572 : 1986 Gr.3 CL. Fe/Cd 12 CA  
 (STRESS RELIEF BEFORE PLATING, HYDROGEN EMBRITTLEMENT)  
 TOLERANCE:-IS:2002 (PART-1) 1993 MEDIUM UNLESS OTHERWISE SPECIFIED.  
 PROCESS - FABRICATION/MACHINING

Ref.No.	DATE	ZONE	AUTHORITY	BRIEF RECORD		D I / C (D&S)	HEAD (Q.A.)
SCALE : 1:1	QTY:- 1 No.	A D R D E A G R A		DRN.	SK SHARMA	 PROJ.OFFR./GP OFFR APPROVED  PROJ.DIR./GP DIR DRG. NO. ADRDE/14-17-03	
DIMENSIONS IN mm		GROUP:- HDS		CHKD.	JC DUTTA		
TOL. :- AS ABOVE		HEX. NUT CLAMP(SHACKLE) (H D SYSTEM FOR AN-32 A/C)					
MATERIAL:- AS ABOVE							
FINISH:- AS ABOVE							
HEAT TREATMENT:- 32±5 HRC							

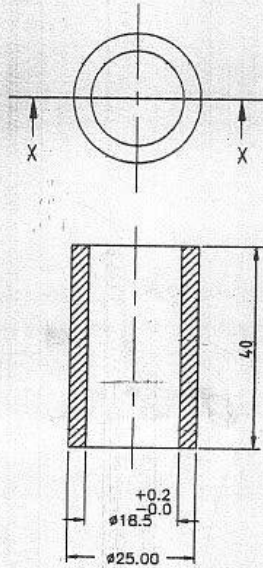

MATERIAL : STEEL ALLOY EN19/24 (709M40/817M40) AS PER BS 970  
 FINISH : CADMIUM PLATED TO MINIMUM THICKNESS 0.012 mm  
 & CHROMATE PASSIVATED TO IS 1572 : 1986 Gr.3 CL. Fe/Cd 12 CA  
 (STRESS RELIEF BEFORE PLATING, HYDROGEN EMBRITTELEMENT)  
 TOLERANCE:-IS:2402 (PART-1) 1993 MEDIUM UNLESS OTHERWISE SPECIFIED.  
 PROCESS - FABRICATION/MACHINING

Ref.No.	DATE	ZONE	AUTHORITY	BRIEF RECORD		O/C (D&S)	HEAD (Q.A.)
SCALE : 1:1	QTY:- 1No.		ADRDE AGRA	DRN.	SK SHARMA	<i>[Signature]</i>	<i>[Signature]</i>
DIMENSIONS IN mm			GROUP:- HDS	CHKD.	JC DUTTA		
TGL :- AS ABOVE			<b>SPACER</b> CLAMP(SHACKLE) (H D SYSTEM FOR AN-32 A/C)		APPROVED		<i>[Signature]</i> 6/7/04 PROJ.DIR./GP DIR
MATERIAL:- AS ABOVE					PROJ.OFFR./GP OFFR		
FINISH:- AS ABOVE					DRG. NO. ADRDE/1417-04		
HEAT TREATMENT:- 32±5 HRC							