

SK-6667 TE

D.A. NO.

Hos/mm
 आरक्षक को सही प्रमाणित
 प्रतिलिपि दिनांक
 03/01/2024 correct copy
 J. Works Manager
 DPO

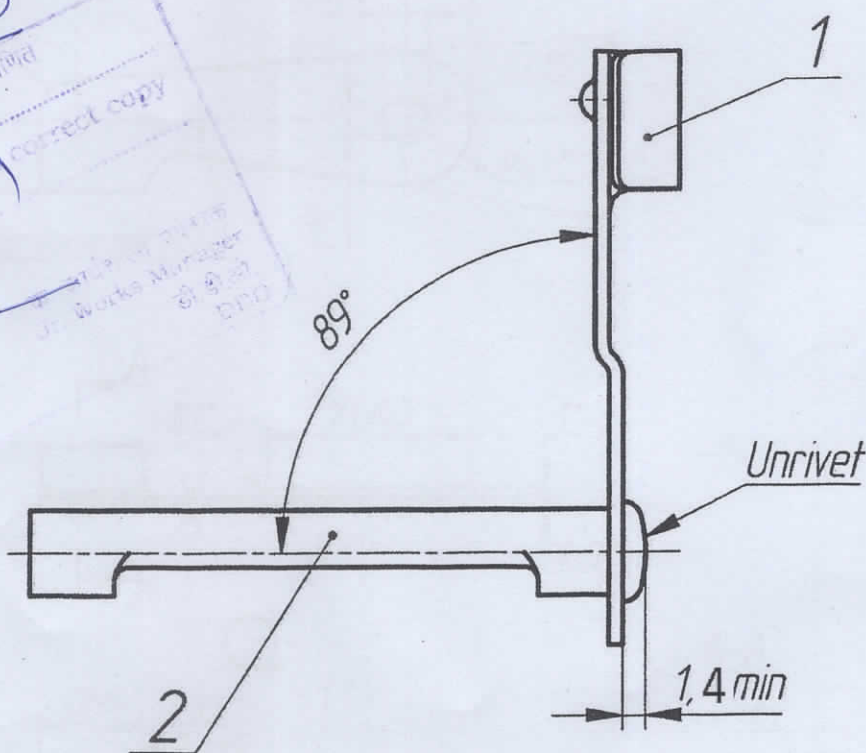

S.NO.	NOMINCLATURE	DRG. NO.
1.	Retainer	SK-6668 TE
2.	Retainer Pin	SK-6669 TE

Coating is Chem. Phos. chr/impreg. with BΦ-4 glue GOST 12172-2016 with nigrosine of grade A GOST 9307-78.

WEIGHT : 12 g

7.62 X39 mm AR-SAF

Cover retainer
Assembly drawing

DRAWN	TRACED	CHECKED
S P SONI		
DATE	03.01.2024	
APPROVED		
HOS/DDO		

SCALE
N.T.S.

SMALL ARMS FACTORY
KANPUR

DRG. NO.	SK-6667 TE
SHT. 1 OF 1	

SK-6668 TE

D.A. NO.

√ Rz 40 (✓)

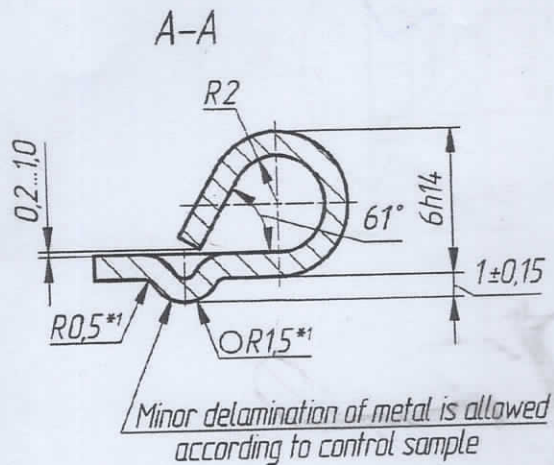
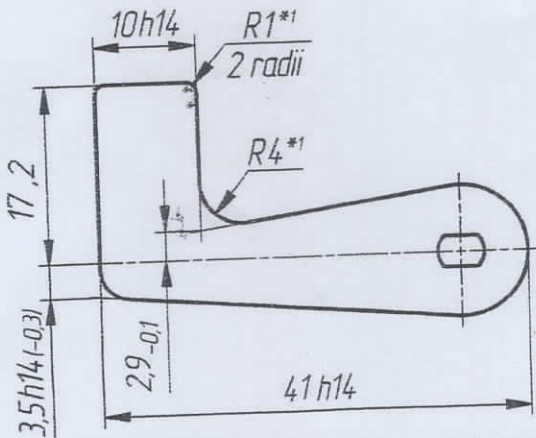
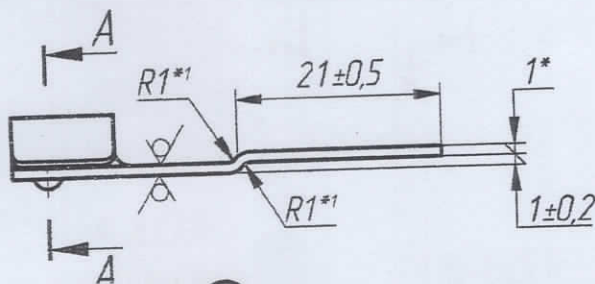
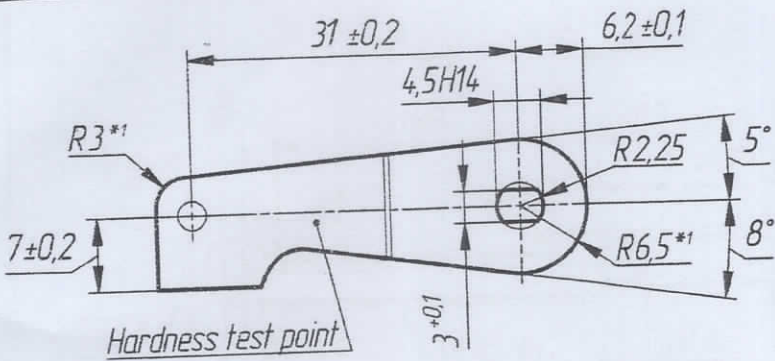

1 71...74 HRA. At hardness test point local smoothing of surface is allowed at depth up to 0,1 mm.

2 * Reference dimension.

3 *1 Dimensions to be ensured by tool.

4 Unspecified tolerances according to 6П45-1.СДТ4/Е2.

5 Stamp K, V on lot label.

MATL. Sheet BT-БШ-БД-ПН-НО-1 GOST 19904-90
K490B4-11-50 GOST 16523-97

WEIGHT: 4 g

7.62 X39 mm AR-SAF Retainer

DRAWN	TRACED	CHECKED
SP SONI		
DATE	03.01.2024	
APPROVED		

HOS/DDO

DRG. NO.

SK-6668 TE

SCALE

N.T.S.

**SMALL ARMS FACTORY
KANPUR**

SHT. 1 OF 1

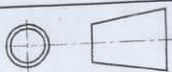

SK-6669 TE

D.A. NO.

$\sqrt{Rz\ 20\ (\checkmark)}$

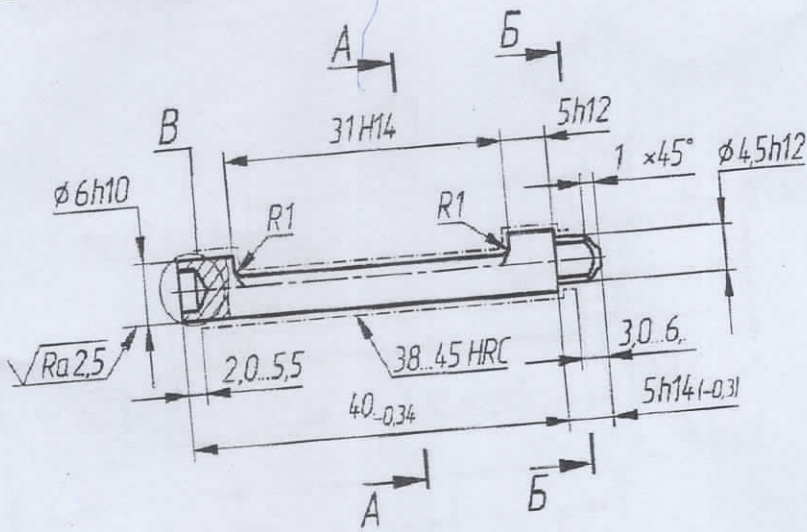

Handwritten: Hos/MSD
 03/01/24
 Certified
 S

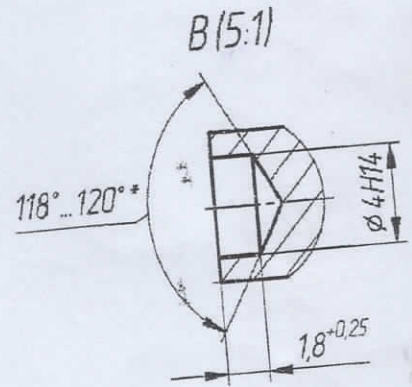
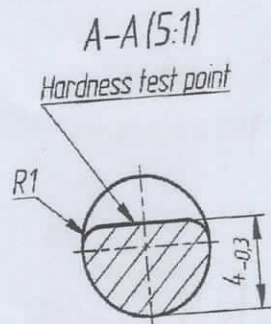

- 1 * Dimension to be ensured by tool.
- 2 Unspecified tolerances according to 6П45-1.С8Т9/Е2.

MATL:- Steel 50 GOST 1050-2013

WEIGHT : 9g

7.62 X39 mm AR-SAF Retainer Pin

DRAWN	TRACED	CHECKED
SP SONI		
DATE	03.01.2024	
APPROVED		

HOS

DRG. NO.

SK-6669 T

SCALE

N.T.S.

**SMALL ARMS FACTORY
 KANPUR**

SHT. 1 OF

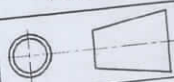

SK-6669 TE

$\sqrt{Rz} 20 (\checkmark)$

D.A. NO.

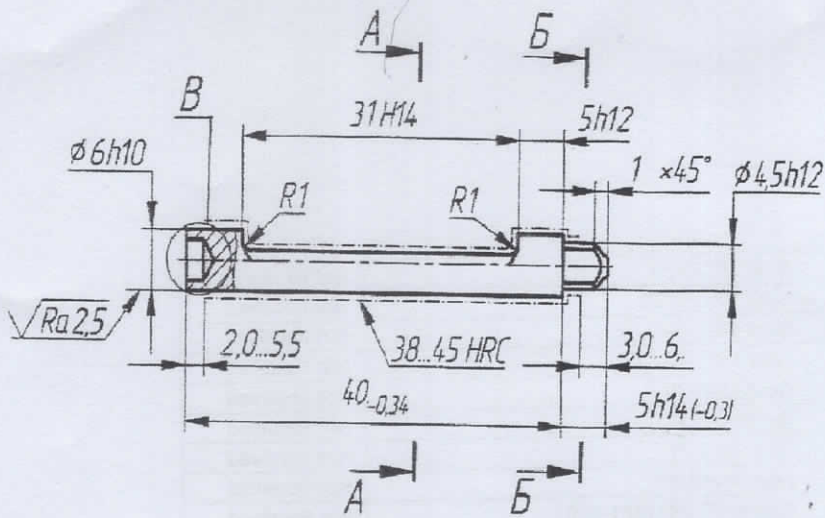

HOS/MSD
 03/01/24
 8

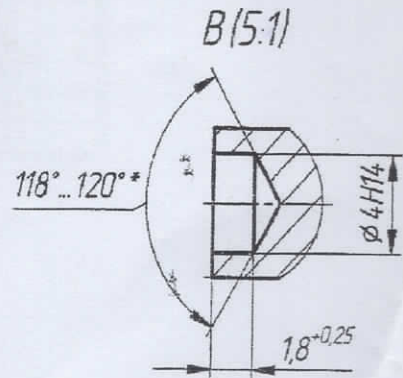
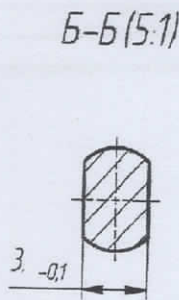
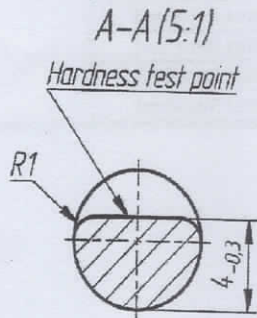

- 1 * Dimension to be ensured by tool.
- 2 Unspecified tolerances according to 61745-1.C8TY/E2.

MATL:- Steel 50 GOST 1050-2013

WEIGHT: 9g

7.62 X39 mm AR-SAF Retainer Pin

SCALE	
N.T.S.	

**SMALL ARMS FACTORY
 KANPUR**

DRAWN	TRACED	CHECKED
SP SONI		
DATE	03.01.2024	
APPROVED		
HOS		
DRG. NO.	10	
SK-6669 T		
SHT.	1 OF	