

### MACHINED COMPONENTS (GROUP -IV)

SI No	LF No	Drawing No	Nomenclature
1	6106401050	172.40.146	RING ENGAGING EXTREME RIGHT
2	6106401051	172.40.147	INITIATING RING MIDDLE R.H
3	6106401052	172.40.148	ENGAGING RING EXTREME LH
4	6106401053	172.40.149	ENGAGING RING MIDDLE, LH
5	6106401065	172.40.225	RELEASE RING III FRICTION CLUTCH
6	6101040031	172.40.225-1	3RD FRICTION CLUTCH RELEASING RING
7	6106401068	172.40.229	BOOSTER INNER
8	6106401070	172.40.231	BOOSTER
9	6106401071	172.40.232	BOOSTER
10	6106401084	172.40.246	EPICYCLE OF TRAIN IV
11	6106401085	172.40.247	GEAR CROWN 3RD PLANETARY GEAR SET
12	6106401096	172.40.270	BOOSTER
13	6101040033	172.40.270-1	BOOSTER
14	6106401097	172.40.271	CROWN
15	6106401098	172.40.308	DISCHARGE RING
16	6101040041	172.40.308-1	RELEASE RING
17	6101040042	172.40.309	CROWN GEAR OF 2ND PLANETARY GEAR SET
18	6101040043	172.40.310	CROWN GEAR OF 3RD PLANETARY GEAR SET
19	6101040044	172.40.311	EPICYCLIC GEAR OF 4TH PLANETARY SET
20	6101040052	172.40.319	DRUM
21	6101040053	172.40.320	CROWN
22	6101040054	172.40.321	BOOSTER
23	6101040055	172.40.322	INNER BOOSTER
24	6101040056	172.40.323	INNER BOOSTER
25	6101040057	172.40.324	BOOSTER
26	6101040059	172.40.326	THRUST DISK
27	6101040061	172.40.328	RIGHT HAND REAR ENGAGING RING
28	6101040062	172.40.329	RIGHT-HAND MIDDLE ENGAGING RING
29	6101040063	172.40.330	LEFT HAND REAR ENGAGING RING
30	6101040064	172.40.331	LEFT-HAND MIDDLE ENGAGING RING
31	6101040108	172.40.366	STOPPING BRAKE HOUSING (RIGHT-HAND)
32	6101040109	172.40.367	STOPPING BRAKE HOUSING (LEFT-HAND)
33	6106404014	172.43.008	PACKING COVER
34	6106401118	175.40.021	HOUSING OF MAIN BRAKE RH
35	6106401119	175.40.022	HOUSING OF MAIN BRAKE L
36	6106401120	175.40.023	BOOSTER INNER
37	6106401127	175.40.025	CROWN GEAR OF 2ND PLANETARY GEAR SET
38	6106401128	175.40.026	DRUM
39	6106401126	175.40.027-2	BOOSTER OUTER
40	6106401131	175.40.030-1	BOOSTER
41	6106401132	175.40.031	THRUST DISC
42	6106401146	175.40.052	BOOSTER BODY RIGHT
43	6106401147	175.40.053	HOUSING LH BOOSTER
44	6106402034	175.41.050	HUB FAN STEEL 38XC
45	6106402035	175.41.051	PLATE PRESSURE
46	6106406229	175.45.112	TOOTHED COUPLING
47	6101041013	188.41.006	FAN HUB



### MACHINED COMPONENTS (GROUP -IV)

Sl no.	Nomenclature & drawing No.	Manufacturing technology & Testing / Inspection Facilities required to produce the item		Must be possessed by the vendor in his premises (P&M list and testing / inspection equipment list to be submitted)	May be possessed by the vendor in his premises or out sourced (Self declaration to be submitted)	FIRM Compliance (Y/N)	Remarks
1	Components as per enclosed list of Machined Components (Group IV) <i>Total items = 47 Nos</i>	TECHNOLOGY-1	Turning	CNC Turning dia 600mm suitable to accommodate component of diameter in the range of dia 250 to 600mm with 0.010mm accuracy			
			Milling & Drilling	HMC and/or VMC suitable to the components upto the size 630mm diameter with 0.010 accuracy			
			Gear Hobbing		Gear Hobbing of Mod 3 x cutting $\phi$ 400 with gear cutting accuracy of class of Din 7 or better accuracy		
		TECHNOLOGY-3	Gear Shaping		Gear Shaping of Mod 5 with gear cutting accuracy of class of Din 7 or better accuracy.		
			Hardening & Tempering		Hardening & Tempering furnace with Oil quenching facility		
			Protection coating		Oxidising Plant		
		TECHNOLOGY-4	Raw material		Firm should be capable to arrange the raw material like Forging, Casting, Bar material etc as per drawing specification and standard.		

  
**(D.SATHISH KUMAR)**  
 WM/QA(NF& QMSC)

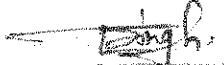
  
**(LUXMAN SINGH)**  
 WM/TRG-II, HT & EP

  
**(K.DURAIRAJ)**  
 JWM/Trans -II

Sl no.	Nomenclature & drawing No.	Manufacturing technology & Testing / Inspection Facilities required to produce the item		Must be possessed by the vendor in his premises (P&M list and testing / inspection equipment list to be submitted)	May be possessed by the vendor in his premises or out sourced (Self declaration to be submitted)	FIRM Compliance (Y/N)	Remarks	
1	Components as per enclosed list of Machined Components (Group IV)	TEST / INSPECTION-1	3D CMM	3D CMM 500 x 500mm.				
			Gear Profile Tester			Gear Profile Tester (Max module 5)		
			Surface Roughness Tester	Surface Roughness Tester for Ra & Rz values				
			Gauges	Standard Gauges for checking Holes and threads suitable to the requirement of the components. Firm should submit the undertaking in this regard that they will create the facilities within 6 months from the date of receipt of order.				
			Measuring Instruments	Gear Teeth Micrometer, Vernier Caliper, Groove Vernier, Radius gauge, Feeler Gauge etc. suitable to the requirement of the components				
		TEST / INSPECTION-2	Hardness measurement			Brinell / Rockwell Hardness Tester		

**Note : Justification for alternate facilities may be shared to prove that alternate facilities can be utilised to manufacture the item wherever the facilities are mentioned above are not available, but vendor has alternate facilities.**

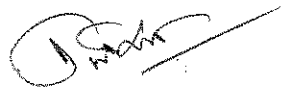
  
**(D.SATHISH KUMAR)**  
 WM/QA(NF& QMSC)

  
**(J.P.SINGH)**  
 GM-OPERATIONS I

  
**(LUXMAN SINGH)**  
 WM/TRG-II,HT & EP

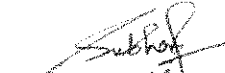
  
 Alt to **(NEERAJ KUMAR)**  
 QA-RIG(OE)

  
**(K.DURAIRAJ)**  
 JWM/Trans -II

  
**(ANIMESH PAIK)**  
 DGM/CA,TRG & RG

MATERIAL		FORGING WT.	31.0 KGS	SCALE	HAMMER	ATL. MATERIAL	DRAWN	CHECKED	APPROVED	DRAWING NO.	NOMENCLATURE:
38XC		GOST 4543-71			DG-32	NTS				172.40.270-1/F	BOOSTER
HEAVY VEHICLES FACTORY		AVADI, CHENNAI									

- TECHNICAL REQUIREMENTS**
- UN-SPECIFIED FILLET RADII - R 5
  - UN-SPECIFIED STAMPING DRAFTS - 7°
  - DIMENSIONS GIVEN IN BRACKETS ARE FOR MACHINING.
  - DIMENSIONS WITHOUT TOLERANCES ARE GIVEN FOR MAKING DIES - NEED NOT BE CHECKED.
  - MARK CODE OF SHOP - INCHARGE
  - HEAT TREATMENT ≤ 255 HB**
  - DE-SCALES (SHOT BLASTING)
  - SURFACE DEFECTS AND DEPRESSIONS DUE TO SCALES IN DEPTH MAY BE NOT MORE THAN 0.5 OF ACTUAL MACHINING ALLOWANCE.
  - SHIFT (MISALIGNMENT OF AXES OF DIES) MAY BE UPTO 1.5 MM.
  - PROJECTION DUE TO REMOVAL OF BURR ALONG THE PARTING LINE OF DIES SHOULD NOT BE MORE THAN 1.5 MM. CONTINUOUS BURR IN HOLE AND AT PLACE "A" MAY BE UPTO 4.0 MM.
  - WARPAGE MAY BE UPTO 1.5 MM.
  - ECCENTRICITY OF BROACHED HOLE MAY BE UPTO 3.5 MM.
  - PAINT RED OXIDE
- T 90

FORGING IS COMMON FOR T-90 AND T-72 COMPT. 172.40.270/F

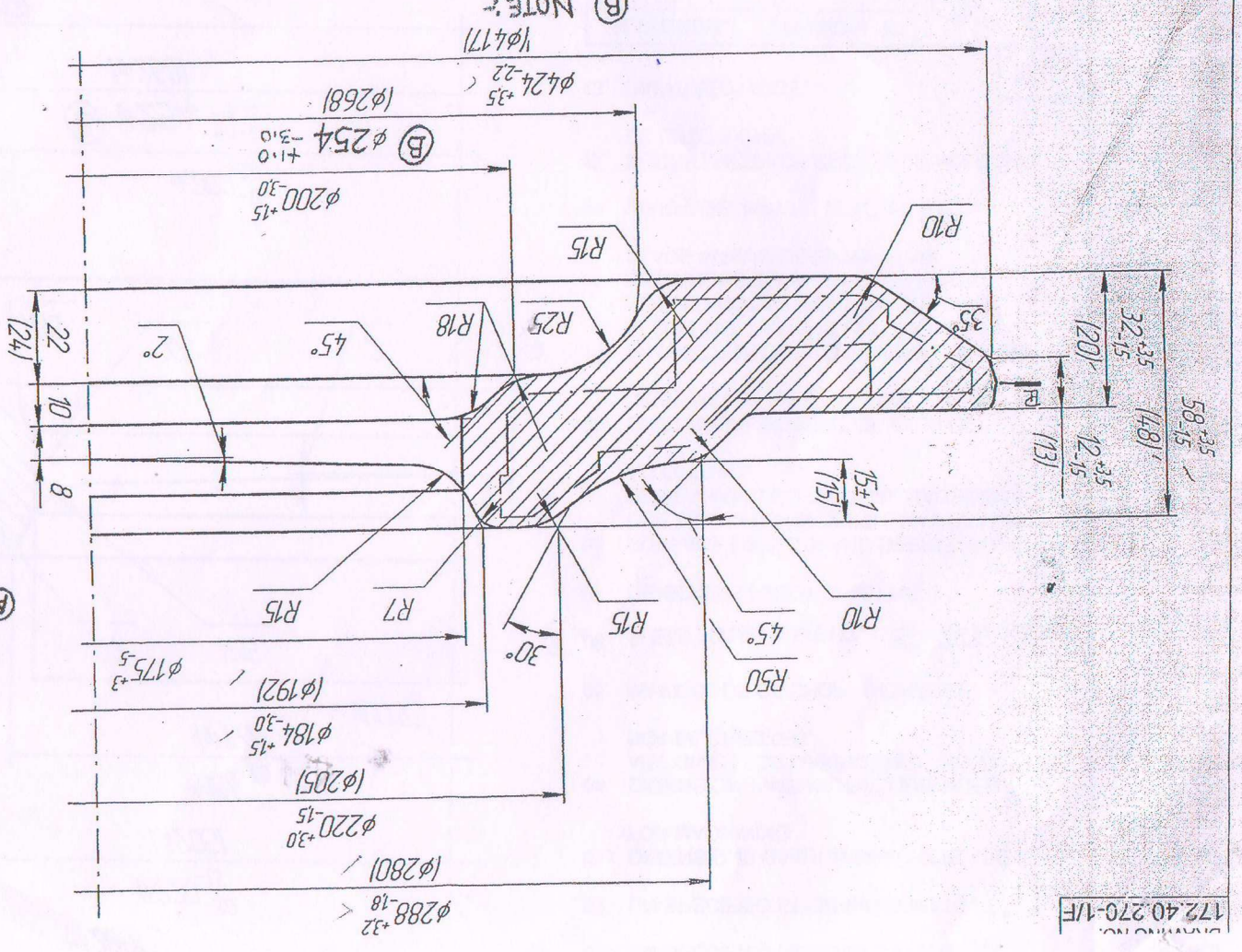

MODIFICATION	DATE
A NOTE ADDED DIA 254 WAS DIA. 260. MODIFIED AS PER IWM/TRANS/ ITR NO. 09271/TRANS/MATL. PLG/ 24/3/88	27/8/03
B HEAT TREATMENT ≤ 255HB EQUAL OR LESSER THAN 255 HB. MODIFIED IN LINE WITH T-72. AS PER IWM/FS REQUIREMENT D.P. 2007.	27/8/03

172.40.270-1/F

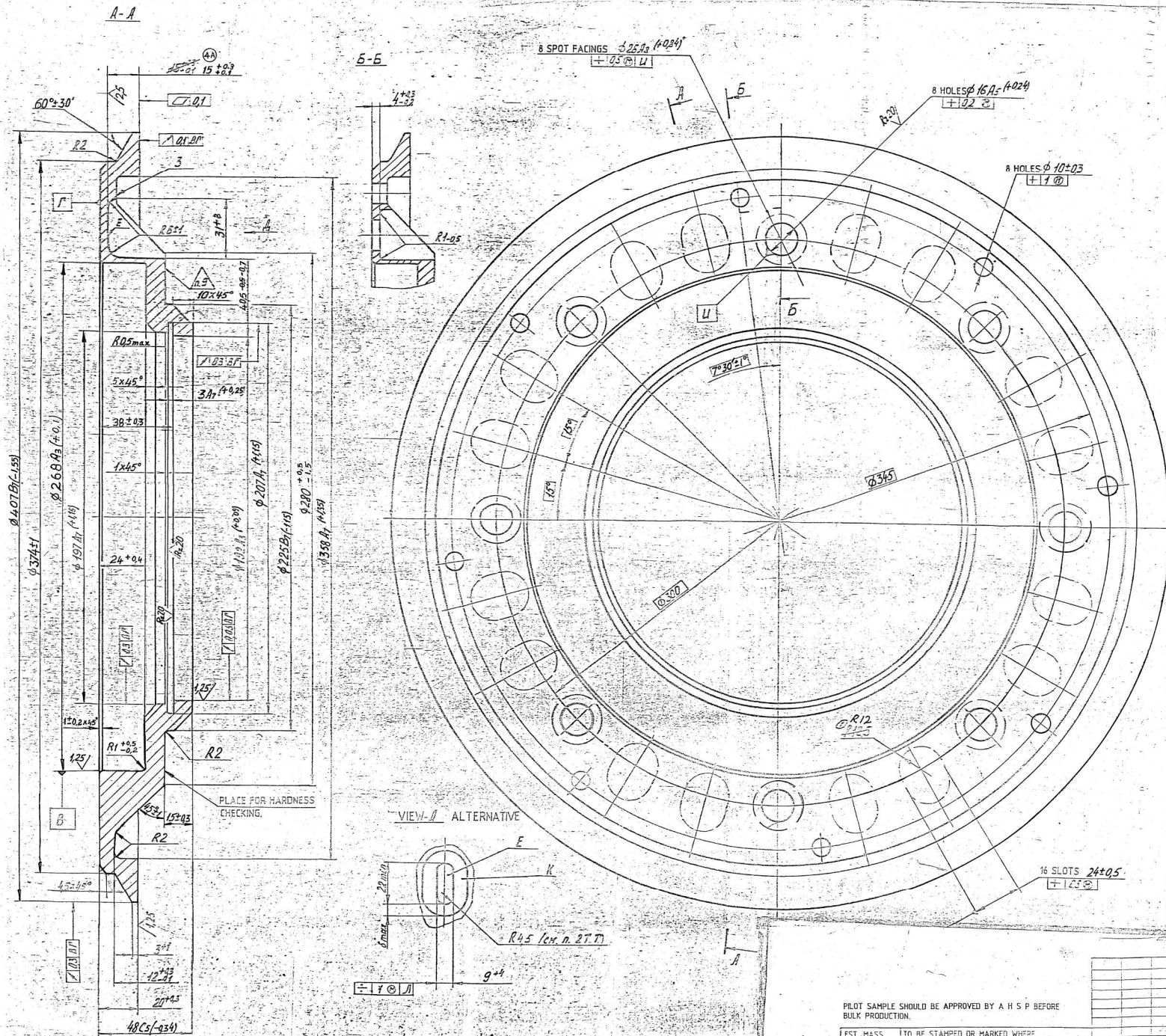

- BHN 353-302 (DIA OF INDENTATION 3.2-3.5)
- AT TRANSITION FROM SURFACE "E" TO SURFACE "K" OVER PROFILE OF ELLIPSE ALLOWED IS A SHOULDER OF A HEIGHT OF 1 mm MAXIMUM WITH A MERGING RADIUS OF APPROXIMATELY 3mm WITH TRANSITION ANGLE OF MINIMUM 45° RELATIVE TO SURFACE "K" IS ALLOWED ON SURFACE "K" ROUGHNESS OF Rz 80 IS PERMISSIBLE.
- WHILE MAKING RECESS, SURFACE FINISH OF 2.5 SHOULD BE PROVIDED OVER AN AREA AT LEAST 18.5 mm LONG AND 6.5 mm MINIMUM WIDE.
- SURFACE FINISH ACCURACY OF 1.25 OVER  $\phi 268$  A3 SHOULD BE PROVIDED AT A DISTANCE OF MINIMUM 22 mm FROM FACE "F" ON REMAINING LENGTH SURFACE FINISH OF 2.5 IS ALLOWED.
- THE COMPONENT SHOULD BE BALANCED ON OUT-OF-BALANCE WEIGHT IS MAXIMUM 5 GRAMMES OVER R 195 mm IS ALLOWED. WHILE BALANCING ALLOWED IS DRILLING OF HOLES  $\phi 10 \pm 1$  ON PLANE 3 IN THIS CASE THE WALL THICKNESS BETWEEN THE HOLES FOR BALANCING AND THE ADJACENT HOLE OF  $\phi 10$  mm MUST BE MINIMUM 5mm
- OUT OF THE GROUP OF 8 HOLES  $\phi 10 \pm 0.3$  TWO DIAMETERICALLY OPPOSITE HOLES M 10-7H ARE ALLOWED TO BE THREADED M 10-7H.
- COATING: CHEMICAL OXIDIZING OIL FINISHED OR CHEMICAL OXIDIZING OIL FINISHES ON SURFACES  $\phi 192$  AND  $\phi 268$  ABSENCE OF COATING IS ALLOWED. **OXIDO - PHOSPHATING**
- OTHER REQUIREMENTS AS PER 520 TY-1
- TO BE MARKED.
- ON 8 SPOT FACINGS  $\phi 26$  A8 INSTEAD OF RADIUS R1-0.5 CHAMFER  $1.25 \times 45^\circ$  IS ALLOWED.
- IN 16 SLOTS INSTEAD OF RADIUS R 6.21 CHAMFER OF  $3 \times 45^\circ$  IS ALLOWED.

COMMON TO BLT  
DRAWING PREPARED BASED ON ISSUE-4

F-76

PILOT SAMPLE SHOULD BE APPROVED BY A H S P BEFORE BULK PRODUCTION.

EST. MASS 9 Kg TO BE STAMPED OR MARKED WHERE INDICATED THIS IN LETTERS

ALL SHARP EDGES AND CORNERS TO BE REMOVED UNLESS OTHERWISE STATED MACHINED CORNERS TO HAVE R OUTSIDE R INSIDE EQUIVALENT CHAMFERS ARE PERMISSIBLE

DRW	DATE	MATERIAL	USED ON
ENG		STEEL 38 X C	172 40 018 Cb
TEC		GOST 4543-71	
APRD		CONTROL RATE OF QUALITY ASSURANCE HEAVY WEAPONS	A V A D I
DATE	7.9.88		
SCALE	1:1		
DIMENSIONS IN mm			
TOLERANCE ON DIMS UNLESS OTHERWISE STATED IN mm			
TITLE	BOOSTER		
ALL REQUIREMENTS OF GOST 10050			
ISSUE DATE	28-11-98 Russian Spits. Decision on 28-10-98		172 40 270
NATURE OF AMENDMENTS			

**RESTRICTED  
(DRAFT/PROVISIONAL)  
QUALITY ASSURANCE PLAN**

**FOR**

**(BOOSTER)**

**DRG.NO. 172.40.270**

**(LF NO: 6206401096)**

**No HVF/T-72/QAP/40/BOOSTER/243978 - 00**

**ISSUE No: 00**

**DATE: JUNE-2022**

**QUALITY ASSURANCE (RIG-(OE))**

**HEAVY VEHICLES FACTORY**

**AVADI CHENNAI – 600 054**

**QUALITY ASSURANCE PLAN (QAP)**

**FOR**

**BOOSTER**

**DRG. NO. 172.40.270**

PREPARED BY

  
( C.NANDA KUMAR )  
JWM/QA (RIG-OE)

REVIEWED BY

  
(AWNEESH YADAV)  
JWM/QA (RIG-OE / TA)

APPROVED BY

  
(NEERAJ KUMAR )  
DGM/QA-RIG-(OE)

ISSUED BY

QUALITY ASSURANCE (RIG-(OE))  
HEAVY VEHICLES FACTORY  
AVADI CHENNAI – 600 054

Sl. no	CONTENTS	PAGE .No.
1.	IMPORTANT NOTES	4
2.	INTRODUCTION	4
3.	AIM	4
4.	SCOPE	5
5.	DOCUMENTS	5
6.	ITEM USED ON	6
7.	LIST OF DRAWINGS	6
8.	BILL OF MATERIAL	6
9.	CONDITIONS OF USE/ STORAGE INSTRUCTIONS	6
10.	SAMPLING PLAN	7
11.	VISUAL INSPECTION	7
12.	DIMENSIONAL CHECKS	8
13.	MATERIAL CHECKS	8
14.	ACCEPTANCE / PERFORMANCE TESTS	9
15.	FITMENT AND PERFORMANCE TEST	9
16.	INTERCHANGEABILITY	10
17.	CALIBRATION CHECKS	10
18.	MARKING/IDENTIFICATION	10
19.	PRESERVATION CHECK	10
20.	PACKING CHECK	11
21.	DOCUMENTATION	11
22.	REFERENCE	11
23.	ANNEXURE-A	12
24.	FIGURE	13
25.	APPENDIX-A	14



## **1. IMPORTANT NOTES**

### **Note-1**

This is only a provisional and will be amended from time to time according to the requirement. No addition, deletion and reproduction will be done without permission of The Chief. General Manager, Heavy Vehicles Factory, Avadi, Chennai – 54.

### **Note –2**

Any instruction contained in this does not prejudice the terms and conditions of the contract what so ever. In case of any contradiction between the contents of this QAP and the clause in the contract, the latter will prevail.

### **Note-3**

The stores should be manufactured strictly only as per the drawings supplied by the Inspection Authority and not as per the samples, if any received by the manufacturer for guidance purpose.

### **Note-4**

Any amendment issued by the Inspection Authority shall be incorporated in the QAP and the records for the amendments carried out should be maintained as per the Performa at Appendix-“A”.

### **Note-5**

In case of any contradiction between the contents of this QAP and drawings/Specifications/GOST issued along with the contract, the latter only will prevail.

## **2. INTRODUCTION**

1. This quality plan lays down the inspection and testing procedure to be carried out on the component **BOOSTER TO DRG.NO 172.40.270** being procured indigenously. This is prepared, based on the acceptance standards and inspection parameters laid down in collaborators documents and on the inspection test standards followed in respect of similar indigenous items.
2. This QAP is the property of Government of India and is liable for amendments as and when required. The Chief. General Manager, Heavy Vehicles Factory, Avadi, Chennai – 600 054, is the inspecting Authority for this assembly. Any query / clarification on the content of this QAP shall be referred to this Factory. Any departure from these instructions is allowed only after written approval from the above authority. Notwithstanding the tests indicated in this QAP, the inspecting Officer has the right to carry out any test to check conformance to the paper particulars quoted in the Supply Order, which he may consider necessary to satisfy himself about the stores which he has to accept.

## **3. AIM**

The QAP is aimed at standardizing the Inspection procedure and acceptance norm for **BOOSTER TO DRG.NO:172.40.270**.

It also aims at giving adequate information to the manufacturer on the quality requirements so that the required quality control methods are established. This is also meant to guide authorized Inspection Officer in his routine inspection and to set out main points to which his attention must be drawn to ensure that the accepted stores meet the stipulated standards.

#### **4. SCOPE:**

This QAP outlines in general terms, the checks and methods to be used during inspection of **BOOSTER TO DRG. NO. 172.40.270** including the technical requirements of the drawings. The recommended Quality Plan stipulated herein is mandatory and should be strictly adhered to.

For inspection purpose, only the latest issue of this QAP will be made applicable and copies of this QAP can be obtained from the issuing authority i.e. The Chief. General Manager, Heavy Vehicles Factory, Avadi, and Chennai.

#### **NOTE-I:**

- i. Tender enquiry (TE) and supply order (S.O) will be issued with QAP stating that inspection will be done as per QAP.
- ii. In case of TE, It is responsibility of the vendor to obtain the copy of QAP and give the statement of compliance that vendor will abide by the QAP in case supply order is placed.
- iii. In case of S.O, it is the responsible of the vendor to obtained copy of QAP and give the statement of compliance that the vendor will follow QAP. However, GM/HVF reserves the right to revise/update the QAP from time to time.

#### **5. DOCUMENTS:**

- a) On placement of firm supply order, one set of relevant technical documents like GOST/drawing/specification, technical data book, process sheet etc and technical instructions on the subject item to be obtained by the contractor from AHSP through DDO/HVF
- b) Any clarification required on these documents to be obtained from the Inspecting Authority i.e. The Chief. General Manager, Heavy Vehicles Factory, Avadi, Chennai – 600 054. Equivalentents to the collaborators specifications and standards will be decided only by the Inspecting Authority and should not be unilaterally decided. For any change in the specifications, standards or written approval, any alterations in specification can be affected and not otherwise.
- c) The process instruction sheets supplied by the collaborators are available with the Authority Holding Sealed Particulars, i.e. The Controller ate of Quality Assurance (Heavy Vehicles), Avadi, Chennai for the reference. The relevant process sheets may be studied at the premises of the AHSP after obtaining necessary permission.
- d) The supplier after scrutiny of the concerned process sheets and connected paper particulars should establish the necessary production and inspection facilities. Particularly the inspection test rigs, stands, fixtures, template, gauges etc should be provided as recommended in these process sheets. If process

sheet / Process Book is not available the details particulars/parameters available in the drawings to be strictly adhered.

**6. ITEM USED ON:**

1. 172.40.018CB

**7. LIST OF DRAWINGS:**

SI. NO.	DRG. NO	NOMENCLATURE	REMARKS
1	172.40.270	BOOSTER	---

**8. BILL OF MATERIALS: (Individual items as mentioned in table to Para 7)**

SI. NO	DRG. NO	NOMENCLATURE	MATERIAL SPECIFICATIONS	Qty
1	172.40.270	BOOSTER	STEEL 38XC GOST:4543-71	1

**Note:** Vendor/Contractor may use approved alternate material, if any specified in drawing/specification.\* Also refer Para no: 13.

**9. CONDITIONS OF USE/STORAGE INSTRUCTIONS**

This assembly/item should be properly packed to protect from transit / handling damage and influence of atmospheric precipitations. In addition, the following parameters should be ensured:

- (a) The threaded parts if any should be covered with suitable plastic caps to prevent damages.
- (b) If the item consists of assemblies, each assembly should be packed separately.
- (c) The stores are to be suitably covered for preventing ingress of dust and Dirt/entry of sunlight / moisture.
- (d) The packaging slip shall contains
  - (i) Certificate of testing- NABL Certificate.
  - (ii) Guarantee/ Warranty Certificate
  - (iii) Service and maintenance instructions
  - (iv) Delivery Slip with Inspector's Acceptance Mark
  - (v) Undertaking letter / certificate of conformance (As applicable).
- (e) The stores are not permitted to be stored together with oils. Petrol, acids, alkaline and other substances to avoid damage to the metal / rubber components.

## 10. SAMPLING PLAN:

Sl. No.	Sampling Plan	Pilot	Bulk
<b>Acceptance test (As below)</b>			
(i)	Visual Inspection	100%	100%
(ii)	Dimensional Inspection (Including hardness)	100%	General Inspection level III, single sampling, Normal Inspection, AQL 2.5 of IS 2500 (Part-I)-2000
(iii)	Material Inspection (Including Mechanical, Chemical and Physical properties)	1 No	1 No. or qty as specified in specification, GOST for each batch of raw material or heat treatment lot / As required for confirmation of material.
(iv)	Pressure testing	-----	-----
(v)	Machining/Fitment/ Performance trial on higher assembly / Tank	01 No.	01 No. per batch/As required.
(vi)	Interchangeability Test	-----	-----
(vii)	Calibration reports/certificates of Test stand/Jigs/Equipment/ Fixtures/Gauges/Mandrels/etc.	100 %	100 %
(viii)	Marking/Identification	100%	100%
(ix)	Packing/ Preservation	100%	100%

### **Note:-**

A New (First time supplier of this item) supplier should obtain clearance from HVF for bulk production which will be issued only after inspection/evaluation of pilot samples by HVF.

### **11. VISUAL INSPECTION [Sampling plan as per Para- 10 (i)]**

The stores are to be visually examined on 100 % of pilot /bulk and same should be free from any defects and all the finishing requirements shall satisfy as indicated in technical conditions of the assembly / component drawing.

The components shall be checked for the following and should be free from the defects:

- Defects in construction
- Cracks/Dents/Scratches

- Fitment of all components
- Presence of foreign particles
- Moisture and dust
- Corrosion of metal parts
- Mechanical imperfections & distortion
- Any form of deterioration of material and finishing.

Packing and preservation should be ensured as per drawings/relevant TY specification (To be ensured on receipt at consignee end).

## 12. DIMENSIONAL CHECK [Sampling plan as per Para- 10(ii)]

The dimensions of individual component, sub assembly and major assembly shall be checked and ensured as per respective drawing. Dimensional check should be carried out as per sampling plan. However, the inspecting authority/rep. may at his discretion, tighten the inspection level and acceptance quality level on the critical items and adopt check point during manufacture.

### 12.1 BOOSTER TO DRG.NO 172.40.270

1. All dimensions shall be confirmed as per drawing/specification
2. Place for checking the hardness refer drawing
3. Surface finish/Roughness should be confirmed as per drawing and specification.
4. For admissible alternate method for manufacture in dimensions/material if any, refer drawing/specification.

## 13) MATERIAL CHECKS [SAMPLING PLAN AS PARA – 10 (iii)]

Material specimen /test bars of the components shall be in conformity as per the material mentioned in the relevant documents/drawing. NABL test reports for all the parameters as per relevant specifications to be submitted. Test samples to be submitted by the vendor to HVF, if required. The material check will be carried out as per sampling plan.\* However, if the manufacturer proposes any alternative material at the stage of tender enquiry, the same has to be approved and a written concurrence should be obtained from AHSP through DDO/HVF, before usage of such materials.

### 13.1 BOOSTER TO DRG.NO.172.40.270

- a) The component should be manufactured from STEEL 38XC GOST 4543-71
- b) **Chemical properties:** As per STEEL 38XC GOST 4543-71.

Grade	CONTENT OF ELEMENTS%							
	C	Si	Mn	Cr	S	P	Cu	Ni
					MAX			
38XC	0.34 to 0.42	1.00 to 1.40	0.30 to 0.60	1.30 to 1.60	0.035	0.035	0.30	0.30

**Note:** For mass fraction of other elements refer GOST 4543-71.

- c) **Mechanical properties:** As per STEEL 38XC GOST 4543-71.

Grade	Yield point, (kgf/mm <sup>2</sup> )	Ultimate strength, (Kgf/mm <sup>2</sup> )	Elongation %	Relative reduction of area %	Impact strength (Kgm/cm <sup>2</sup> )
	Not less than				
38XC	75	95	12	50	7

Note: For other parameters refer GOST 4543-71.

#### 14) PERFORMANCES / ACCEPTANCE TEST: BOOSTER TO DRG.NO:172.40.270

1. BHN 363-302 ( DIA OF INDENTATION 3.2-3.5 )
2. AT TRANSITION FROM SURFACE "E" TO SURFACE "K" OVER PROFILE OF ELLIPSE ALLOWED IS A SHOULDER OF A HEIGHT OF 1 mm MAXIMUM WITH A MERGING RADIUS OF APPROXIMATELY 3mm WITH TRANSITION ANGLE OF MINIMUM 45° RELATIVE TO SURFACE "K" IS ALLOWED ON SURFACE "K" ROUGHNESS OF Rz 80 IS PERMISSIBLE.
3. WHILE MAKING RECESS SURFACE FINISH OF 2.5 SHOULD BE PROVIDED OVER AN AREA AT LEAST 18.5 mm LONG AND 6.5 mm MINIMUM WIDE.
4. SURFACE FINISH ACCURACY OF 1.25 OVER  $\phi 268$  A3 SHOULD BE PROVIDED AT A DISTANCE OF MINIMUM 22 mm FROM FACE C ON REMAINING LENGTH SURFACE FINISH OF 2.5 IS ALLOWED.
5. THE COMPONENT SHOULD BE BALANCED ON OUT OF BALANCE WEIGHT IS MAXIMUM 5 GRAMMES OVER R 195 mm IS ALLOWED . WHILE BALANCING ALLOWED IS DRILLING OF HOLES  $\phi 10 \pm 1$  ON PLANE 3 IN THIS CASE THE WALL THICKNESS BETWEEN THE HOLES FOR BALANCING AND THE ADJUCENT HOLE OF  $\phi 10$  mm MUST BE MINIMUM 5mm.
6. OUT OF THE GROUP OF 8 HOLES  $\phi 10 \pm 0.3$  TWO DIAMETERICALLY OPPOSITE HOLES M 10-7H ARE ALLOWED TO BE THREADED M 10-7H.
7. COATING : CHEMICAL ~~OXIDIZING / PHOSPHATING~~ <sup>OXIDO - PHOSPHATING</sup> OIL FINISHED OR CHEMICAL OXIDIZING OIL FINISHED ON SURFACES  $\phi 192$  AND  $\phi 268$  ABSENCE OF COATING IS ALLOWED.
8. OTHER REQUIREMENTS AS PER 520 TY-1.
9. TO BE MARKED.
10. ON 8 SPOT FACINGS  $\phi 26$  A8 INSTEAD OF RADIUS R1<sup>-0.5</sup> CHAMFER 1<sup>-0.5</sup> X 45° IS ALLOWED.
11. IN 16 SLOTS INSTEAD OF RADIUS R  $6 \pm 1$  CHAMFER OF 3 X 45° IS ALLOWED.

#### 15) FITMENT AND PERFORMANCE TEST:

- a. Pilot samples should be checked for fitment and Performance test to ascertain the efficacy of the system under different operating conditions by fitting in higher assembly and repeating it for functional checks, wherever required.
- b. Items of Bulk supplies may be subjected to performance trial in tank in case of repeated failure/defects during exploitation.

**EXPLANATORY NOTE:**

- 1) Stage wise process and inspection of the component as specified in TD Book/ Process Book/ illustration book/specification is to be confirmed by the supplier during manufacturing the components.(Refer QAP Para no: 5(a)).
- 2) Firm shall submit details of manufacturing process, inspection process and also reports for the same to HVF.
- 3) If required/applicable HVF shall witness/verify stage wise inspection /process details during manufacturing of the components.
- 4) The component may be subject to endurance test, when fitted in higher assembly as specified in process / illustration /TD book.
- 5) Apart from above, all other relevant test for acceptance of the item as specified in GOST / Specification / drawing shall be carried out by the firm and the report/ certificates shall be submitted to HVF.

**16) INTERCHANGEABILITY:**

The assemblies/component should be interchangeable component wise and assembly wise, except the Component are to be supplied as a set and to be assembled selectively as per sampling plan.

**17) CALIBRATION CHECKS**

**(TEST STANDS/JIGS/FIXTURES/GAUGES/INSTRUMENTS):**

The supplier / Contractor should have suitable Instruments, Test Stand, jigs, fixture, mandrels and gauges to carry out quality checks, to ensure conformance of components/assembly as per drawing and Specification /T.R points.

The supplier/contractor should submit calibration reports for instruments/fixtures/gauges/mandrels etc., which are used during process of inspection activities.

**18) MARKING/IDENTIFICATION**

Marking of the items is to be carried out as called for in the relevant drawing, drawing/T.R points.

Inscription if any on the components is to be carried out as called for in the drawing/T.R points. Unless otherwise specified in the drawing/ specification, marking should not be carried out over the components.

For traceability, marking of part No., Manufacturer name, supply order No, Serial No/Qty, batch No. and manufacture date & year are to be carried out. Suitable method can be adopted, provided that the above parameters are legible and considering the parameters mentioned in the drawing and specification. (Refer QAP Para no: 14(9)).

**19) PRESERVATION CHECK**

- a) Preservative coatings are to be strictly adhered to as called for in the drawing. However, equivalent BIS Standards can also be followed, subject

to the thickness of the coating/preservative is maintained as per the drawing/specification.

- b) Other preservations as necessary to prevent damages due to moisture and dust during process, storage and transit are to be carried out. Conventional Methods can also be resorted to.

## 20) PACKING CHECK

Components / Assemblies are to be packed separately to avoid damages during transit / handling of the same. Part No. and No. of sets are to be marked on the packing.

Packing and preservation should be ensured as per drawings/relevant TY specification (To be ensured on receipt at consignee end).

Finished products shall be wrapped / packed using black and opaque polyethylene sheet or bags.

## 21) DOCUMENTATION

- i. Firm has to maintain all the documents as per QAP with respect to the SI.No.to have traceability.
- ii. Vendor has to submit Bill of materials, Material test reports, Class 'C' /Endurance test reports (wherever specified in drawing/TY specification/QAP) and Complete PIR (pre-inspection report)at the time of offering the item for inspection. HVF will commence inspection only after scrutiny of these documents.
- iii. The testing/inspection responsibility to test all the parameters as per QAP and drawing specifications as mentioned in Annexure -A (enclosed).
- iv. Pre inspection reports (PIR) of firm like, 1. Chemical analysis (NABL Certificate), 2.Mechanical properties (NABL Certificate), 3. Pre-forming process, 4. Coating certification. 5. Calibration reports of instruments and 6. 100 % Dimensional inspection reports and other relevant reports for acceptance of the item as specified in GOST/ Specification / drawings etc.

## 22) REFERENCE:

1. Drawing No: 172.40.270.
2. Material specification as per drawing:  
STEEL 38XC GOST 4543-71
3. GOST 4543-71.
4. Specification: 520 TY 1.



SL. NO.	CATEGORY	ASSEMBLY/SUB ASSEMBLY	TESTS/INSPECTION PARAMETERS	STANDARDS TO BE REFERRED	ACCEPTANCE CRITERIA	INSPECTION RESPONSIBILITY			REMARKS
						Firm	HVF	DGQA	
1	BOOSTER TO DRG. NO 172.40.270	Pre inspection reports (PIR) of firm	Firm has to produced all the document as per Para 21 (iv)	As per the relevant drawing and QAP.	Confirm to drawing and QAP as per bill of material	P	V	R	100% by firm/ vendor.
2		Bill of material (BOM)	Firm has to prepare the BOM as per QAP	Refer QAP Para no: 8 or item list.	Confirm to QAP para no 8	P	V	R	100% by firm/ vendor.
3		Dimensional checks	Dimensions as per the drawing	Refer drawing /QAP Para no: 12.1	Confirm to drawing and QAP para no 12.1	P	W/P	R	100% by firm/ vendor SP followed by HVF.
4		Material tests	Chemical composition & Mechanical / Physical Properties	As per- GOST 4543-71	All the values to confirm with QAP Para no:13.1 (a), (b),(c)	P	W/V	R	SP followed by HVF.
5		Hardness check	Hardness BHN 363 – 302 (Dia of INDN 3.2 – 3.5)	Refer QAP Para no: 14(1)	Confirm to QAP Para no: 14(1)	P	W/V	R	100% by firm/ vendor SP followed by HVF.
6		Coating checks	Coating	Refer drawing /QAP Para no: 14(7)	Confirm to QAP Para no: 14(7)	P	W/P	R	100% by firm/ vendor SP followed by HVF.
7		Marking / traceability	Firm has to make marking / traceability records.	Refer QAP Para no: 18 &14(9)	Confirm to QAP Para no: 18 & 14(9)	P	V	R	100% by firm/ vendor.
8		Preservation & packing	Firm has to make Preservation & packing records	Refer QAP Para no: 19 & 20	Confirm to QAP Para no: 19 & 20	P	V	R	100% by firm/ vendor.

**Note:**

For conformity of the items (Chemical/Physical/Mechanical properties).

- One sample per heat / batch shall be tested under NABL Lab/Govt. Approved lab by firm. In case of non-compliance to standards entire lot shall be rejected or not to use in production further.
- For cross conformation of material, manufacturer has to submit test sample pieces for the items used / test slab and button for rubber items / HVF will draw samples from supplied lot for Witnessing (W) at HVF premises. In case of non-compliance to standards entire lot will be rejected.
- All other relevant tests as specified in GOST/ Specification / Drawing is to be carried out by firm and to be confirmed

P.- Perform

W- Witness

V-Verify

R-Review

SP-Sampling Plan

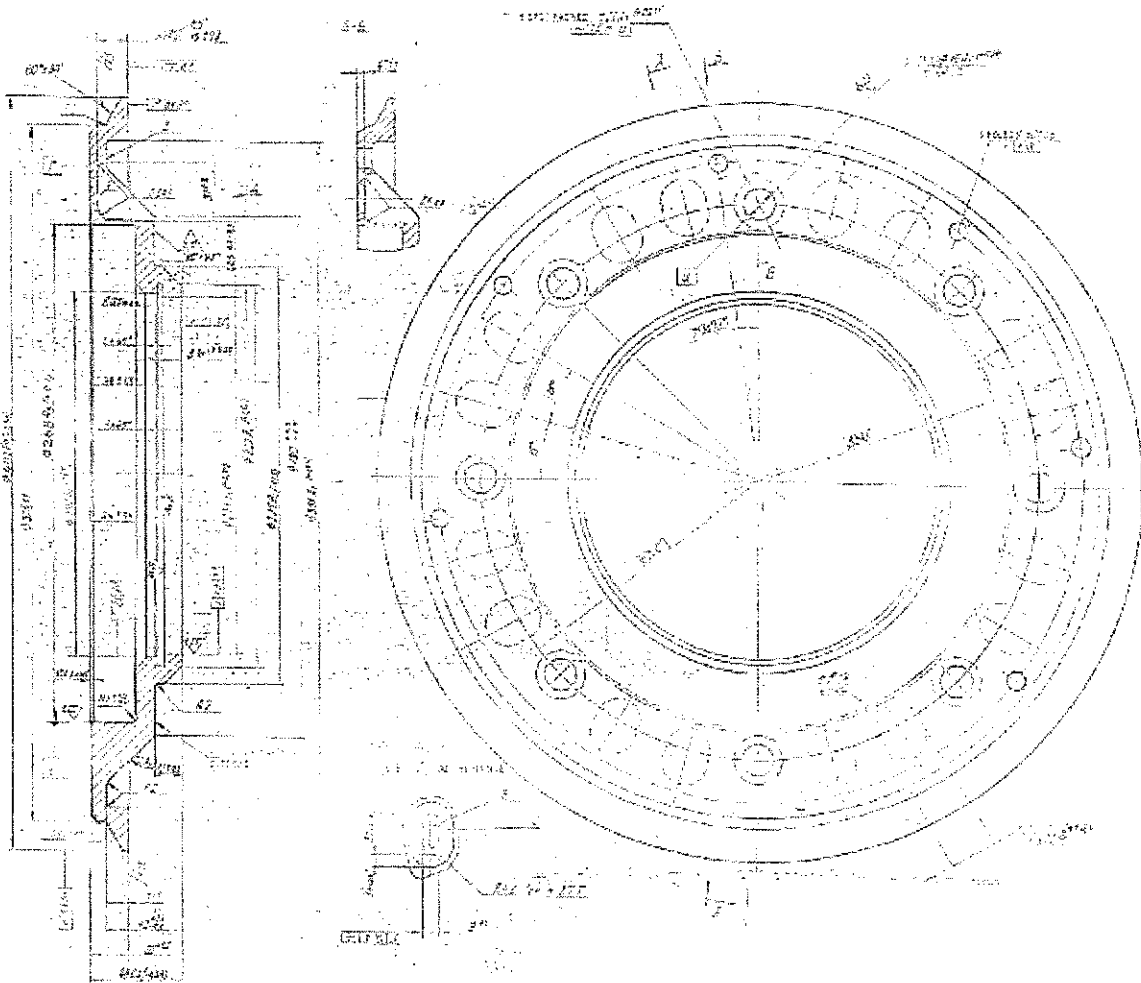

**FIGURE: BOOSTER TO DRG. NO 172.40.270**  
**(For Reference Only)**

RECORD OF AMENDMENTS

<b>Sl. No</b>	<b>Amendment No. &amp; date</b>	<b>Amended by</b>	<b>Date of Insertion</b>	<b>Initial</b>