

DRG. INDIANISED BASED ON RUSSIAN ORIGINAL ISSUE - NIL  
COMMON TO T-72 & BLT.

DRAWING NUMBER  
**520.01.005**

SHEET No. 1 OF 1

Rz80/√

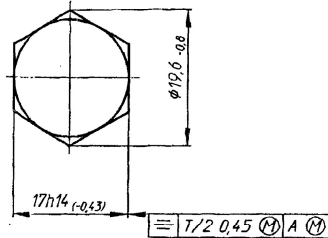
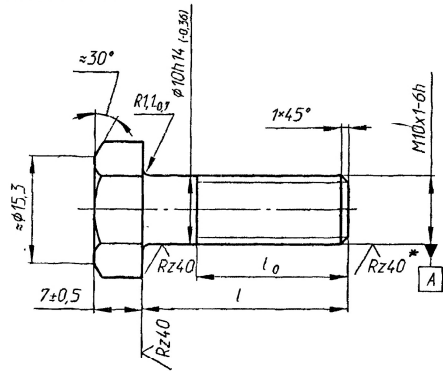

Вариант  
ALTERNATIVE

Вариант  
маркировки  
ALTERNATIVE  
FOR MARKING

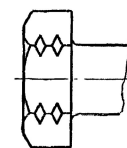
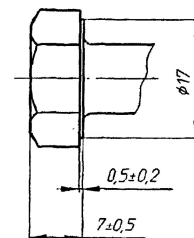

1. Alternate material: Steel 40 GOST 1050-88 and Steel 20nc GOST 10702-78.
- ① 2. Bolts 520.01.005-04, 520.01.005-08, 520.01.005-11 to be heat treated by BHN 255...302. Isothermal hardening BHN 311... 415 is allowed.
- 3 Bolt head may be made as per GOST 7798-70.
4. When making thread by rolling, unthreaded part of rod may be made along the pitch diameter of thread and chamfer at the end of rod is not to be made.
- ① 5. — Mark the material of bolts 520.01.005-04, 520.01.005-08, 520.01.005-11, 520.01.005-12 by letter X on the face of head with type П0-5 GOST 2930-62.
6. Coating Zn 6 Chromotizing.
7. \* Surface finish is to be ensured by tool.
8. Other requirements should be as per GOST 1759.0-87 and 520.TY1.

① 188.31.124 Cb Cb \*\*  
PV572.0711.0081  
PV572.0711.0051  
① PV572.0718.0058  
PV572.0718.0163

① \*\* EQLT.MATL: Grade:070M20 to BS:970/83, Pt-I.

DESIGNATION Обозначение	l MM		l <sub>0</sub> MM		MATERIAL Материал	WEIGHT Масса, Кг/кг
	НОМИН. NOMINAL	пред. откл. LIMIT DEVIATION	НОМИН. NOMINAL	пред. откл. LIMIT DEVIATION		
520.01.005	16		16		STEEL GOST Сталь 20 ГОСТ 1050-88	0,023
-01	20		20		Сталь 20 ГОСТ 1050-88**	0,025
-02	22		22		STEEL GOST Сталь 20 ГОСТ 1050-88	0,026
-03	25		25		STEEL GOST Сталь 20 ГОСТ 1050-88	0,028
-04	25		25		STEEL GOST Сталь 38Х ГОСТ 4543-71	0,028
-05	30	+0,8	30		STEEL GOST Сталь 20 ГОСТ 1050-88	0,031
-06	35		26	+2,5	STEEL GOST Сталь 20 ГОСТ 1050-88	0,034
-07	55	+1,0	26	+2,5	STEEL GOST Сталь 20 ГОСТ 1050-88	0,046
-08	30		30		STEEL GOST Сталь 38Х ГОСТ 4543-71	0,031
-09	40		26	+2,5	STEEL GOST Сталь 20 ГОСТ 1050-88	0,035
-10	45	+0,8	26	+2,5	STEEL GOST Сталь 20 ГОСТ 1050-88	0,040
-11	35		26		STEEL GOST Сталь 38Х ГОСТ 4543-71	0,034
① -12	65		26		STEEL 38Х GOST 4543-71	0,052

PILOT SAMPLE SHOULD BE APPROVED BY A H S P  
BEFORE BULK PRODUCTION.

EST. WT. (kg) TO BE STAMPED OR MARKED WHERE  
SEE TABLE INDICATED THUS # ( LETTERS)

ALL SHARP EDGES AND CORNERS TO BE REMOVED UNLESS  
OTHERWISE STATED MACHINED CORNERS TO HAVE R OUT-  
SIDE R INSIDE EQUIVALENT CHAMFERS ARE PERMISSIBLE.

DRN	CHD	APPD	DATE	MATERIAL:-	USED ON:-
			17-02-04	SEE TABLE	№
SCALE:-				CONTROLLERATE OF QUALITY ASSURANCE (HEAVY VEHICLES) AVADI	
DIMENSIONS IN mm				TITLE:-	
TOLERANCE ON DIMS UNLESS OTHERWISE STATED IS: 2102-69				BOLT	
ALL THREADS TO CONFORM TO				D S CAT NUMBER	DRAWING NUMBER
ISSUE DATE NATURE OF AMENDMENTS					520.01.005

356

SUPPLY CODE  
U-01-1-1  
D90033

F-33  
5

SIZE A4x3