

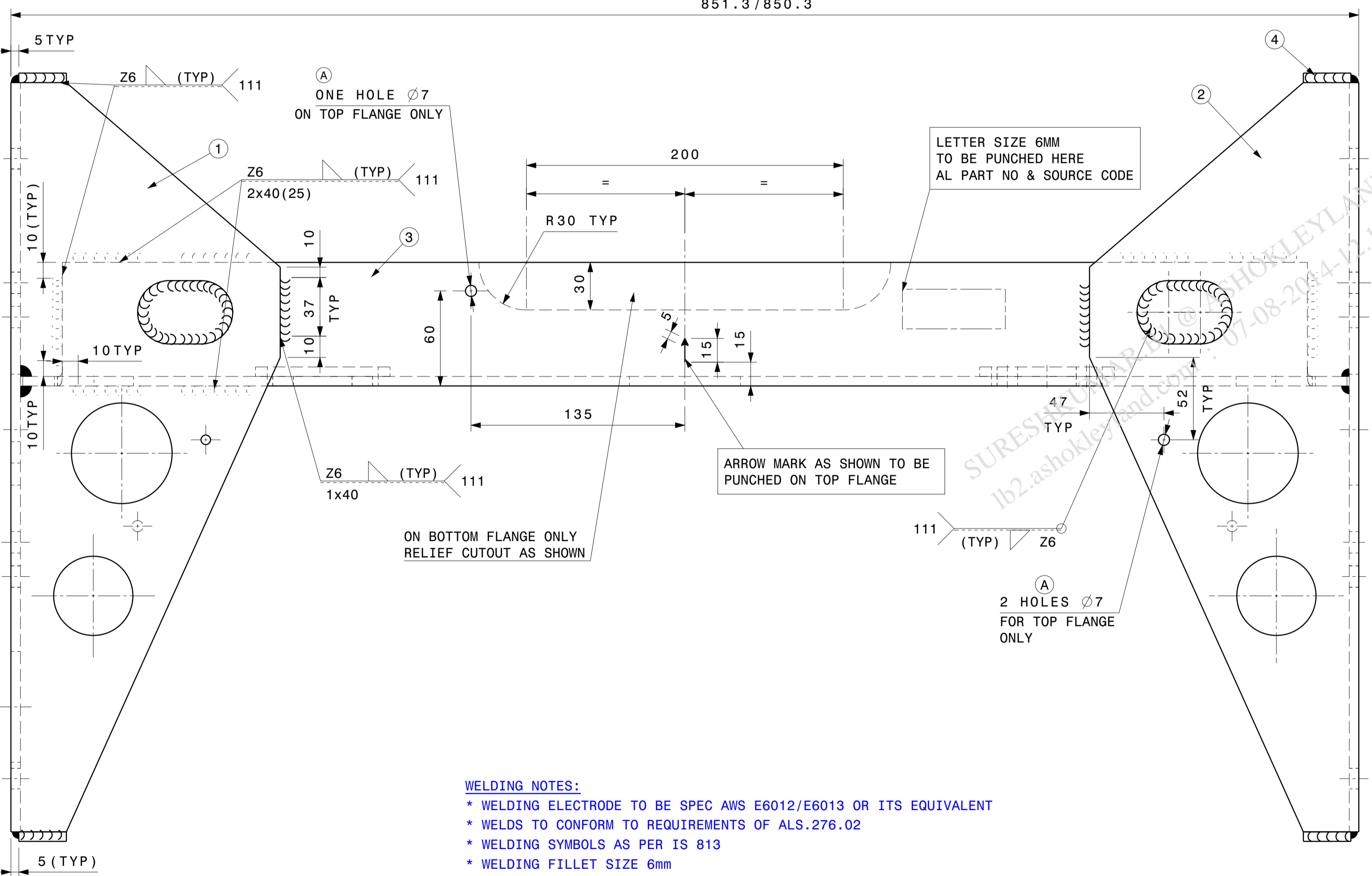

This design is strictly private and confidential. It is the exclusive property of Ashok Leyland Ltd., and must not be used, copied or reproduced in part or whole without the company's written permission.

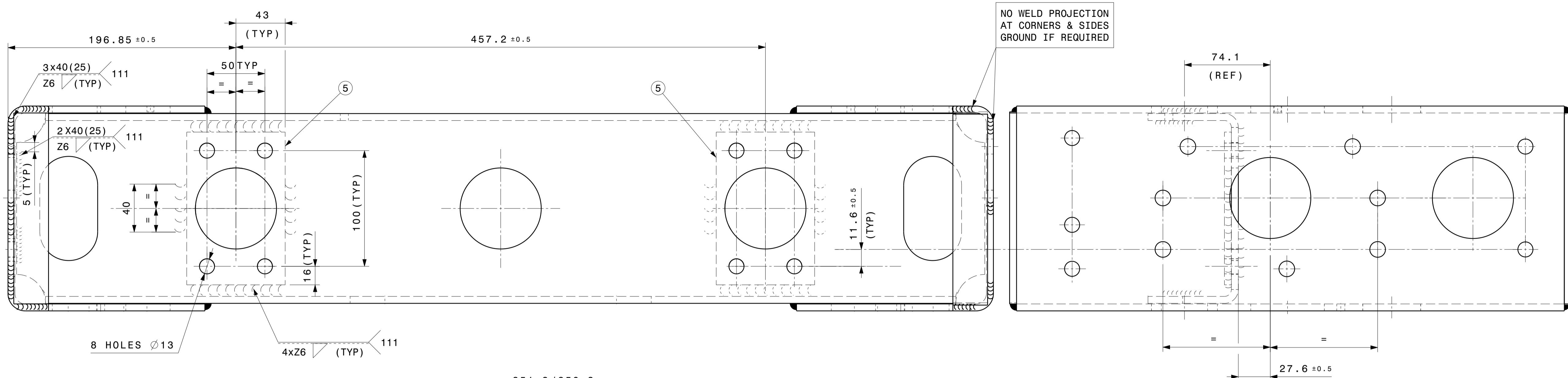

WELDING NOTES:

- * WELDING ELECTRODE TO BE SPEC AWS E6012/E6013 OR ITS EQUIVALENT
- * WELDS TO CONFORM TO REQUIREMENTS OF ALS.276.02
- * WELDING SYMBOLS AS PER IS 813
- * WELDING FILLET SIZE 6mm

PAINTING NOTES:

- (B) TO BE PAINTED WITH ENAMEL SCAMIC GREEN CONFORM TO (REF DRG NO: X9745000)
- (E)(D) * TO MEET CLASS 'C' AS PER ALS 268.03

COLOR: SCAMIC GREEN; SHADE NO.294 AS PER IS:5

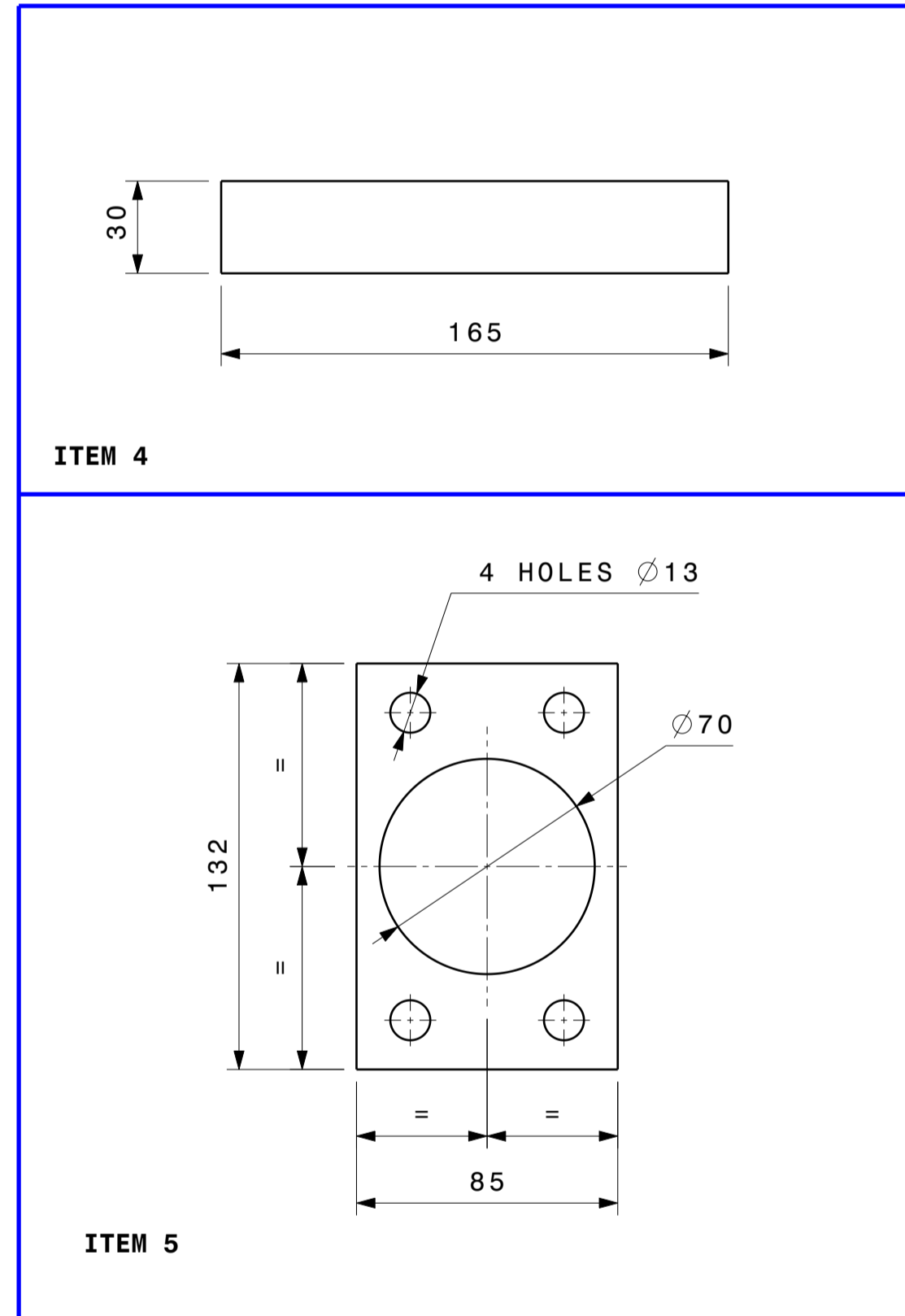

ALTERATIONS	DR. DATE	STATUS	REVISION
THREE HOLES Ø7 ADDED	21/09/02	-	A
PAINTING DETAILS UPDATED DIN:023048	ABM 07/03/05	-	B
DRG TEMPLATE UPDATED	JNR/SN 10/12/10	-	B.1
FOR STAGE III RELEASE	JNR/SN 10/12/10	-	B.2
PAINT NOTE UPDATED	VEE/BSV 29/04/11	-	C
CAD DRG UPDATED FOR PLM ERROR	SASI/AJS ERDIN 17894	-	D
DRG UPDATED FOR END GUSSETS THRU HOLE Ø50 WAS 63.5. SURFACE PROTECTION UPDATED.	KV/BSV 15/04/14	-	E

AL PLM VAULT

REVISION : E DATE : 6/5/2014 STATUS : RELEASE

STAGE : III ER-DIN NO : ER-DIN-002882 DATE : 6/5/2014

ALTERED BY : sundaralvc CHECKED BY : sureshkumar.b1

MED APPROVAL : sunilrajs APPROVED BY : sunagarajan.alvc

SL.No	PART NO.	DESCRIPTION	MATERIAL	QTY
5	ITEM05	SUPPORT PLATE	6 THK IS 2062 E250 Gr 'A'	2
4	ITEM04	END PLATE	6 THK IS 2062 E250 Gr 'A'	4
3	X4675414	X MEMBER	REF DRG	1
2	X4632114	GUSSET RH	REF DRG	1
1	X4632014	GUSSET LH	REF DRG	1

DRWN/ DATE	CHECKED/ DATE	MED APPROVAL/ DATE	APPROVED/ DATE	STDS APP/ DATE
MBC 20/03/02	ABM 29/04/02	CS 11/08/03	SN 29/04/02	

MATERIAL

HEAT TREATMENT

REMARKS

STALLION 4x4 MARK IV

DESCRIPTION

CROSS MEMBER - AGB FRONT

PART No. **B 8 1 3 6 5 0 2 E**

SHEET NO.1.....OF.....1..... **A1**

BILL OF MATERIALS			
APPEARANCE ITEM	ER-DIN	DATE	
YES	NO	ER-DIN-021183	25/02/05
FINISHED WEIGHT (APPROX)	REF. PT. No.	B1080502	
SCALE	S/A PT No.	A8136500	
1:2	SUPERSEDES		
	SPEC NO.	HAF147	

ASHOK LEYLAND LTD. TECHNICAL CENTRE, VELLIVOLCHAVADI

Q - IMPORTANT	Q - CRITICAL	Q - SAFETY.	THIS DRG. CONTAINS SAFETY CHARACTERISTIC
UNLESS OTHERWISE SPECIFIED			
ASHOK	TOLERANCES	REFER IS:2102 : MEDIUM FOR MACHINING AND COARSE FOR FABRICATION	
LEYLAND	SURFACE PROTECTION	FABRICATED COMPONENTS TO BE DEGREASED, DESCALED. APPLY ZINC PHOSPHATE, APPLY EPOXY PRIMER AND APPLY BLACK ENAMEL TO MEET 900 HRS OF SALT SPRAY LIFE WHEN TESTED AS PER ASTM D117 UNDER RELUCTANT CORROSION. NO BLISTERING IS ALLOWED. MACHINED SURFACE TO BE APPLIED WITH RUST PREVENTIVE OIL TO IS-1154	
	SURFACE FINISH AS PER IS:3073 (CLA VALUE)	METRIC BOREN THREADS SHALL CONFORM TO THE LIMITS AND TOLERANCES SPECIFIED IN THE CURRENT IS-4210	SHARP EDGES TO BE REMOVED DIMENSIONS ARE IN MM DO NOT SCALE DRAWING

SPECIAL INSTRUCTIONS/NOTE: