

22

1 LSS 0 0 0 0 2 V 0 0 3 VV 0 0 4 S 8 0 5 SS 1 0 6 CI 4 0 8 1 DRG No. DRG

GENERAL TOL. : FINE / MEDIUM / COARSE DRG. CONVENTIONS CONFIRM TO INDIAN STANDARDS CLASS TO IS: 2102 DIMENSIONS ARE IN mm UNLESS OTHERWISE STATED.

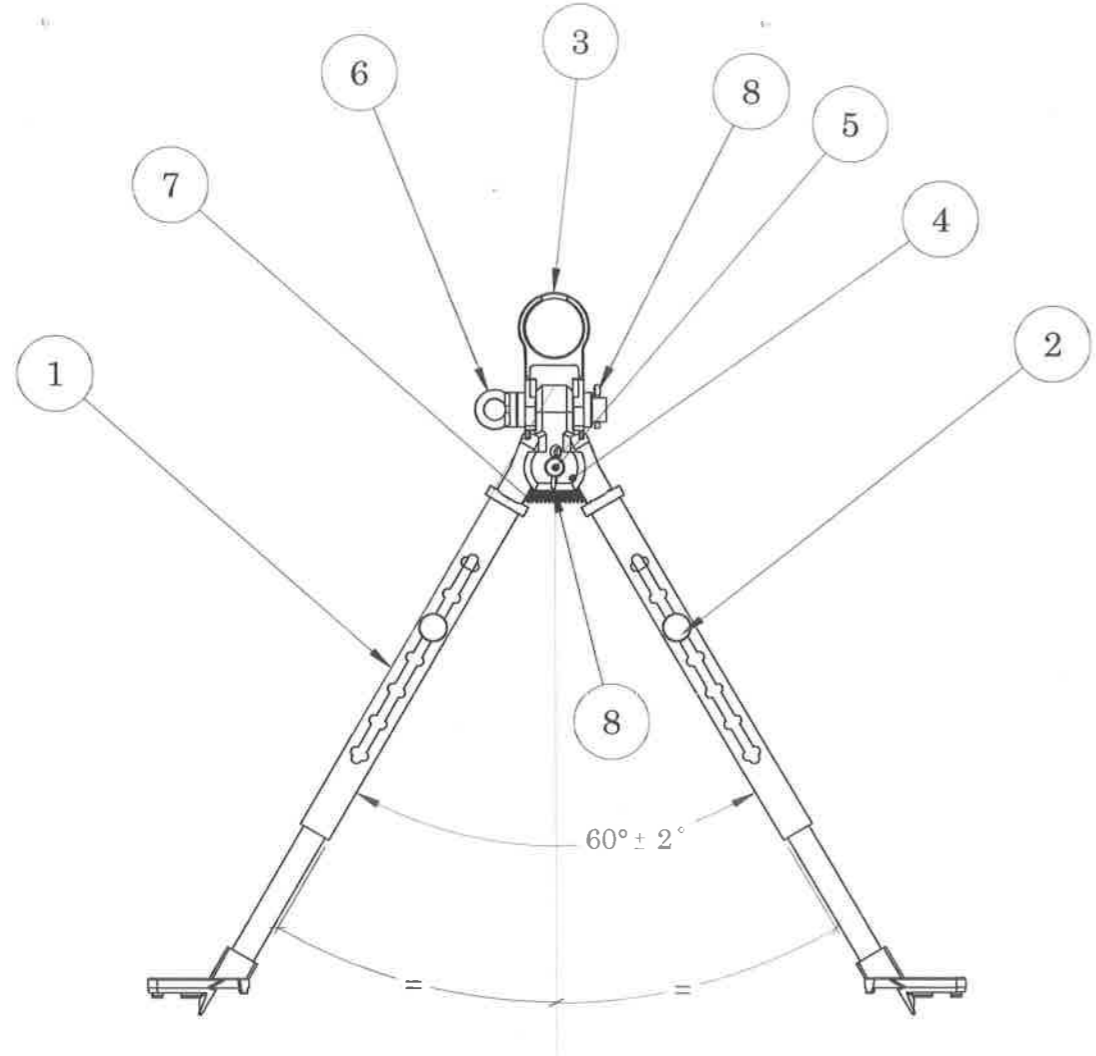

ITEM NO.	PART NUMBER	DESCRIPTION	QTY.	
1		LEG LEFT BIPOD ASSEMBLY	1804 01 08 01 00 000 00DA	1
2		LEG RIGHT BIPOD ASSEMBLY	1804 01 08 02 00 000 00DA	1
3		HOUSING SLEEVE BIPOD	1804 01 08 00 00 001 00DA	1
4		SLEEVE BIPOD	1804 01 08 00 00 002 00DA	1
5		PIN TORSION BIPOD	1804 01 08 00 00 003 00DA	1
6		SCREW AXIS BIPOD	1804 01 08 00 00 004 00DA	1
7		SPRING BIPOD	1804 01 08 00 00 005 00DA	1
8		COTTER PIN	STANDARD COMPONENT	2

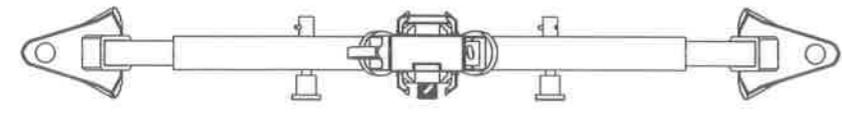
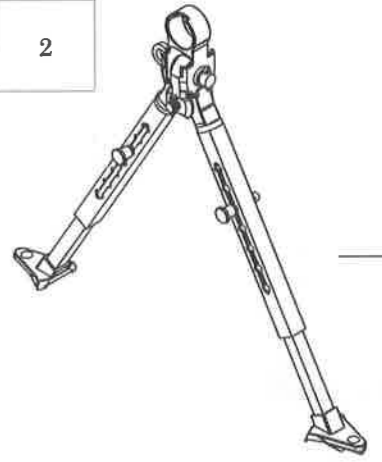

Sr. No.	DATE	AUTHORITY	BRIEF RECORD	ZONE	CD	GO
			MATERIAL:			
			PROTECTIVE FINISH:			
			TITLE:			
			BIPOD ASSEMBLY			
DRG No.	1 8 0 4	0 1	0 8	0 0	0 0	0 0 0 0 0 0 D A
	IC	SS	S	AA	A	C SST
LMG	PART No.	DS CAT No.		AHSP		

1 2 3 4 5 6 7 8

225

LSS C V VV S SS IC DRG No. 1 8 0 4 0 1 0 8 0 1 0 0 0 0 0 0 D A

GENERAL TOL. : FINE / MEDIUM / COARSE ✓ DRG. CONVENTIONS CONFIRM TO INDIAN STANDARDS CLASS TO IS: 2102 DIMENSIONS ARE IN mm UNLESS OTHERWISE STATED.

ITEM NO.	PART NUMBER	DESCRIPTION	QTY.
1		LOWER LEG LEFT AND FOOT BIPOD WELDING ASSEMBLY	1
2		UPPER LEG BIPOD AND LATCH BIPOD WELDING ASSEMBLY (LEFT)	1
3		PLUNGER BIPOD	1
4		SPRING INNER BIPOD	1
5		WASHER BIPOD	1
6		DOWEL PIN (φ 1.5 x 8.0)	1

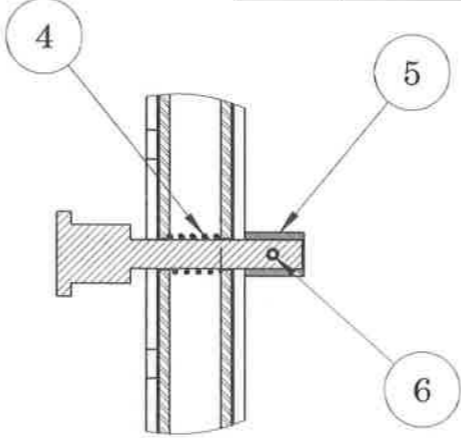
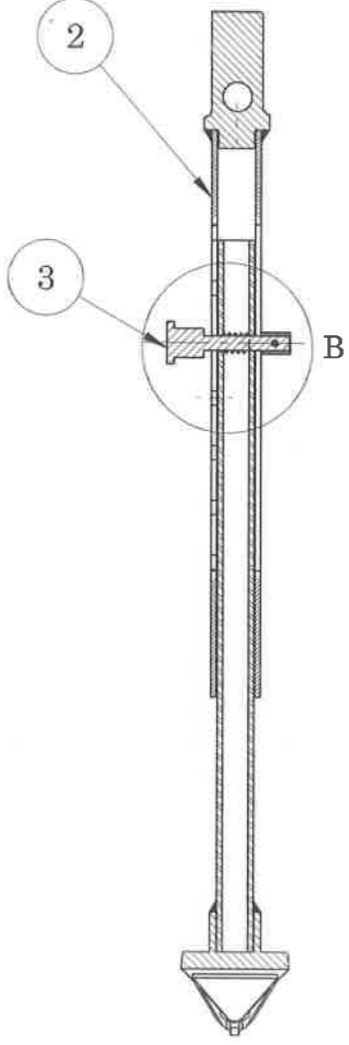
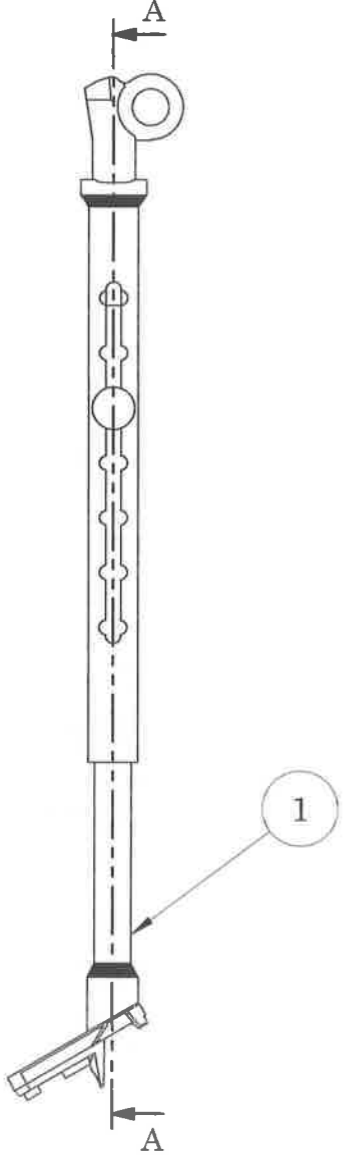

DETAIL B
SCALE 1:1

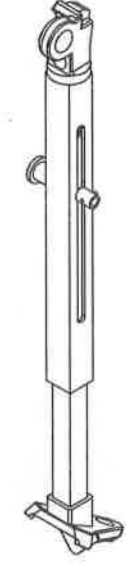

SECTION A-A

Sr. No.	DATE	AUTHORITY	BRIEF RECORD	ZONE	CD	GO
DRN: HARSH			MATERIAL:			
SIGN:			-----			
DATE: 04/09/2020		CHECKED				
APPD.			PROTECTIVE FINISH:			
DATE: 04/09/2020		FOR DIRECTOR	-----			
SEALED						
DATE:						
SHEET SIZE: A3	EST. MASS		TITLE:			
SCALE: 1:2	approx. 250 gm		LEG LEFT BIPOD ASSEMBLY			
DESIGN AUTHORITY						
ARDE						
PUNE 411021						
DRG No.	1 8 0 4	0 1	0 8	0 1	0 0	0 0 0 0 0 0 D A
	IC	SS	S	AA	A	C SST
LMG	PART No.		DS CAT No.			AHSP

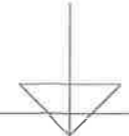

227

LSS V D 0 0 O I 0 0 V I 0 VV I 0 S 8 0 SS I 0 OI 4 0 8 1 DRG No. DRG

NOTE
REMOVE ALL SHARP EDGES AND BURR.

GENERAL TOL. : FINE / MEDIUM / COARSE DRG. CONVENTIONS CONFIRM TO INDIAN STANDARDS CLASS TO IS: 2102 DIMENSIONS ARE IN mm UNLESS OTHERWISE STATED.

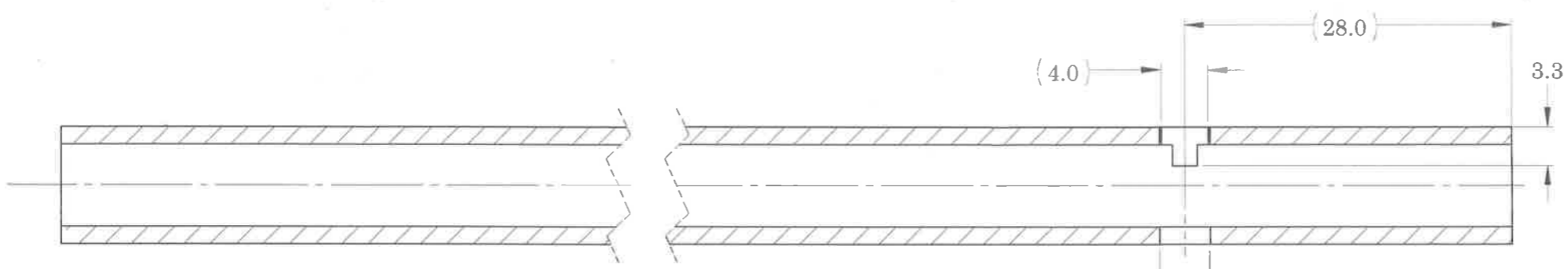

SECTION A-A

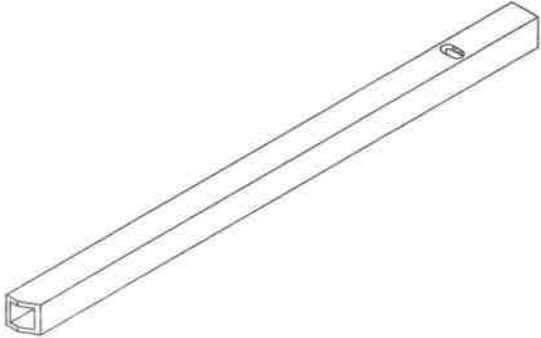
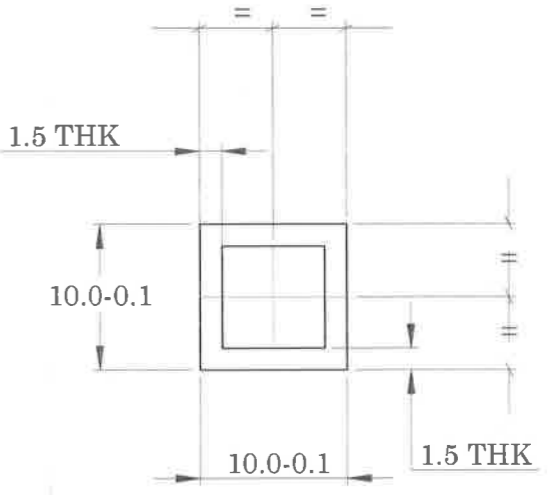
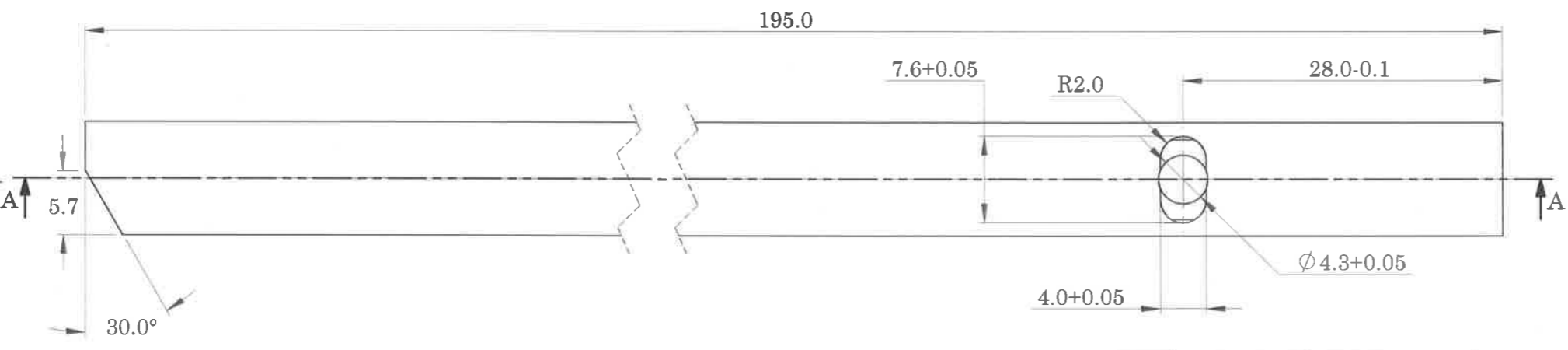

Sr. No.	DATE	AUTHORITY	BRIEF RECORD	ZONE	CD	GO
DRN: HARSH SIGN: DATE: 04/09/2020			MATERIAL: IS 4923:1997 Yst 310			
APPD. DATE: 04/09/2020			PROTECTIVE FINISH: NIRIDING DULL BLACK MATT FINISH AS PER MIL-S-6090 A COATING THICKNESS : 10-20 MICRONS			
SEALD DATE: SHEET SIZE: A3 SCALE: 2:1			TITLE: LOWER LEG LEFT BIPOD			
DESIGN AUTHORITY ARDE PUNE 411021						
DRG No.	1 8 0 4	0 1	0 8	0 1	0 1	0 0 1
	IC	SS	S	AA	A	C
LMG	PART No.		DS CAT No.		AHSP	

DRG No. 1 8 0 4 0 1 0 8 0 1 0 1 0 0 1 0 0 D A
IC SS S AA A C SST

LMG PART No. DS CAT No. AHSP

228

LSS 0 0 0 0
 V D 0 0
 O 2 0 0
 V 1 0
 VV 1 0
 S 8 0
 SS 1 0
 CI 7 0 8 1
 DRG No. 1804 01 08 01 01 002 00DA

GENERAL TOL. : FINE / MEDIUM / COARSE
 CLASS TO IS: 2102
 DRG. CONVENTIONS CONFIRM TO INDIAN STANDARDS
 DIMENSIONS ARE IN mm UNLESS OTHERWISE STATED.

NOTE:
 1.REMOVE ALL SHARP EDGES AND BURR.
 2.HARDNESS: 410 TO 460 HV

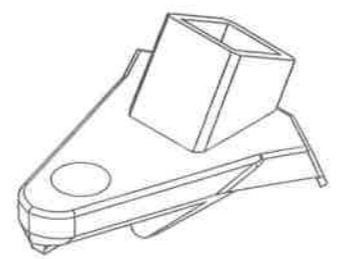
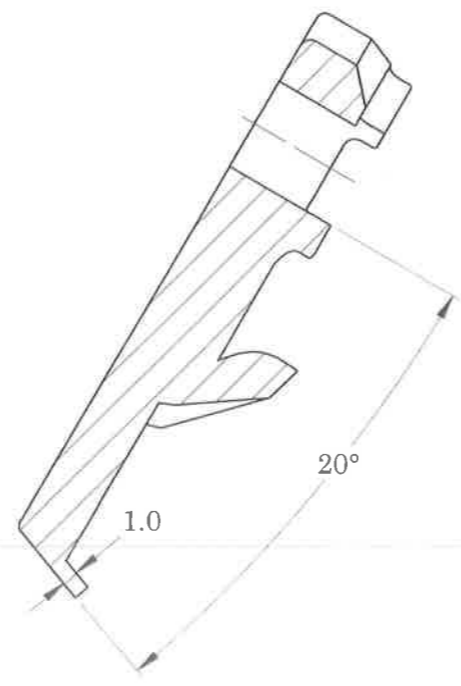
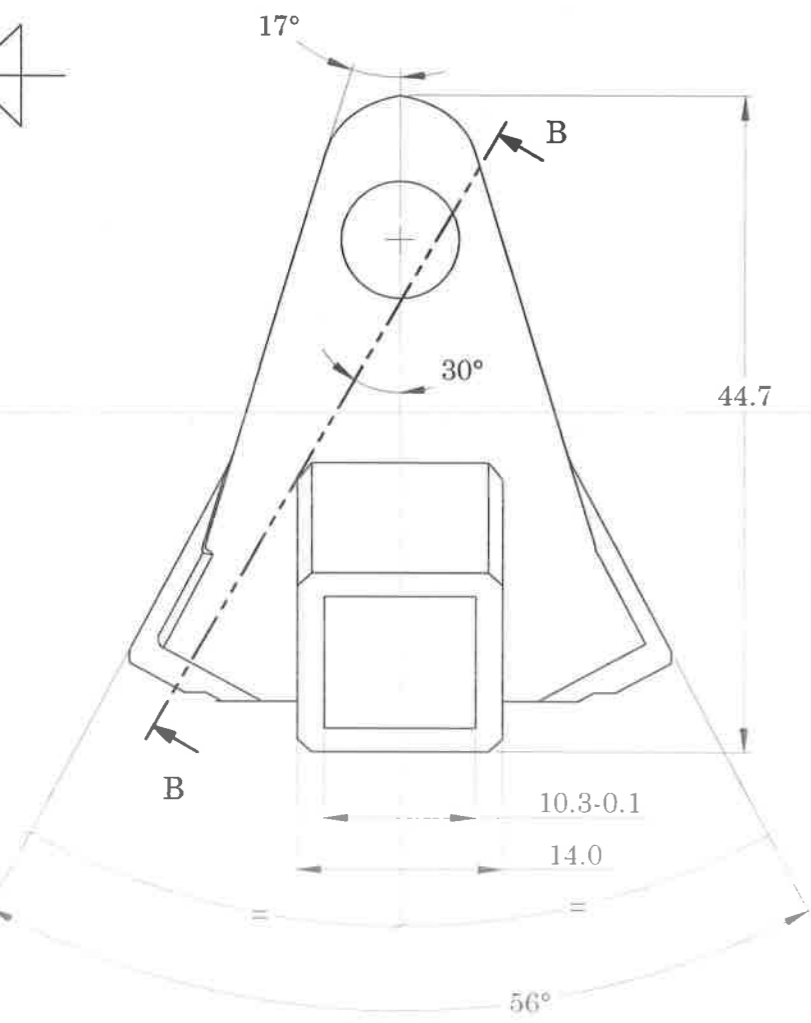
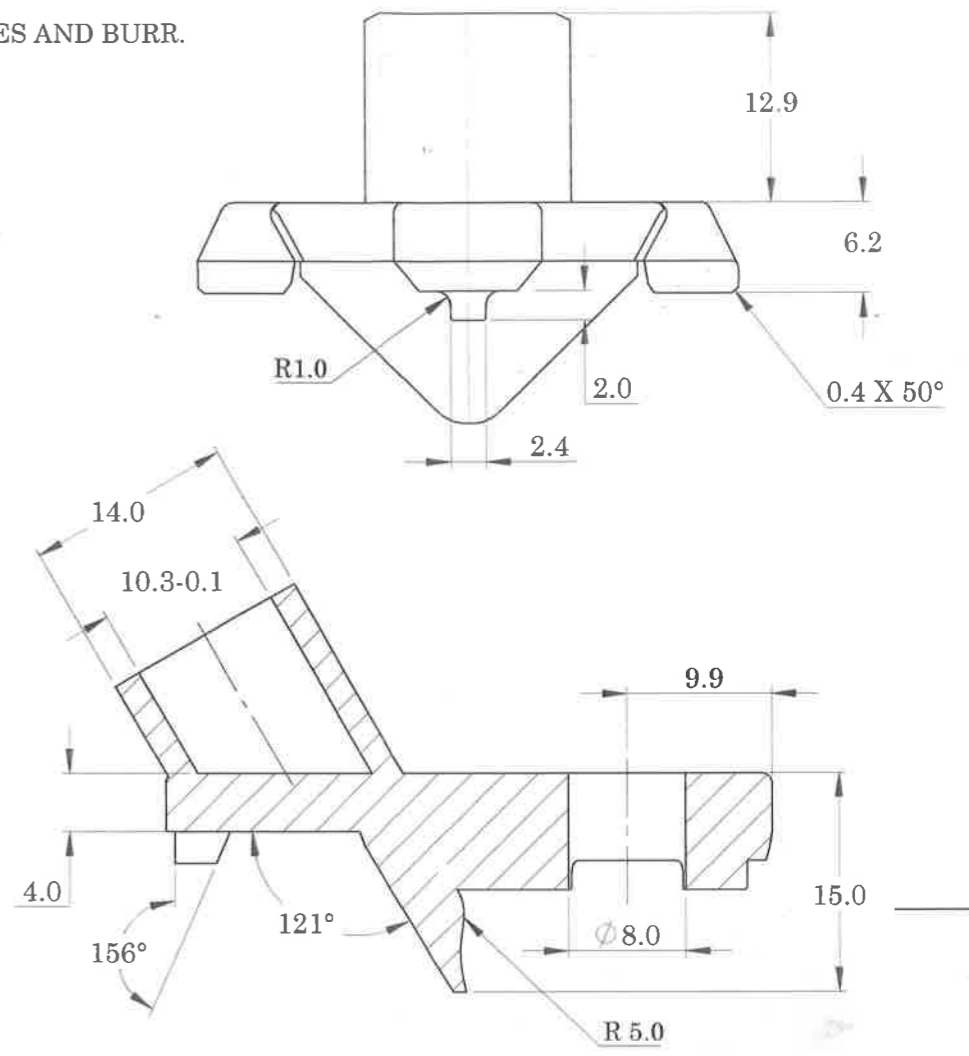
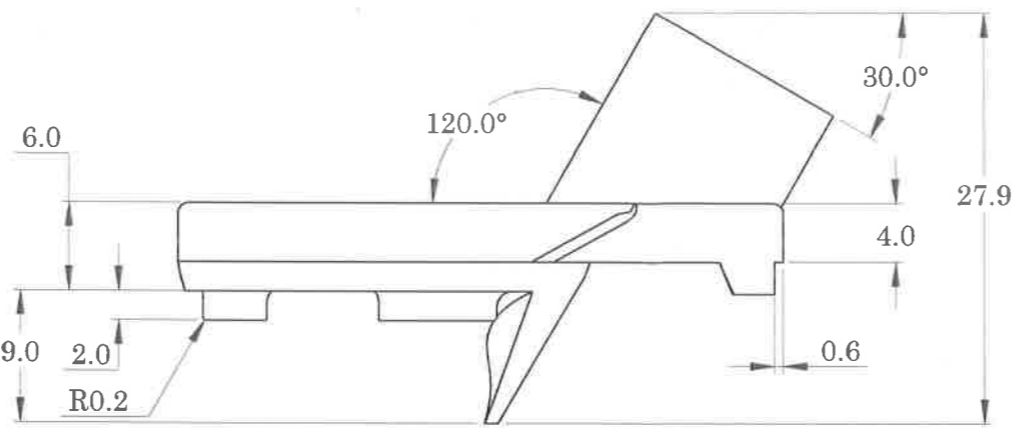
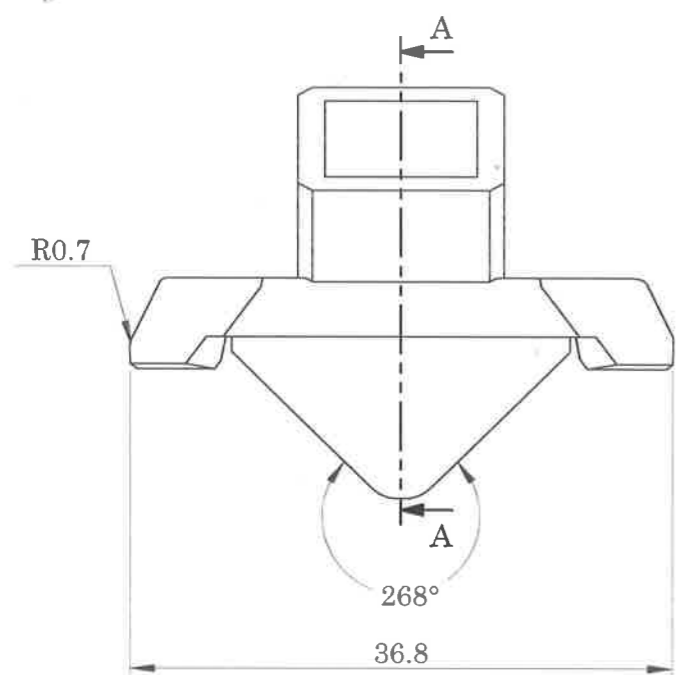

Sr. No.	DATE	AUTHORITY	BRIEF RECORD	ZONE	CD	GO
DRN: HARSH			MATERIAL:			
SIGN:			STEEL TO IS:5517 1993 Gd. 40Ni6Cr4Mo3 (En24)			
DATE: 04/09/2020		CHECKED				
APPD.			PROTECTIVE FINISH:			
DATE: 04/09/2020		FOR DIRECTOR	NIRIDING DULL BLACK MATT FINISH AS PER MIL-S-6090			
SEALED			A COATING THICKNESS : 10-20 MICRONS			
DATE:			TITLE:			
SHEET SIZE: A3		EST. MASS	FOOT BIPOD			
SCALE: 2:1		approx.40.7 gm				
DESIGN AUTHORITY						
ARDE						
PUNE 411021						
DRG No.	1 8 0 4	0 1	0 8	0 1	0 1	0 0 2
	IC	SS	S	AA	A	C
LMG	PART No.		DS CAT No.			AHSP

230

LSS CD 00 100 V 20 VV 10 S 80 SS 10 IC 4081 DRG No. DRG

GENERAL TOL. : FINE / MEDIUM / COARSE ✓ DRG. CONVENTIONS CONFIRM TO INDIAN STANDARDS CLASS TO IS: 2102 DIMENSIONS ARE IN mm UNLESS OTHERWISE STATED.

NOTE: REMOVE ALL SHARP EDGES AND BURR.

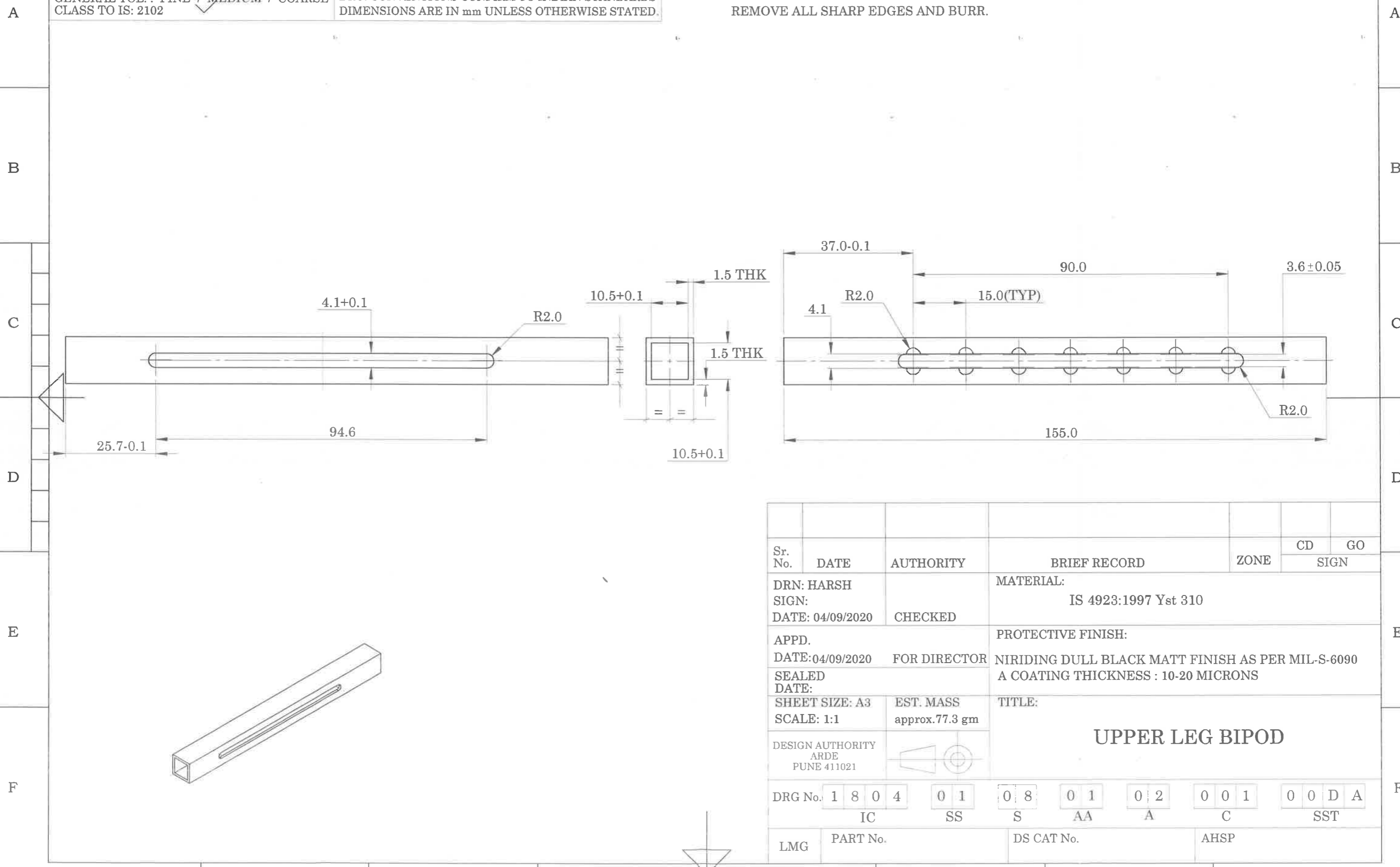

Sr. No.	DATE	AUTHORITY	BRIEF RECORD	ZONE	CD	GO
			MATERIAL:			
			IS 4923:1997 Yst 310			
			PROTECTIVE FINISH:			
			NIRIDING DULL BLACK MATT FINISH AS PER MIL-S-6090			
			A COATING THICKNESS : 10-20 MICRONS			
			TITLE:			
			UPPER LEG BIPOD			
DRG No.	1 8 0 4	0 1	0 8	0 1	0 2	0 0 1
	IC	SS	S	AA	A	C
LMG	PART No.		DS CAT No.			AHSP

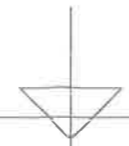

LSS 0000 V 02 VV 01 S 08 SS 01 CI 4081 DRG No.

GENERAL TOL. : FINE / MEDIUM / COARSE CLASS TO IS: 2102 DRG. CONVENTIONS CONFIRM TO INDIAN STANDARDS DIMENSIONS ARE IN mm UNLESS OTHERWISE STATED.

NOTE:
HARDNESS: 340 TO 380 HV
REMOVE ALL SHARP EDGES AND BURR.

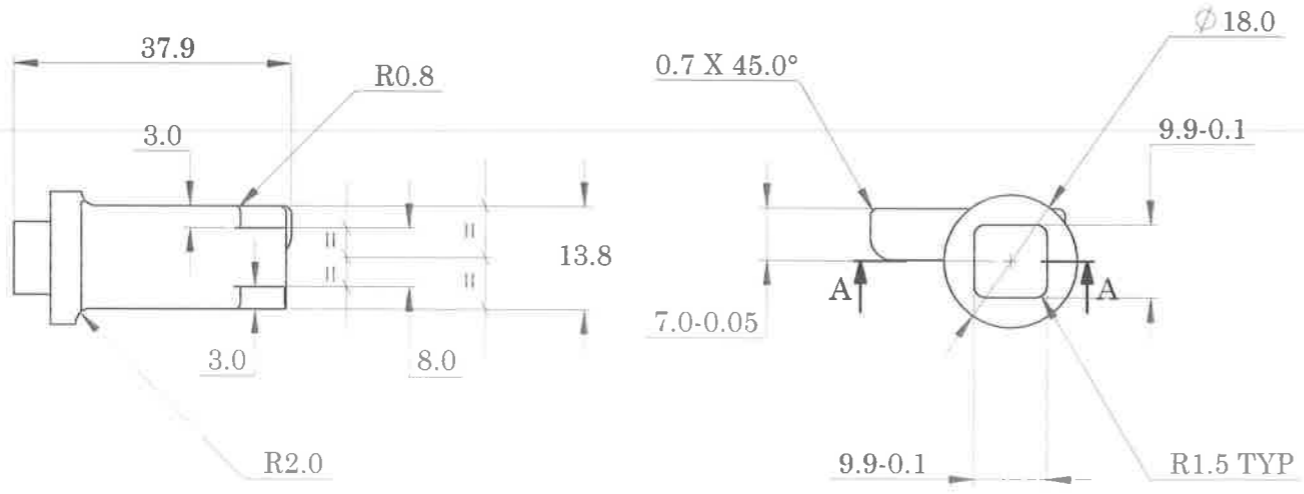
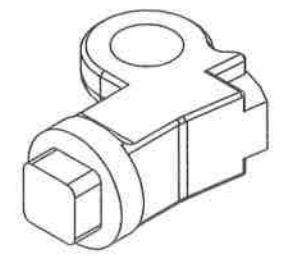
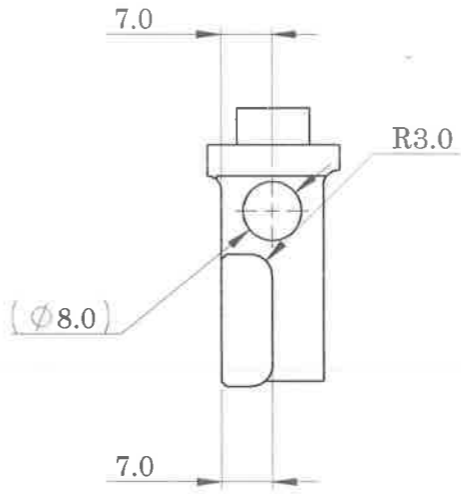
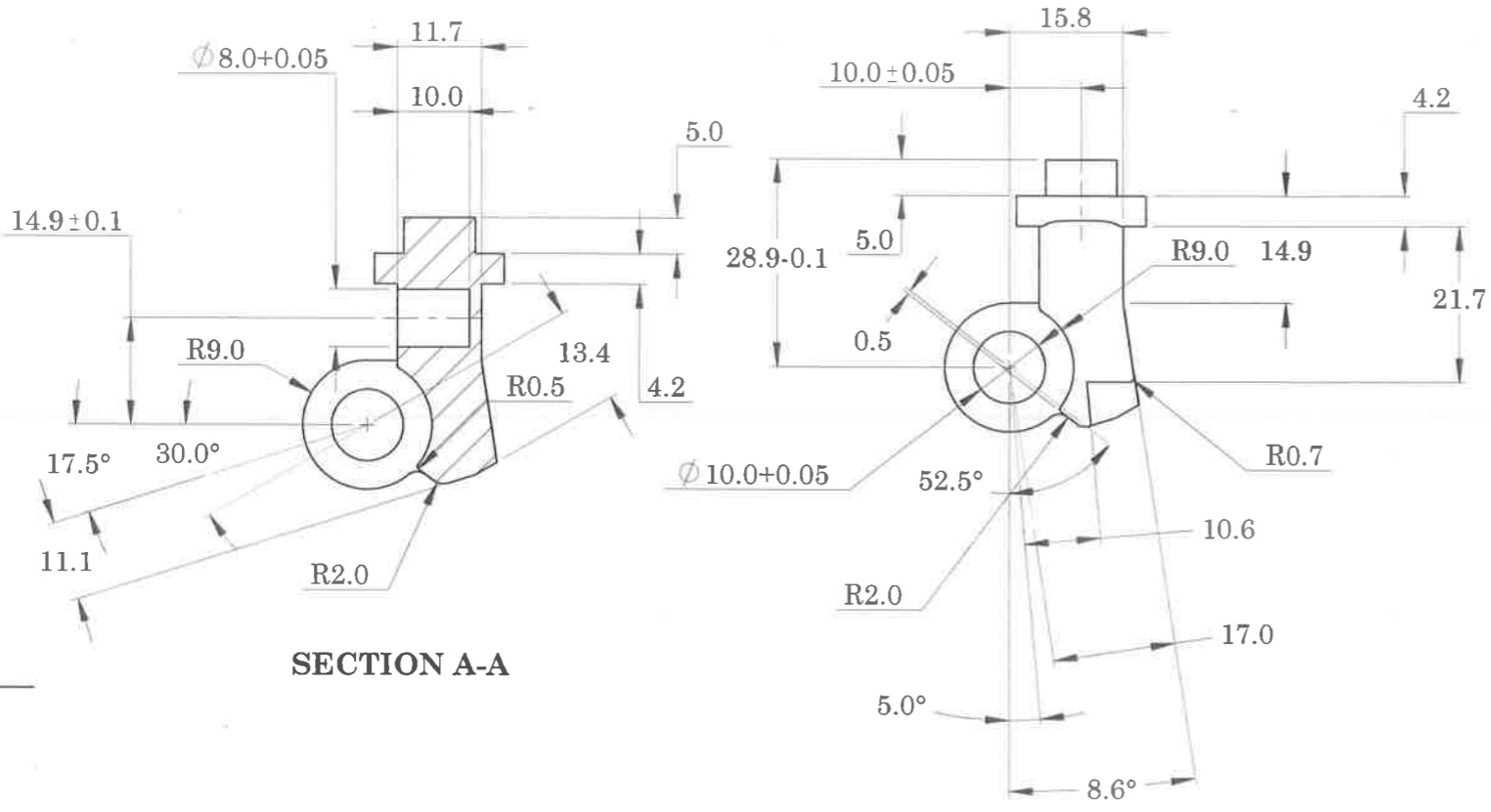

Sr. No.	DATE	AUTHORITY	BRIEF RECORD	ZONE	CD	GO
DRN: HARSH			MATERIAL:			
SIGN:			IS : 5517 1993 Gd. 40Ni6Cr4Mo3 (En24)			
DATE: 04/09/2020		CHECKED				
APPD.			PROTECTIVE FINISH:			
DATE: 04/09/2020		FOR DIRECTOR	NITRIDING DULL BLACK MATT FINISH AS PER MIL-S-6090			
SEALED			COATING THICKNESS: 10-20 MICRONS			
DATE:			TITLE:			
SHEET SIZE: A3		EST. MASS	LATCH BIPOD			
SCALE: 1:1		approx. 46.3 gm				
DESIGN AUTHORITY						
ARDE						
PUNE 411021						
DRG No.	1 8 0 4	0 1	0 8	0 1	0 2	0 0 2
	IC	SS	S	AA	A	C
LMG	PART No.		DS CAT No.			AHSP

DRG No. 1 8 0 4 0 1 0 8 0 1 0 2 0 0 2 0 0 D A

IC SS S AA A C SST

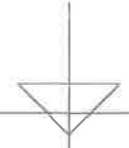

LSS 000 V 00 VV 20 S 80 SS 10 CI 4081 DRG No.

GENERAL TOL. : FINE / MEDIUM / COARSE CLASS TO IS: 2102 DRG. CONVENTIONS CONFIRM TO INDIAN STANDARDS DIMENSIONS ARE IN mm UNLESS OTHERWISE STATED.

ITEM NO.	PART NUMBER	DESCRIPTION	QTY.
1	1804 01 08 02 01 000 00DA	LOWER LEG RIGHT AND FOOT BIPOD WELDING ASSEMBLY.	1
2	1804 01 08 02 02 000 00DA	UPPER LEG BIPOD AND LATCH BIPOD WELDING ASSEMBLY (RIGHT)	1
3	1804 01 08 01 00 001 00DA	PLUNGER BIPOD	1
4	1804 01 08 01 00 002 00DA	SPRING INNER BIPOD	1
5	1804 01 08 01 00 003 00DA	WASHER BIPOD	1
6	STANDARD COMPONENT	DOWEL PIN (ϕ 1.5 x 8.0)	1

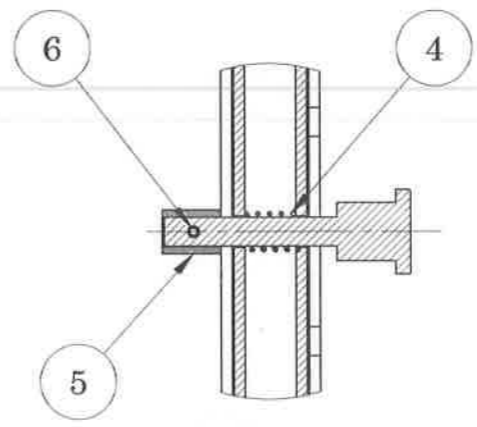
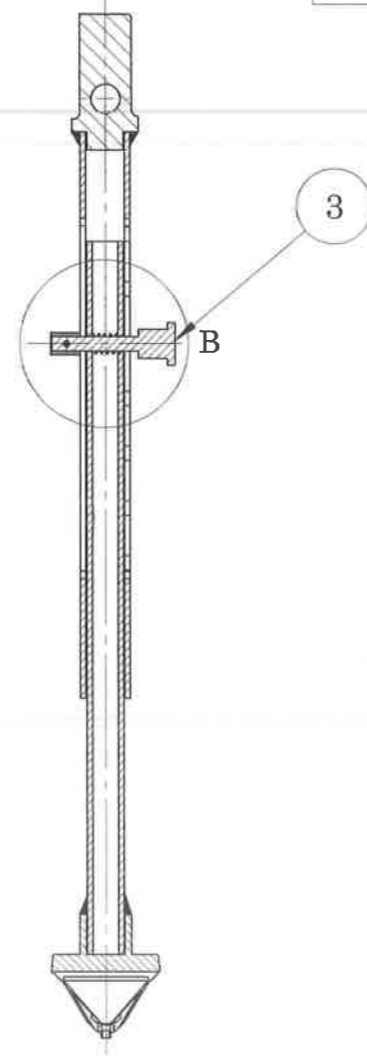
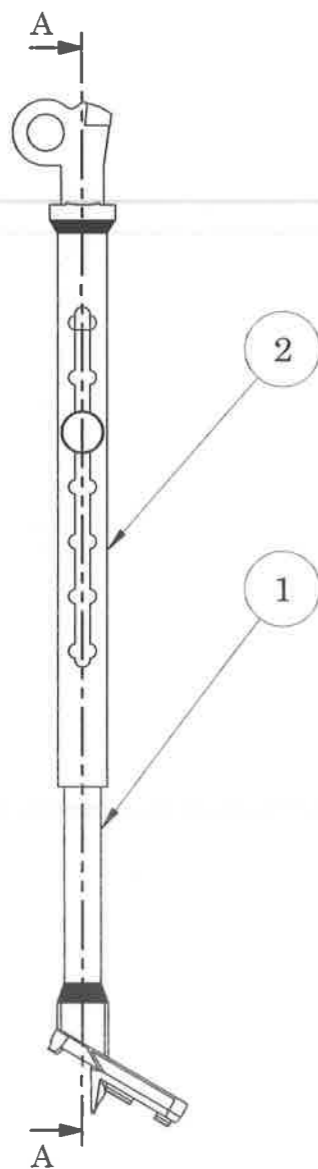

DETAIL B SCALE 1 : 1

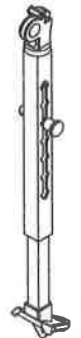

Sr. No.	DATE	AUTHORITY	BRIEF RECORD	ZONE	CD	GO
DRN: HARSH			MATERIAL:			
SIGN:						
DATE: 04/09/2020	CHECKED		PROTECTIVE FINISH:			
APPD.						
DATE: 04/09/2020	FOR DIRECTOR					
SEALED			TITLE:			
DATE:			LEG RIGHT BIPOD ASSEMBLY			
SHEET SIZE: A3	EST. MASS					
SCALE:1:2	approx.250 gm					
DESIGN AUTHORITY						
ARDE						
PUNE 411021						
DRG No.	1 8 0 4	0 1	0 8	0 2	0 0	0 0 0 0 0 0 D A
	IC	SS	S	AA	A	C SST
LMG	PART No.		DS CAT No.			AHSP

A

B

C

D

E

F

A

B

C

D

E

F

1

2

3

4

5

6

7

8

236

JSS	O	V	VV	S	SS	CI
V	0	0	0	1	0	0
1	0	0	2	0	8	0
4	0	1	0	4	0	8
DRG No. 1804 01 08 02 01 001 00DA						

NOTE
REMOVE ALL SHARP EDGES AND BURRS.

GENERAL TOL. : FINE / MEDIUM / COARSE ✓
CLASS TO IS: 2102

DRG. CONVENTIONS CONFIRM TO INDIAN STANDARDS
DIMENSIONS ARE IN mm UNLESS OTHERWISE STATED.

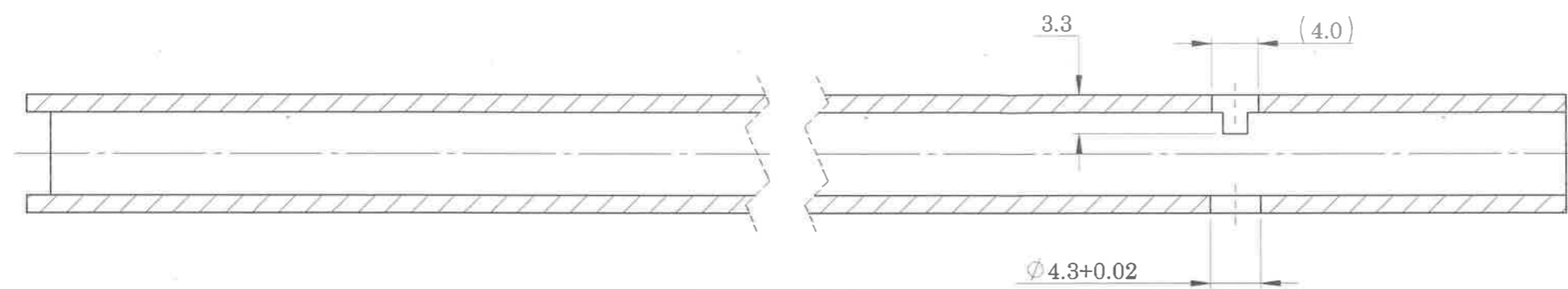

SECTION A-A

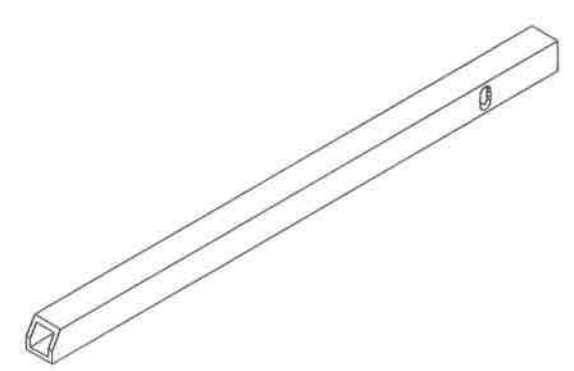
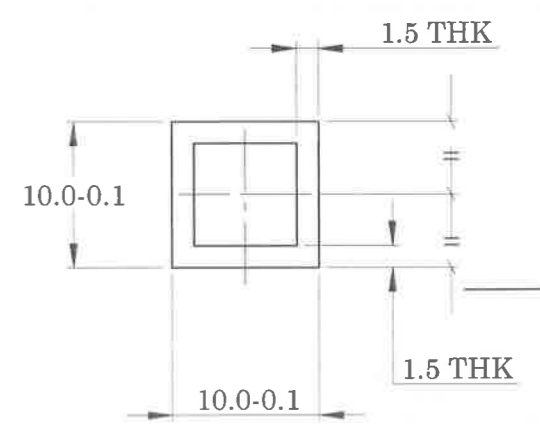
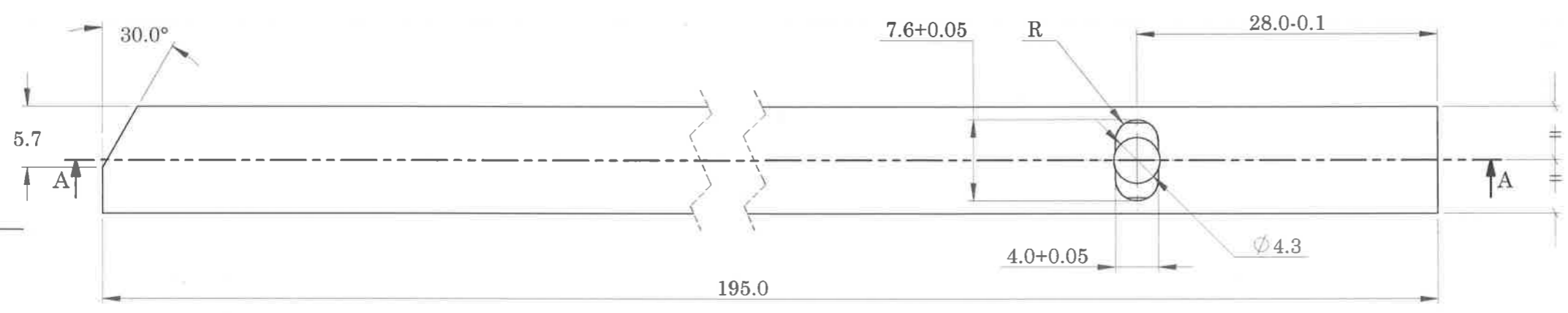

Sr. No.	DATE	AUTHORITY	BRIEF RECORD	ZONE	CD	GO
			MATERIAL:			
			IS 4923:1997 Yst 310			
			PROTECTIVE FINISH:			
			NIRIDING DULL BLACK MATT FINISH AS PER MIL-S-6090			
			A COATING THICKNESS : 10-20 MICRONS			
			TITLE:			
			LOWER LEG RIGHT BIPOD			
DRG No.	1 8 0 4	0 1	0 8	0 2	0 1	0 0 1
	IC	SS	S	AA	A	C
LMG	PART No.		DS CAT No.		AHSP	

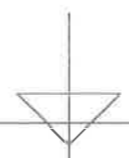

228

LSS 0 0 0 0
 V D 0 0
 O 2 0 0
 V 1 0
 VV 1 0
 S 8 0
 SS 1 0
 OI 7 0 8 1
 DRG No. 1804 01 08 01 01 002 00DA

GENERAL TOL. : FINE / MEDIUM / COARSE
 CLASS TO IS: 2102
 DRG. CONVENTIONS CONFIRM TO INDIAN STANDARDS
 DIMENSIONS ARE IN mm UNLESS OTHERWISE STATED.

NOTE:
 1.REMOVE ALL SHARP EDGES AND BURR.
 2.HARDNESS: 410 TO 460 HV

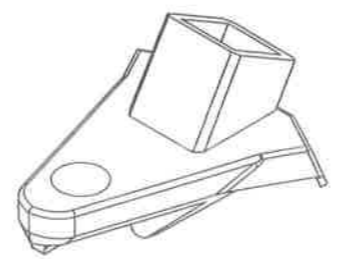
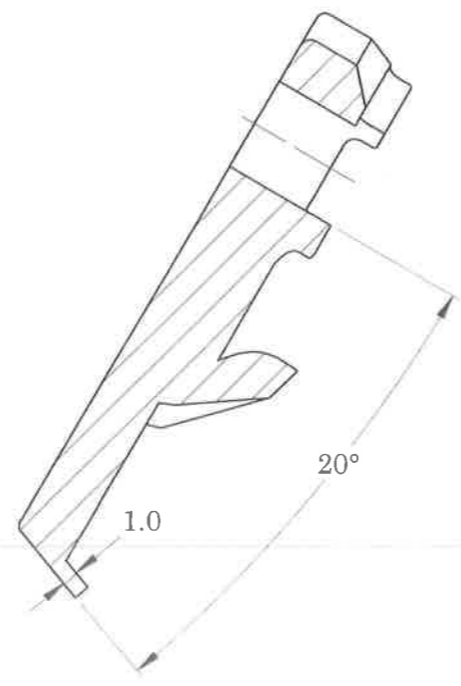
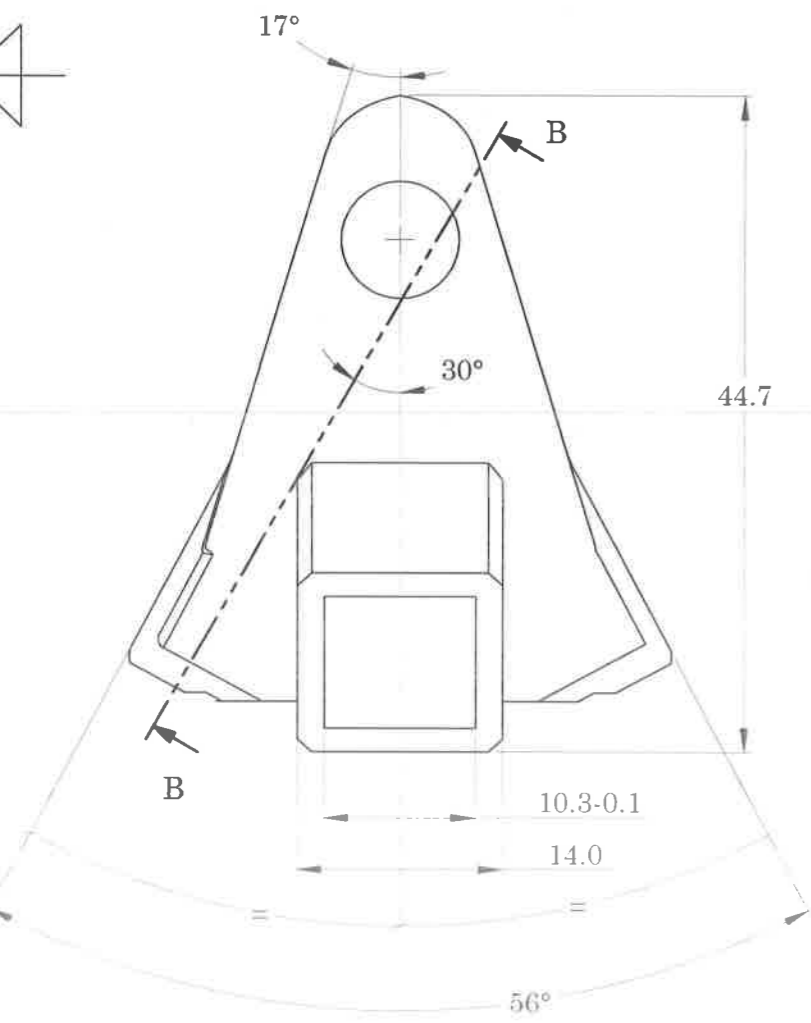
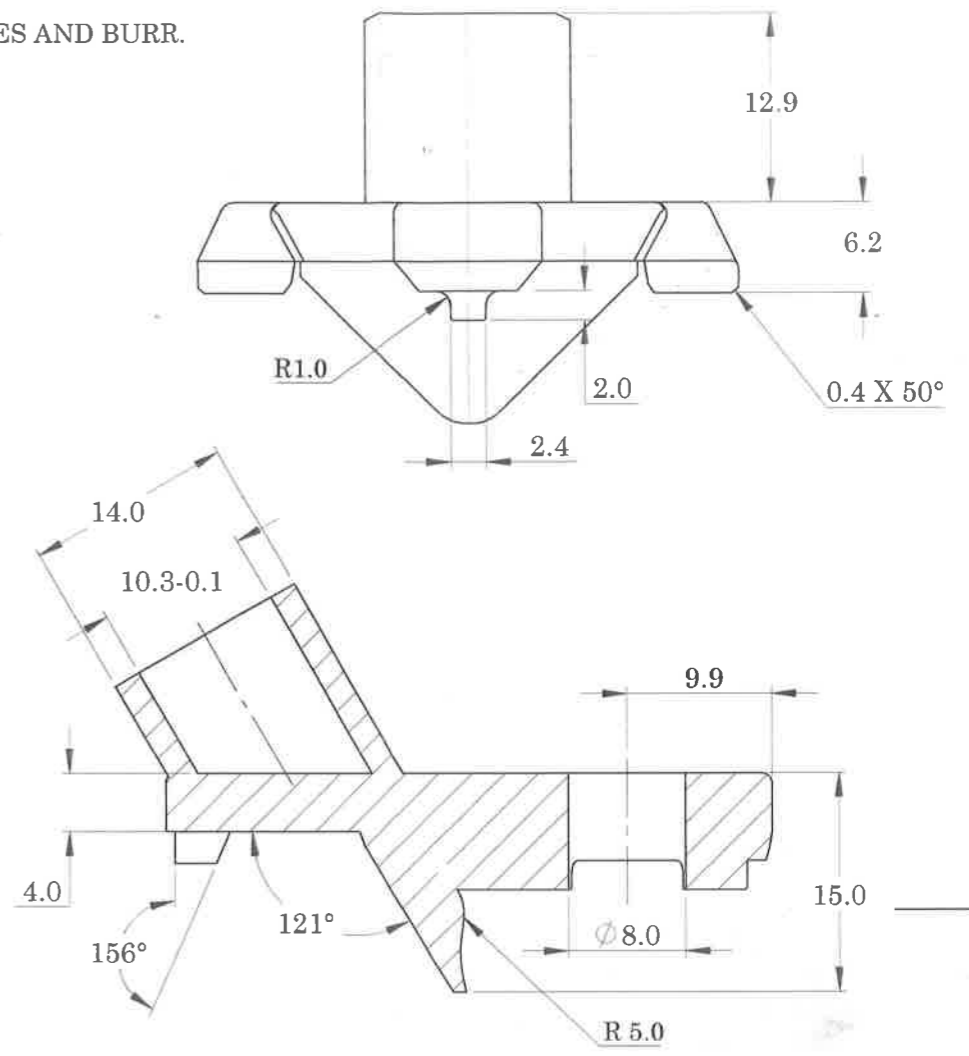
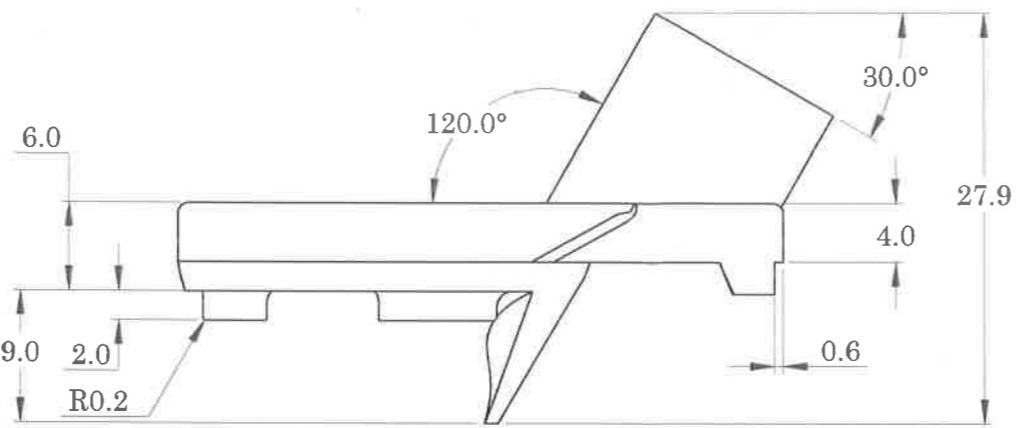
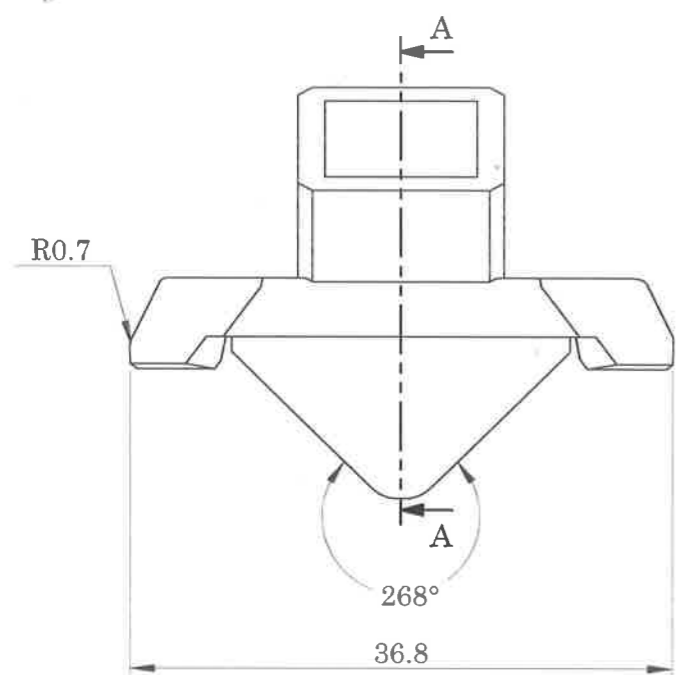

Sr. No.	DATE	AUTHORITY	BRIEF RECORD	ZONE	CD	GO
DRN: HARSH			MATERIAL:			
SIGN:			STEEL TO IS:5517 1993 Gd. 40Ni6Cr4Mo3 (En24)			
DATE: 04/09/2020		CHECKED				
APPD.			PROTECTIVE FINISH:			
DATE: 04/09/2020		FOR DIRECTOR	NIRIDING DULL BLACK MATT FINISH AS PER MIL-S-6090			
SEALED			A COATING THICKNESS : 10-20 MICRONS			
DATE:			TITLE:			
SHEET SIZE: A3		EST. MASS	FOOT BIPOD			
SCALE: 2:1		approx.40.7 gm				
DESIGN AUTHORITY						
ARDE						
PUNE 411021						
DRG No.	1 8 0 4	0 1	0 8	0 1	0 1	0 0 2
	IC	SS	S	AA	A	C
LMG	PART No.		DS CAT No.			AHSP

230

LSS CD 00 100 V 20 VV 10 S 80 SS 10 IC 4081 DRG No. DRG

GENERAL TOL. : FINE / MEDIUM / COARSE ✓ DRG. CONVENTIONS CONFIRM TO INDIAN STANDARDS CLASS TO IS: 2102 DIMENSIONS ARE IN mm UNLESS OTHERWISE STATED.

NOTE: REMOVE ALL SHARP EDGES AND BURR.

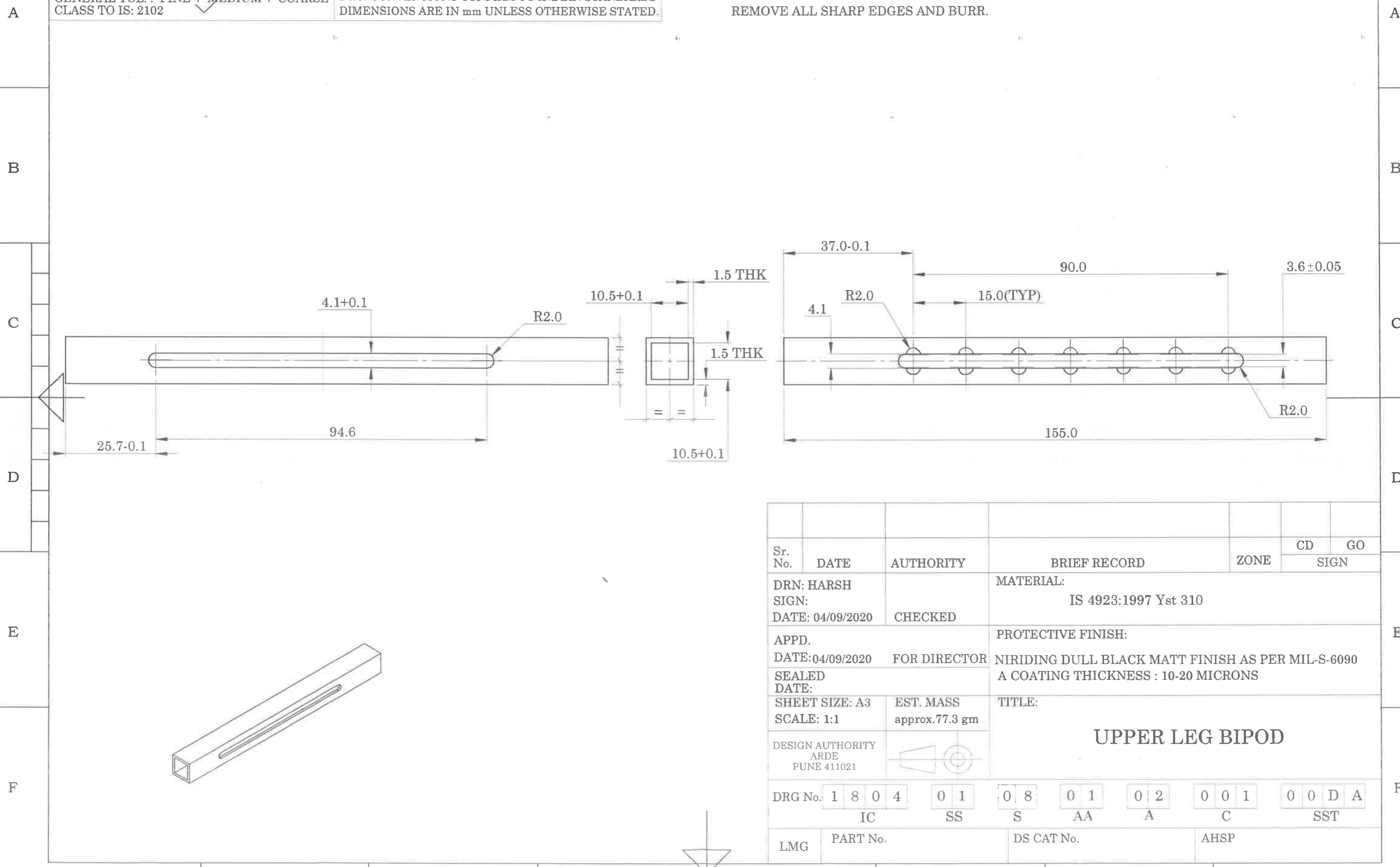

Sr. No.	DATE	AUTHORITY	BRIEF RECORD	ZONE	CD	GO
DRN: HARSH			MATERIAL:			
SIGN:			IS 4923:1997 Yst 310			
DATE: 04/09/2020		CHECKED				
APPD.			PROTECTIVE FINISH:			
DATE: 04/09/2020		FOR DIRECTOR	NIRIDING DULL BLACK MATT FINISH AS PER MIL-S-6090			
SEALED			A COATING THICKNESS : 10-20 MICRONS			
DATE:						
SHEET SIZE: A3		EST. MASS	TITLE:			
SCALE: 1:1		approx. 77.3 gm	UPPER LEG BIPOD			
DESIGN AUTHORITY						
ARDE						
PUNE 411021						
DRG No.	1 8 0 4	0 1	0 8	0 1	0 2	0 0 1
	IC	SS	S	AA	A	C
LMG	PART No.		DS CAT No.			AHSP

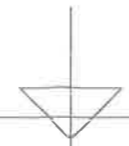

LSS 0000 V 02 VV 01 S 08 SS 01 CI 4081 DRG No.

GENERAL TOL. : FINE / MEDIUM / COARSE CLASS TO IS: 2102 DRG. CONVENTIONS CONFIRM TO INDIAN STANDARDS DIMENSIONS ARE IN mm UNLESS OTHERWISE STATED.

NOTE:
HARDNESS: 340 TO 380 HV
REMOVE ALL SHARP EDGES AND BURR.

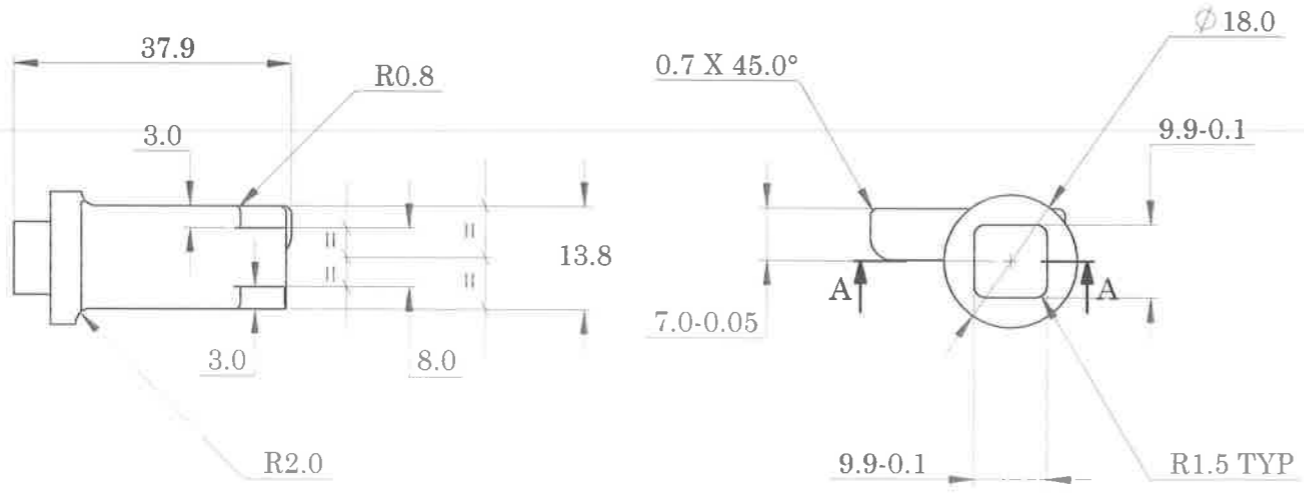
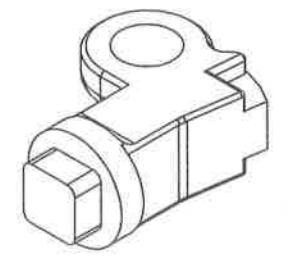
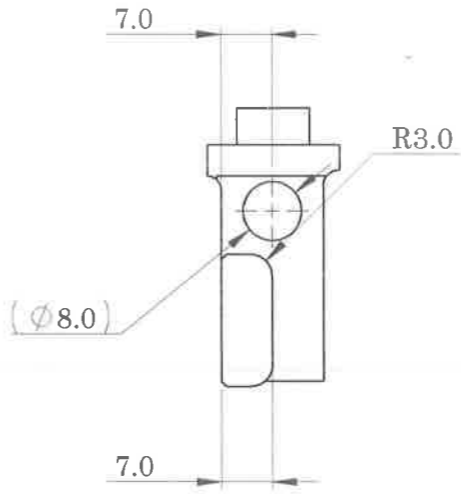
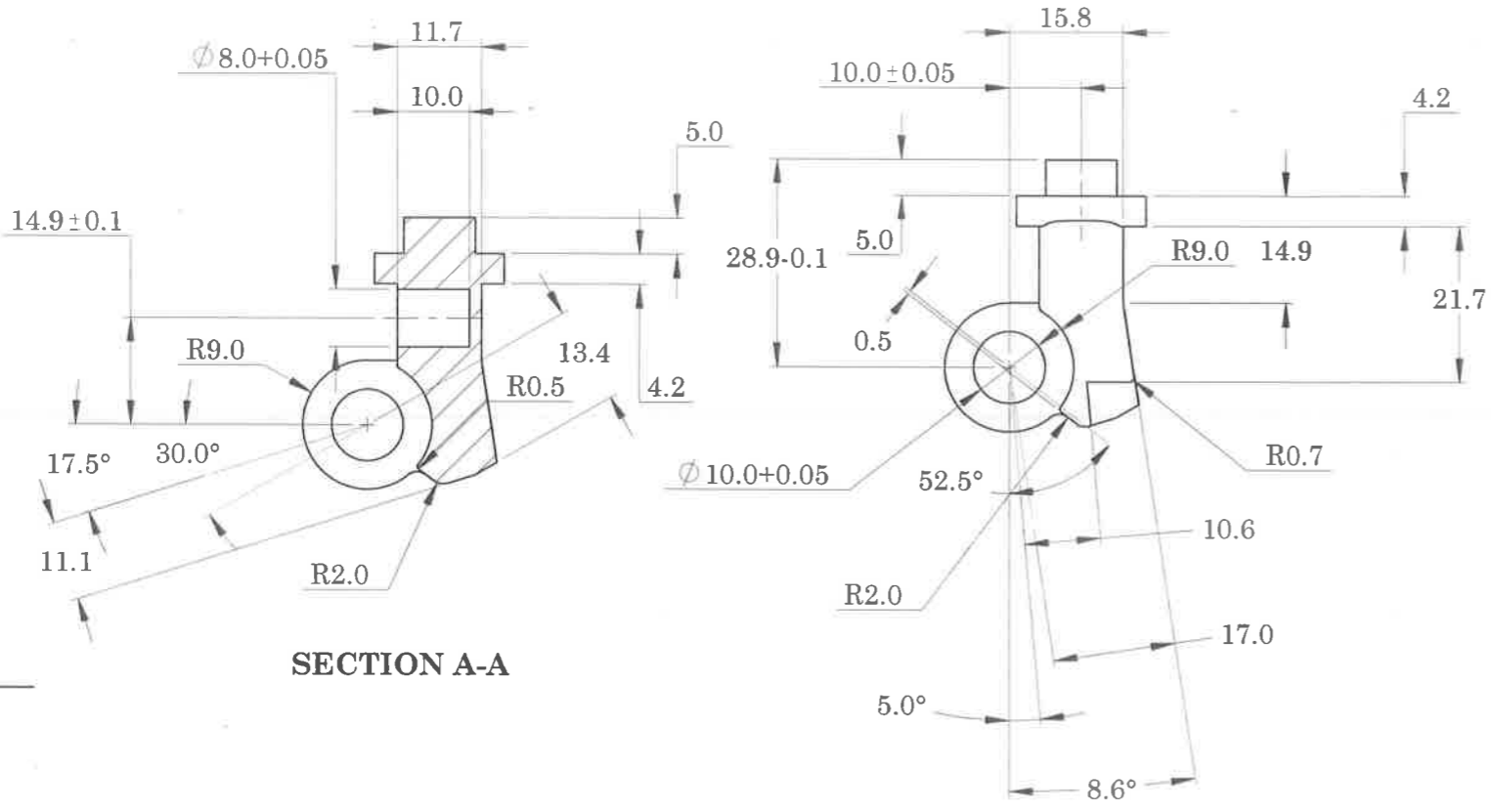

Sr. No.	DATE	AUTHORITY	BRIEF RECORD	ZONE	CD	GO
DRN: HARSH			MATERIAL:			
SIGN:			IS : 5517 1993 Gd. 40Ni6Cr4Mo3 (En24)			
DATE: 04/09/2020		CHECKED	PROTECTIVE FINISH:			
APPD.			NITRIDING DULL BLACK MATT FINISH AS PER MIL-S-6090			
DATE: 04/09/2020		FOR DIRECTOR	COATING THICKNESS: 10-20 MICRONS			
SEALED			TITLE:			
DATE:			LATCH BIPOD			
SHEET SIZE: A3		EST. MASS				
SCALE: 1:1		approx. 46.3 gm				
DESIGN AUTHORITY						
ARDE						
PUNE 411021						
DRG No.	1 8 0 4	0 1	0 8	0 1	0 2	0 0 2
	IC	SS	S	AA	A	C
LMG	PART No.		DS CAT No.			AHSP

DRG No. 1 8 0 4 0 1 0 8 0 1 0 2 0 0 2 0 0 D A

IC SS S AA A C SST

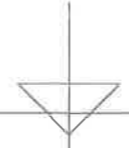

232

DRG No. 1 8 0 4 0 1 0 8 0 1 0 0 1 0 0 0 1 0 0 0

GENERAL TOL. : FINE / MEDIUM / COARSE CLASS TO IS: 2102

DRG. CONVENTIONS CONFIRM TO INDIAN STANDARDS DIMENSIONS ARE IN mm UNLESS OTHERWISE STATED.

NOTE:
HARDNESS: 410 TO 460 HV.
REMOVE ALL SHARP EDGES AND BURRS.

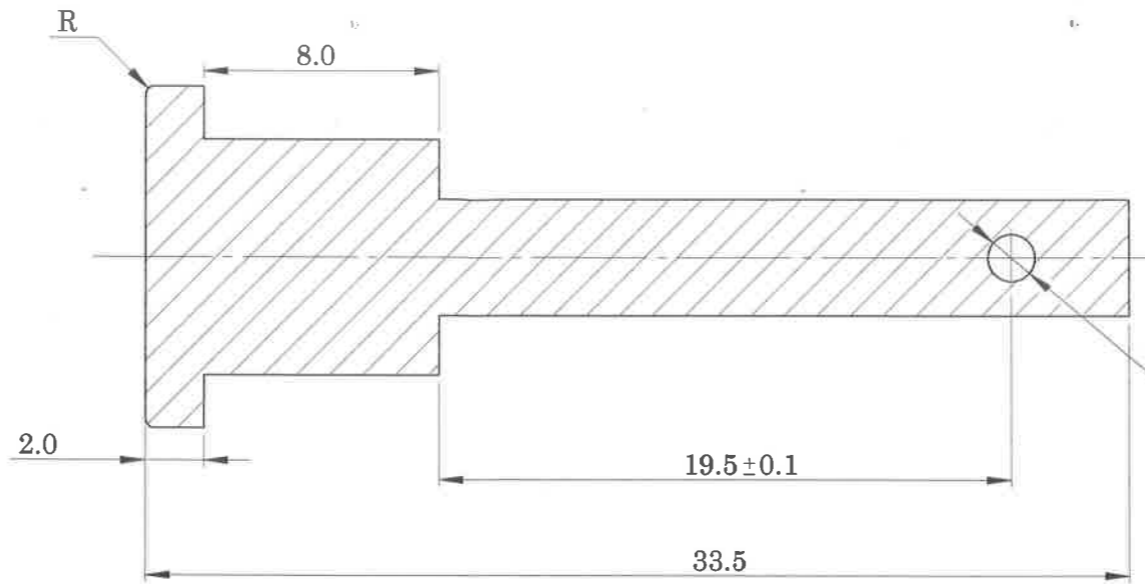
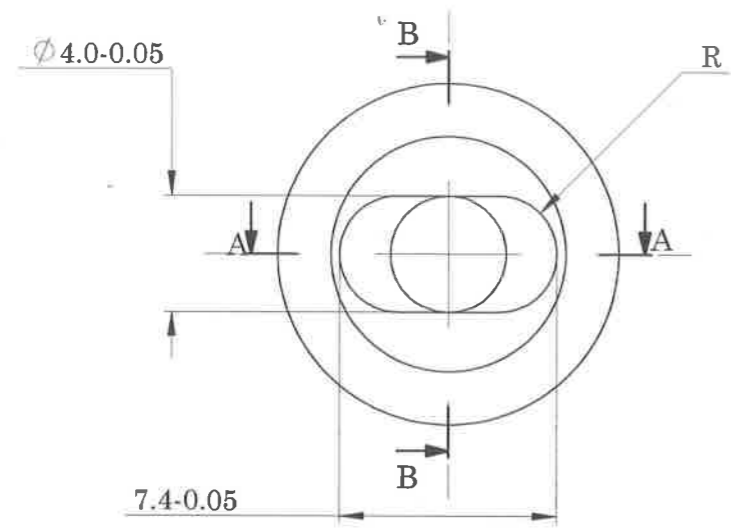

SECTION B-B

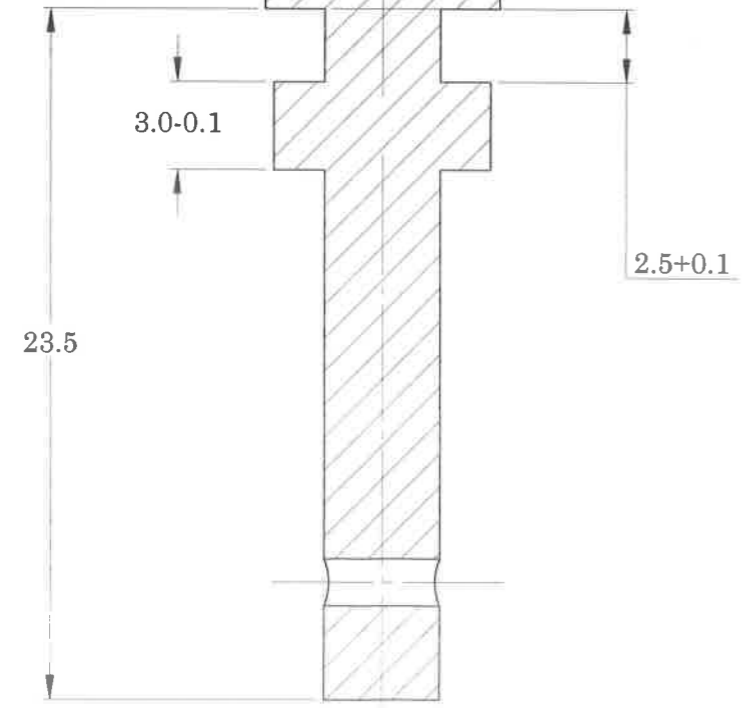
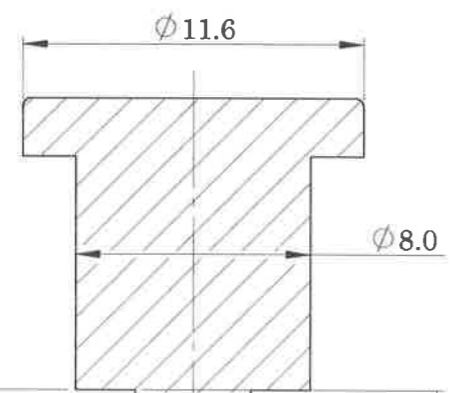

SECTION A-A

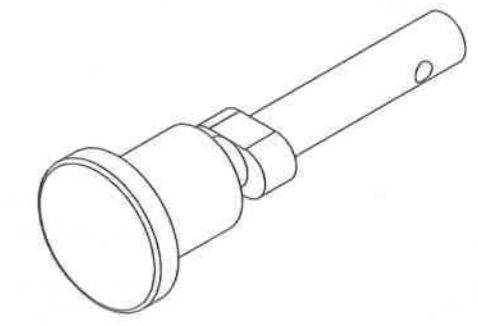

Sr. No.	DATE	AUTHORITY	BRIEF RECORD	ZONE	CD	GO
			MATERIAL:			
			IS : 5517 1993 Gd. 40Ni6Cr4Mo3 (En24)			
			PROTECTIVE FINISH:			
			NITRIDING DULL BLACK MATT FINSH AS PER MIL-S-6090			
			A COATING THICKNESS : 10-20 MICRONS			
			TITLE:			
			PLUNGER BIPOD			
DRG No.	1 8 0 4	0 1	0 8	0 1	0 0	0 0 1 0 0 D A
	IC	SS	S	AA	A	C SST
LMG	PART No.		DS CAT No.		AHSP	

247

JSS V D 0 0 O I 0 0 V 0 0 VV 0 0 S 8 0 SS I 0 OI 4 0 8 1 DRG No. 1804

GENERAL TOL. : FINE / MEDIUM / COARSE CLASS TO IS: 2102 DRG. CONVENTIONS CONFIRM TO INDIAN STANDARDS DIMENSIONS ARE IN mm UNLESS OTHERWISE STATED.

NOTE:
HARDNESS: 340 TO 380 HV
REMOVE ALL SHARP EDGES AND BURRS

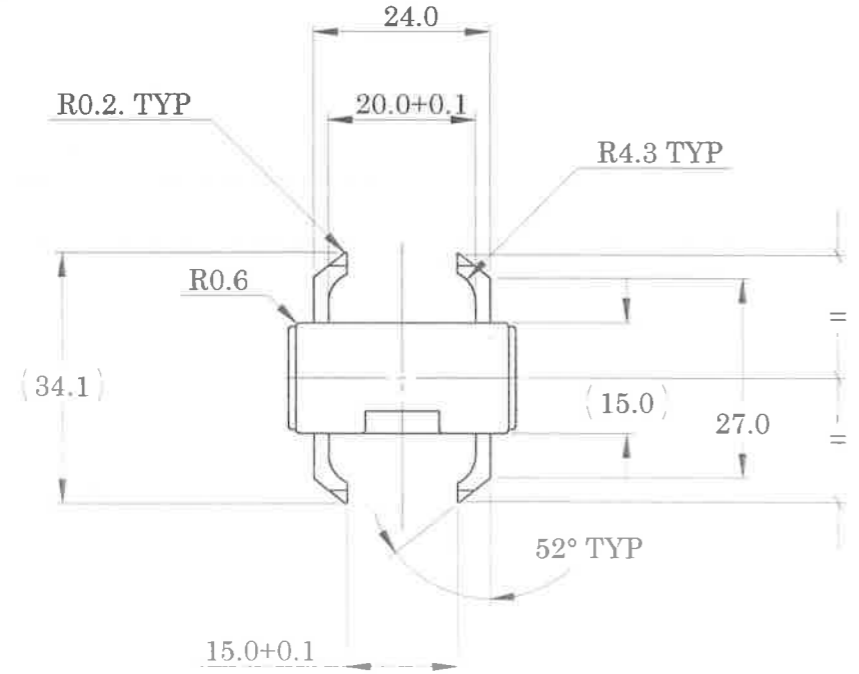
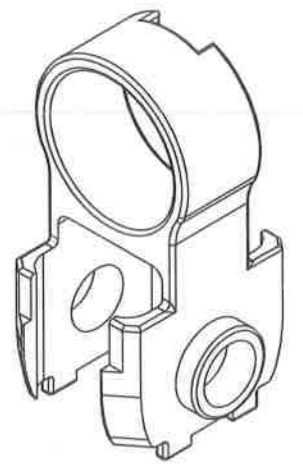
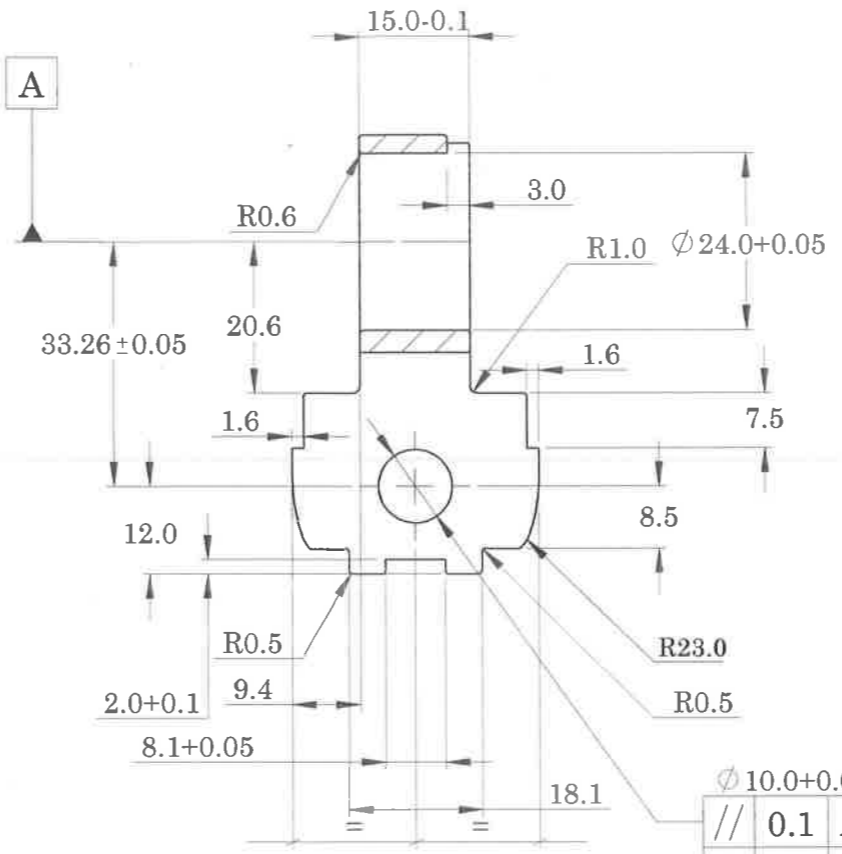
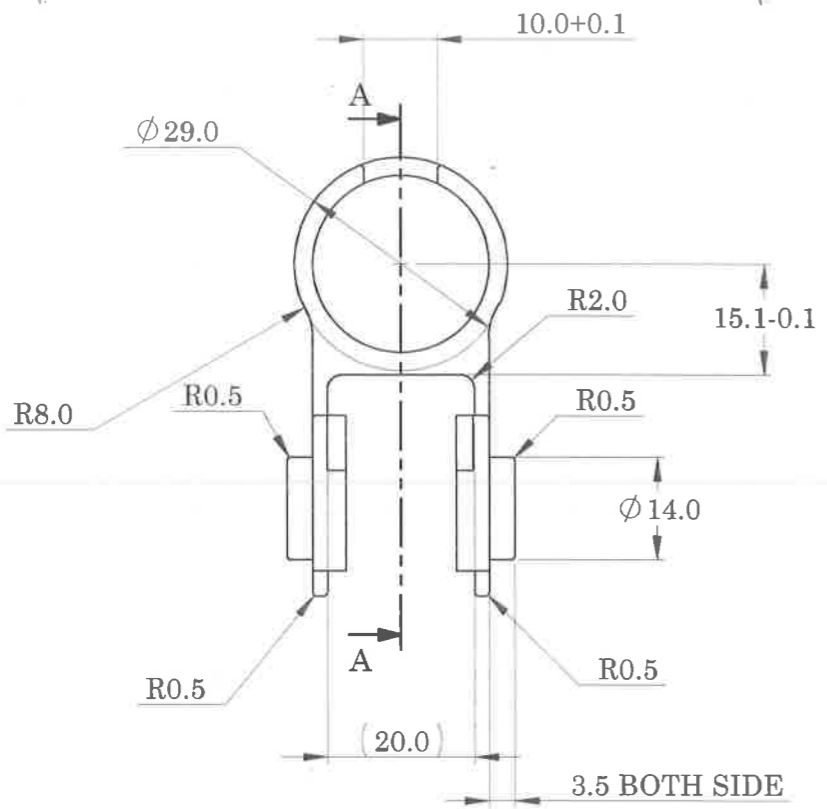

SECTION A-A

Sr. No.	DATE	AUTHORITY	BRIEF RECORD	ZONE	CD	GO
DRN: HARSH			MATERIAL:			
SIGN:			STEEL TO IS :5517 1993 Gd 40 NiCr4Mo3(EN-24)			
DATE: 04/09/2020		CHECKED	PROTECTIVE FINISH:			
APPD.			NITRIDING DULL BLACK MATT FINISH AS PER MIL-S-6090			
DATE: 04/09/2020		FOR DIRECTOR	A COATING THICKNESS : 10 -20 MICRONS			
SEALED			TITLE:			
DATE:			HOUSING SLEEVE BIPOD			
SHEET SIZE: A3		EST. MASS				
SCALE: 1:1		approx. 59.0 gm				
DESIGN AUTHORITY						
ARDE						
PUNE 411021						
DRG No.	1 8 0 4	0 1	0 8	0 0	0 0	0 0 1
	IC	SS	S	AA	A	C
LMG	PART No.		DS CAT No.			AHSP

A

B

C

D

E

F

A

B

C

D

E

F

1

2

3

4

5

6

7

8

248

LSS	C	V	VV	S	SS	IC
V	0	0	0	0	0	0
0	0	0	0	0	0	0
0	0	0	0	0	0	0

GENERAL TOL. : FINE / MEDIUM / COARSE CLASS TO IS: 2102

DRG. CONVENTIONS CONFIRM TO INDIAN STANDARDS DIMENSIONS ARE IN mm UNLESS OTHERWISE STATED.

NOTE:
 1.REMOVE ALL SHARP EDGES AND BURR.
 2.HARDNESS: 340 TO 380 HV

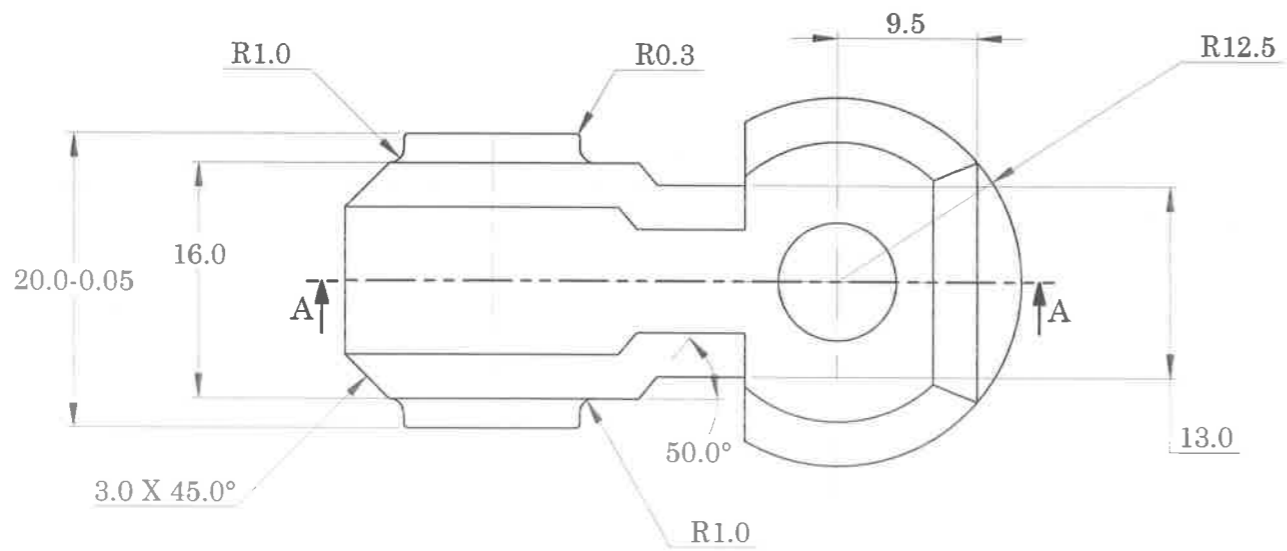
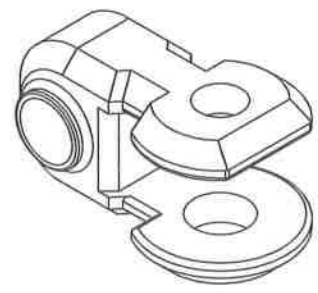
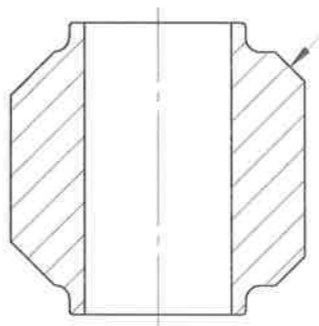
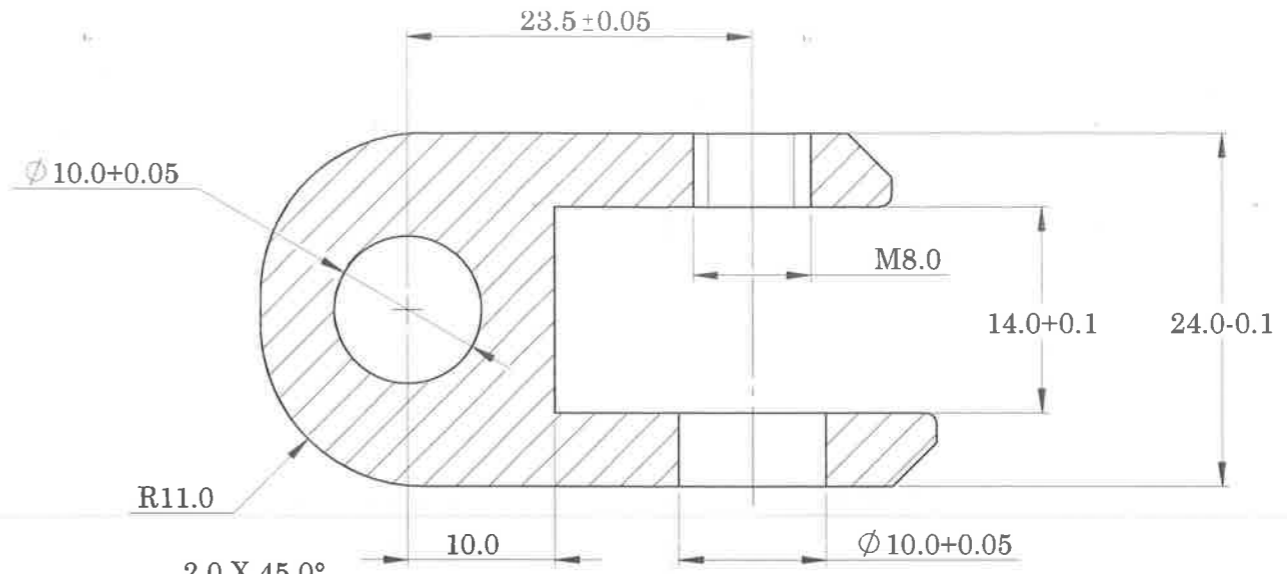
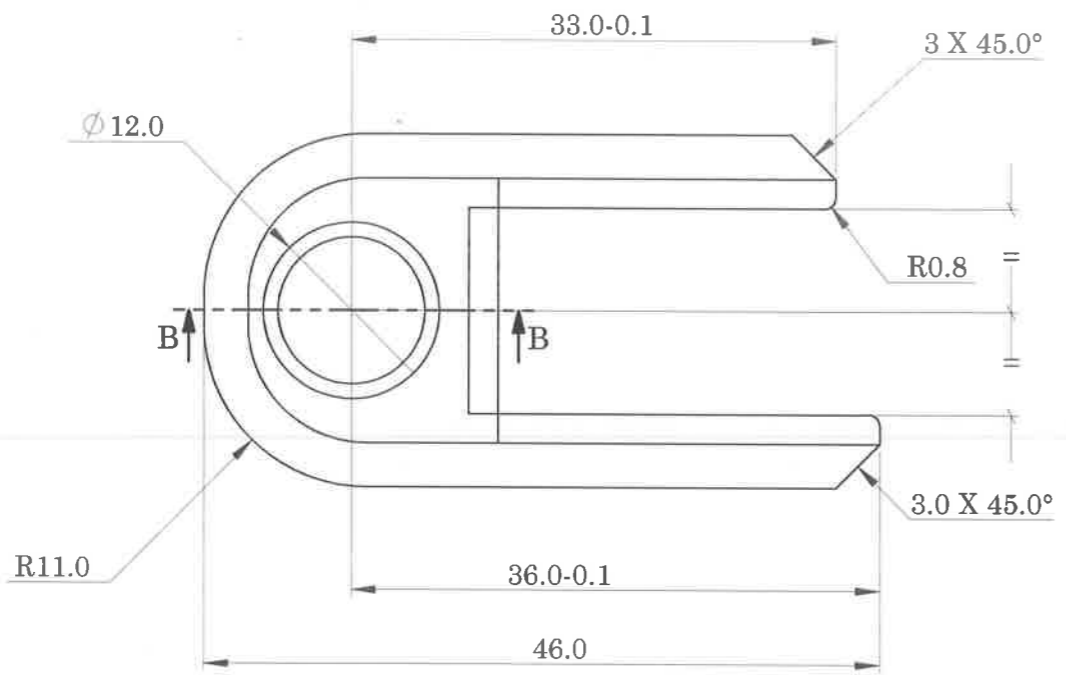

Sr. No.	DATE	AUTHORITY	BRIEF RECORD	ZONE	CD	GO
DRN: HARSH			MATERIAL:			
SIGN:			STEEL TO IS:5517 1993 Gd. 40Ni6Cr4Mo3 - (En24)			
DATE: 04/09/2020		CHECKED	PROTECTIVE FINISH:			
APPD.			NIRIDING DULL BLACK MATT FINISH AS PER MIL-S-6090			
DATE: 04/09/2020		FOR DIRECTOR	COATING THICKNESS : 10-20 MICRONS			
SEALED			TITLE:			
DATE:			SLEEVE BIPOD			
SHEET SIZE: A3		EST. MASS				
SCALE: 2:1		approx. 70.2 gm				
DESIGN AUTHORITY						
ARDE						
PUNE 411021						

DRG No. 1 8 0 4 0 1 0 8 0 0 0 0 0 0 2 0 0 D A

IC SS S AA A C SST

LMG PART No. DS CAT No. AHSP

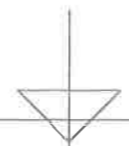

229

1	2	3	4
LSS	C	V	VV
V	0	2	1
0	0	0	8
0	0	0	1
0	0	0	0
4	0	8	1

GENERAL TOL. : FINE / MEDIUM / COARSE DRG. CONVENTIONS CONFIRM TO INDIAN STANDARDS CLASS TO IS: 2102 DIMENSIONS ARE IN mm UNLESS OTHERWISE STATED.

ITEM NO.	PART NUMBER	DESCRIPTION	QTY.
1	UPPER LEG BIPOD	1804 01 08 01 02 001 00DA	1
2	LATCH BIPOD	1804 01 08 01 02 002 00DA	1

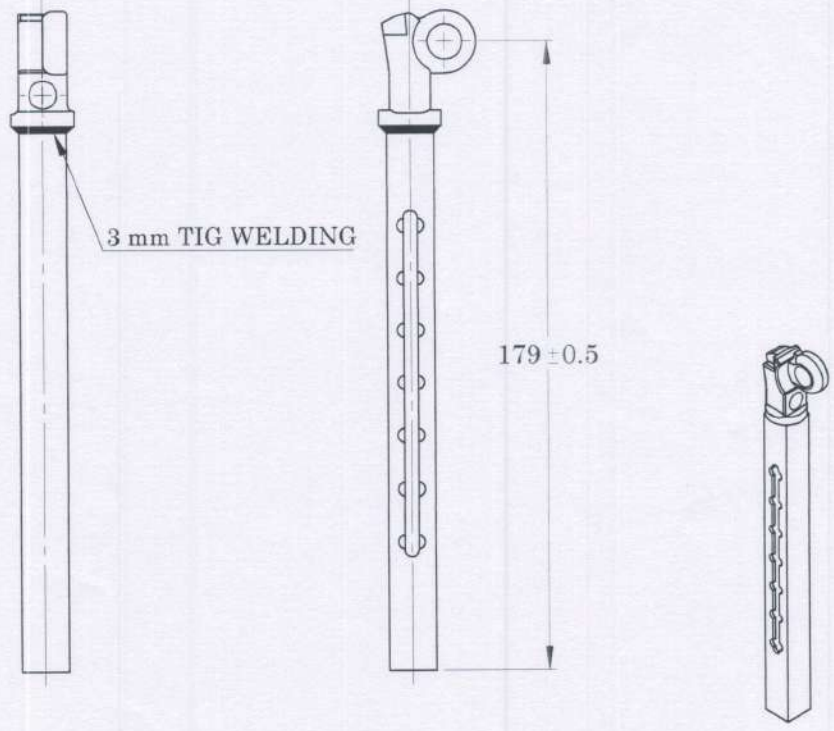

NOTE: REMOVE ALL SHARP EDGES AND BURR.

Sr. No.	DATE	AUTHORITY	BRIEF RECORD	ZONE	CD	GO
					SIGN	

DRN: HARSH
SIGN: _____
DATE: 04/09/2020 CHECKED

APPD. _____
DATE: 04/09/2020 FOR DIRECTOR

SEALED _____
DATE: _____

MATERIAL: _____

PROTECTIVE FINISH: _____

SHEET SIZE: A4 EST. MASS approx. 123.3 gm TITLE: UPPER LEG BIPOD AND LATCH BIPOD WELDING ASSEMBLY (LEFT)

SCALE: 1:2

DESIGN AUTHORITY ARDE PUNE 411021

DRG No.	1	8	0	4	0	1	0	8	0	1	0	2	0	0	0	0	0	D	A
	IC				SS		S	AA		A	C			SST					

LMG	PART No.	DS CAT No.	AHSP
-----	----------	------------	------

233

DRG.No. 1804 0108 0100 002 00DA

GEN. TOL. FINE/MEDIUM/COARSE CLASS TO IS: 2102 ✓ DRG. CONVENTIONS CONFIRM TO INDIAN STD. DIMN. IN mm UNLESS OTHERWISE STATED

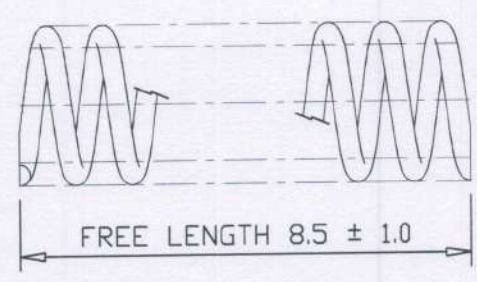
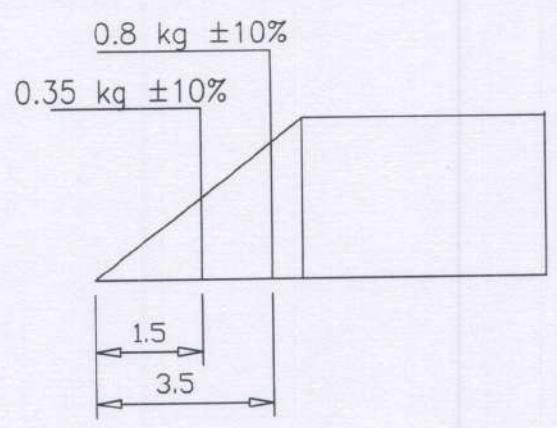

- NOTES :
1. TO BE STRESS RELIEVED
 2. WIRE DIA : $\phi 0.6$
 3. MEAN DIA : $\phi 4.9 \pm 0.2$
 4. NO. OF EFFECTIVE COILS: 5 Nos
 5. WOUND : LH OR RH
 6. CRAMP TEST : SPRING TO BE TESTED BEFORE GAUGING BY COMPRESSION TO SOLID LENGTH FOR A PERIOD OF 24 HRS AFTER WHICH IT MUST CONFIRM TO FREE LENGTH.
 7. ONE COIL OF EACH END TO BE CLOSED IN AND GROUND SQ. TO THE AXIS OF THE COIL, LEAVING 3/4 OF COIL AT EACH END NON EFFECTIVE.

Sr. No.	DATE	AUTHORITY	BRIEF RECORD	ZONE	CD	GO
					SIGN	
DRN.HARSH	DATE:04/09/2020	CHD.	MATERIAL : STEEL WIRE TO IS:4454 (PT I) 2001 DM			
APPD.	DATE	FOR DIRECTOR	PROTECTIVE FINISH :			
SEALED	DATE		PHOSPHATED TO SPECJSS-0465-01-1988 CLASS II OIL FINISH			
SCALE:- NTŞ	EST. MASS		TITLE :			
DESIGN AUTHORITY ARDE PUNE 411021			SPRING INNER BIPOD			

DRG.No. 1804 0108 0100 002 00DA

234

1	2	3	4																								
LSS V D 0 0	C E 0 0	V 0 0	VV 1 0																								
C 8 0	SS 1 0	CI 4 0 8 1	DRG No.																								
A		A																									
GENERAL TOL. : FINE / MEDIUM / COARSE CLASS TO IS: 2102		DRG. CONVENTIONS CONFIRM TO INDIAN STANDARDS DIMENSIONS ARE IN mm UNLESS OTHERWISE STATED.																									
B			B																								
C			C																								
D	<p>NOTE:</p> <p>1.REMOVE ALL SHARP EDGES AND BURRS.</p> <p>2.HARDNESS: 410 TO 460 HV</p>		D																								
E	<table border="1" style="width:100%; border-collapse: collapse;"> <tr> <td style="width:15%;">Sr. No.</td> <td style="width:15%;">DATE</td> <td style="width:20%;">AUTHORITY</td> <td style="width:30%;">BRIEF RECORD</td> <td style="width:10%;">ZONE</td> <td style="width:10%;">CD SIGN</td> <td style="width:10%;">GO SIGN</td> </tr> <tr> <td></td> <td></td> <td></td> <td></td> <td></td> <td></td> <td></td> </tr> </table>		Sr. No.	DATE	AUTHORITY	BRIEF RECORD	ZONE	CD SIGN	GO SIGN								E										
Sr. No.	DATE	AUTHORITY	BRIEF RECORD	ZONE	CD SIGN	GO SIGN																					
F	<table border="1" style="width:100%; border-collapse: collapse;"> <tr> <td style="width:15%;">DRG No.</td> <td style="width:15%;">1 8 0 4</td> <td style="width:15%;">0 1</td> <td style="width:15%;">0 8</td> <td style="width:15%;">0 1</td> <td style="width:15%;">0 0</td> <td style="width:15%;">0 0 3</td> <td style="width:15%;">0 0 D A</td> </tr> <tr> <td></td> <td>IC</td> <td>SS</td> <td>S</td> <td>AA</td> <td>A</td> <td>C</td> <td>SST</td> </tr> <tr> <td>LMG</td> <td>PART No.</td> <td colspan="2">DS CAT No.</td> <td colspan="4">AHSP</td> </tr> </table>		DRG No.	1 8 0 4	0 1	0 8	0 1	0 0	0 0 3	0 0 D A		IC	SS	S	AA	A	C	SST	LMG	PART No.	DS CAT No.		AHSP				F
DRG No.	1 8 0 4	0 1	0 8	0 1	0 0	0 0 3	0 0 D A																				
	IC	SS	S	AA	A	C	SST																				
LMG	PART No.	DS CAT No.		AHSP																							

237

1	2	3	4
LSS	C	V	SS
V D 0 0	0 0 0	1 0	1 0
DRG No.	DRG	DRG	DRG
1 8 0 4	0 1	0 8	0 1

GENERAL TOL.: FINE / MEDIUM / COARSE CLASS TO IS: 2102
 DRG. CONVENTIONS CONFIRM TO INDIAN STANDARDS DIMENSIONS ARE IN mm UNLESS OTHERWISE STATED.

ITEM NO.	PART NUMBER	DESCRIPTION	QTY.
1	LOWER LEG RIGHT BIPOD	1804 01 08 02 01 001 00DA	1
2	FOOT BIPOD	1804 01 08 01 01 002 00DA	1

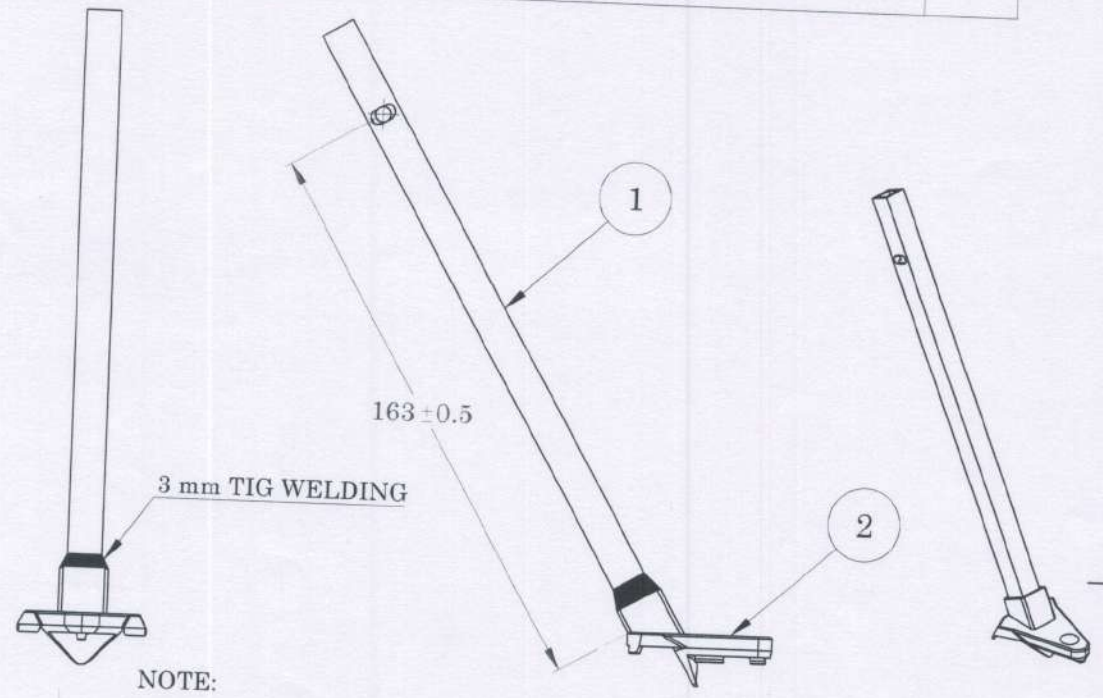

NOTE:
REMOVE ALL SHARP EDGES AND BURR.

Sr. No.	DATE	AUTHORITY	BRIEF RECORD	ZONE	CD	GO
					SIGN	

DRN: HARSH
 SIGN:
 DATE: 04/09/2020 CHECKED

MATERIAL: -----

APPD.
 DATE: 04/09/2020 FOR DIRECTOR

PROTECTIVE FINISH: -----

SEALED
 DATE:

SHEET SIZE: A4
 SCALE: 1:2
 EST. MASS approx. 118.0 gm

TITLE:
LOWER LEG RIGHT AND FOOT BIPOD WELDING ASSEMBLY

DESIGN AUTHORITY
 ARDE
 PUNE 411021

DRG No.	1 8 0 4	0 1	0 8	0 2	0 1	0 0 0	0 0 D A
	IC	SS	S	AA	A	C	SST

LMG PART No. DS CAT No. AHSP

240

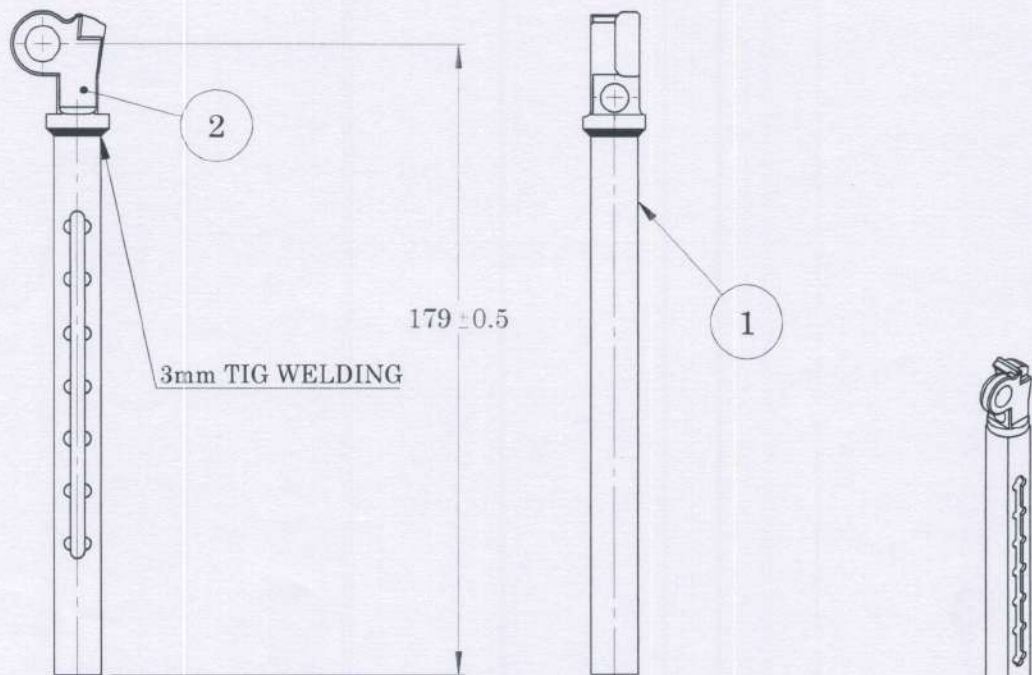
1	2	3	4
LSS V D 0 0	C 0 0 0	V 2 0	VV 2 0
C 8 0	SS 1 0	IC 4 0 8 1	DRG No.
GENERAL TOL. : FINE / MEDIUM / COARSE CLASS TO IS: 2102		DRG. CONVENTIONS CONFIRM TO INDIAN STANDARDS DIMENSIONS ARE IN mm UNLESS OTHERWISE STATED.	
A	DESCRIPTION		QTY.
ITEM NO.	PART NUMBER	DESCRIPTION	QTY.
1	UPPER LEG BIPOD	1804 01 08 01 02 001 00DA	1
2	LATCH BIPOD	1804 01 08 01 02 002 00DA	1
B			B
C	<p>NOTE: REMOVE ALL SHARP EDGES AND BURR.</p>		C
D	Sr. No.	DATE	AUTHORITY
E	BRIEF RECORD		ZONE
F	CD	GO	SIGN
E	DRN: HARSH SIGN: DATE:04/09/2020 CHECKED		MATERIAL: -----
E	APPD. DATE:04/09/2020 FOR DIRECTOR		PROTECTIVE FINISH: -----
E	SEALED DATE:		TITLE: UPPER LEG BIPOD AND LATCH BIPOD WELDING ASSEMBLY (RIGHT)
E	SHEET SIZE: A4 SCALE: 1:2	EST. MASS 123.3 gm	
E	DESIGN AUTHORITY ARDE PUNE 411021		
F	DRG No.	1 8 0 4	0 1
F	IC	SS	S AA A
F	LMG	PART No.	DS CAT No.
F			AHSP

233

DRG.No. 1804 0108 0100 002 00DA

GEN. TOL. FINE/MEDIUM/COARSE CLASS TO IS: 2102 ✓ DRG. CONVENTIONS CONFIRM TO INDIAN STD. DIMN. IN mm UNLESS OTHERWISE STATED

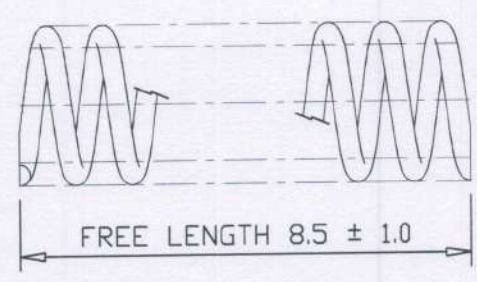
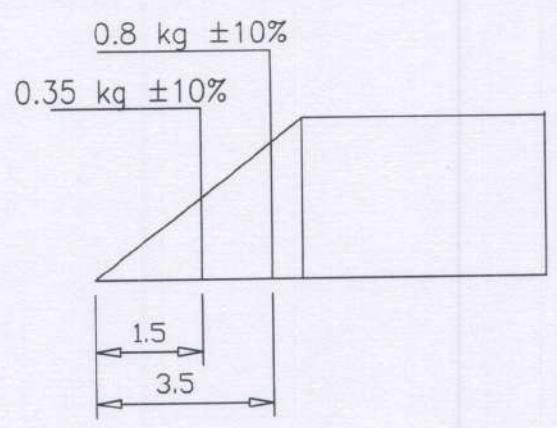

- NOTES :
1. TO BE STRESS RELIEVED
 2. WIRE DIA : $\phi 0.6$
 3. MEAN DIA : $\phi 4.9 \pm 0.2$
 4. NO. OF EFFECTIVE COILS: 5 Nos
 5. WOUND : LH OR RH
 6. CRAMP TEST : SPRING TO BE TESTED BEFORE GAUGING BY COMPRESSION TO SOLID LENGTH FOR A PERIOD OF 24 HRS AFTER WHICH IT MUST CONFIRM TO FREE LENGTH.
 7. ONE COIL OF EACH END TO BE CLOSED IN AND GROUND SQ. TO THE AXIS OF THE COIL, LEAVING 3/4 OF COIL AT EACH END NON EFFECTIVE.

Sr. No.	DATE	AUTHORITY	BRIEF RECORD	ZONE	CD	GO
					SIGN	
DRN.HARSH	DATE:04/09/2020	CHD.	MATERIAL : STEEL WIRE TO IS:4454 (PT I) 2001 DM			
APPD.	DATE	FOR DIRECTOR	PROTECTIVE FINISH :			
SEALED	DATE		PHOSPHATED TO SPECJSS-0465-01-1988 CLASS II OIL FINISH			
SCALE:- NTŞ	EST. MASS		TITLE :			
DESIGN AUTHORITY ARDE PUNE 411021			SPRING INNER BIPOD			

DRG.No. 1804 0108 0100 002 00DA

234

1	2	3	4															
LSS V D 0 0	C E 0 0	V 0 0	VV 1 0															
C 8 0	SS 1 0	CI 4 0 8 1	DRG No.															
A		A																
GENERAL TOL. : FINE / MEDIUM / COARSE CLASS TO IS: 2102		DRG. CONVENTIONS CONFIRM TO INDIAN STANDARDS DIMENSIONS ARE IN mm UNLESS OTHERWISE STATED.																
B			B															
C			C															
D	<p>NOTE:</p> <p>1.REMOVE ALL SHARP EDGES AND BURRS.</p> <p>2.HARDNESS: 410 TO 460 HV</p>		D															
E	<table border="1" style="width:100%; border-collapse: collapse;"> <tr> <th style="width:10%;">Sr. No.</th> <th style="width:15%;">DATE</th> <th style="width:20%;">AUTHORITY</th> <th style="width:35%;">BRIEF RECORD</th> <th style="width:10%;">ZONE</th> <th style="width:10%;">CD SIGN</th> <th style="width:10%;">GO SIGN</th> </tr> <tr> <td> </td> <td> </td> <td> </td> <td> </td> <td> </td> <td> </td> <td> </td> </tr> </table>	Sr. No.	DATE	AUTHORITY	BRIEF RECORD	ZONE	CD SIGN	GO SIGN								<p>DRN: HARSH SIGN: DATE:04/09/2020</p> <p>CHECKED</p> <p>MATERIAL: IS : 5517 1993 Gd 40Ni6Cr4Mo3-(En24)</p> <p>PROTECTIVE FINISH: NITRIDING DULL BLACK MATT FINSH AS PER MIL-S-6090 A COATING THICKNESS : 10-20 MICRONS</p> <p>TITLE: WASHER BIPOD</p>		E
Sr. No.	DATE	AUTHORITY	BRIEF RECORD	ZONE	CD SIGN	GO SIGN												
F	<p>DRG No. 1 8 0 4 0 1 0 8 0 1 0 0 0 0 3 0 0 D A</p> <p>IC SS S AA A C SST</p> <p>LMG PART No. DS CAT No. AHSP</p>		F															

249

1	2	3	4
LSS	C	V	VV
V	D	0	0
0	0	0	0
0	0	0	0
8	0	0	0
1	0	0	0
4	0	8	1

GENERAL TOL. : FINE / MEDIUM / COARSE DRG. CONVENTIONS CONFIRM TO INDIAN STANDARDS
 CLASS TO IS: 2102 DIMENSIONS ARE IN mm UNLESS OTHERWISE STATED.

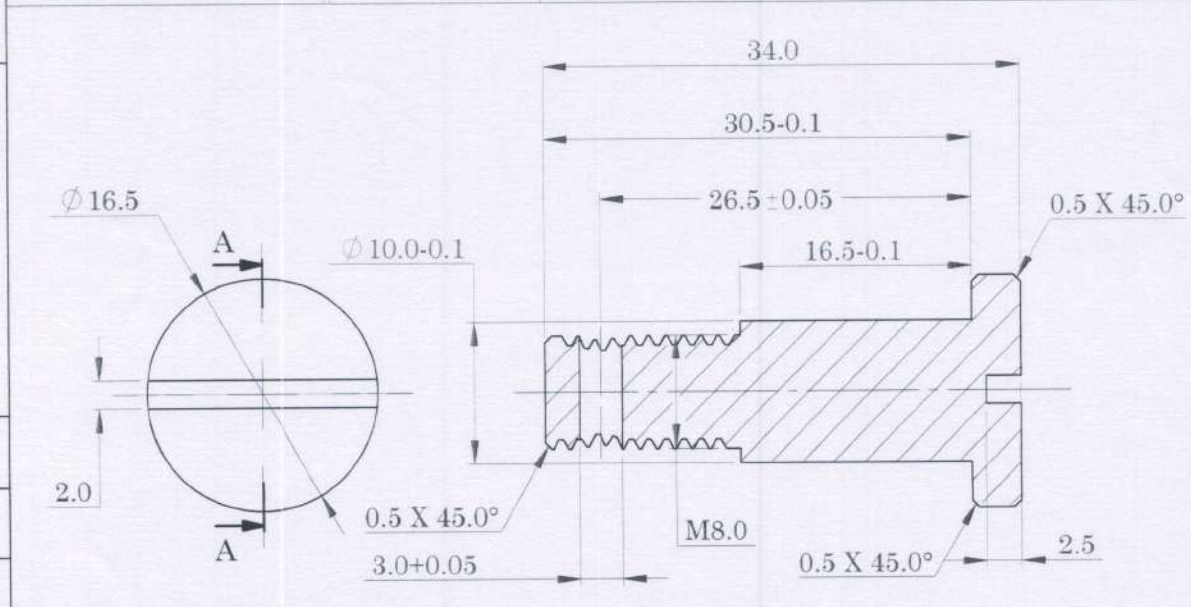

SECTION A-A

NOTE:
 1. REMOVE ALL SHARP EDGES AND BURRS.
 2. HARDNESS: 410 TO 460 HV.

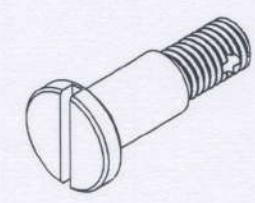

Sr. No.	DATE	AUTHORITY	BRIEF RECORD	ZONE	CD	GO
					SIGN	

DRN: HARSH SIGN: DATE: 04/09/2020	CHECKED	MATERIAL: IS : 5517 1993 Gd. 40Ni6Cr4Mo3 (En-24)
APPD. DATE: 04/09/2020 FOR DIRECTOR SEALED DATE:		PROTECTIVE FINISH: NIRIDING DULL BLACK MATT FINISH AS PER MIL-S-6090 A COATING THICKNESS : 10-20 MICRONS
SHEET SIZE: A4 SCALE: 2:1	EST. MASS approx. 20.4 gm	TITLE: PIN TORSION BIPOD
DESIGN AUTHORITY ARDE PUNE 411021		

DRG No.	1	8	0	4	0	1	0	8	0	0	0	0	0	3	0	0	D	A
	IC				SS		S		AA		A		C		SST			
LMG	PART No.				DS CAT No.				AHSP									

251

DRG.No. 18040108000000500DA

GEN. TOL. FINE/MEDIUM/COARSE
CLASS TO IS: 2102

DRG. CONVENTIONS CONFIRM TO INDIAN STD.
DIMN. IN mm UNLESS OTHERWISE STATED

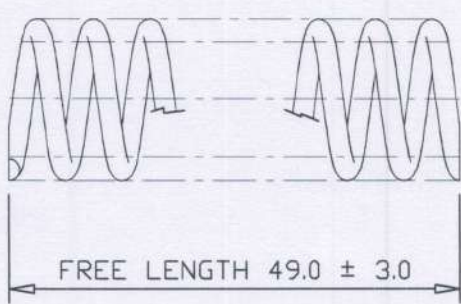
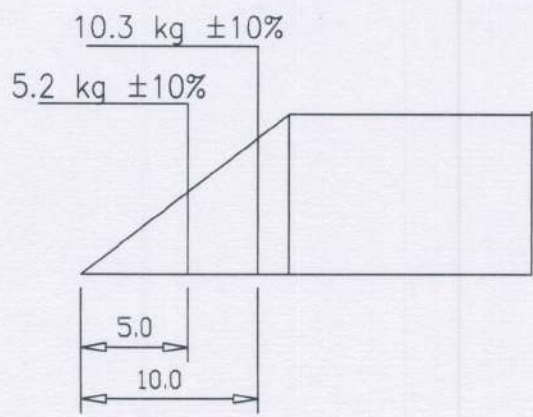

- NOTES :
1. TO BE STRESS RELIEVED
 2. WIRE DIA : $\phi 1.5$
 3. MEAN DIA : $\phi 6.3 \pm 0.2$
 4. NO. OF EFFECTIVE COILS: 18 Nos
 5. WOUND : LH OR RH
 6. CRAMP TEST : SPRING TO BE TESTED BEFORE GAUGING BY COMPRESSION TO SOLID LENGTH FOR A PERIOD OF 24 HRS AFTER WHICH IT MUST CONFIRM TO FREE LENGTH.
 7. ONE COIL OF EACH END TO BE CLOSED IN AND GROUND SQ. TO THE AXIS OF THE COIL, LEAVING 3/4 OF COIL AT EACH END NON EFFECTIVE.

E	Sr. No.	DATE	AUTHORITY	BRIEF RECORD	ZONE	CD	GO
	DRN.HARSH		CHD.	MATERIAL : STEEL WIRE TO IS:4454 (PT I) 2001 DM		SIGN	
	DATE:04/09/2020						
	APPD. DATE		FOR DIRECTOR	PROTECTIVE FINISH :			
SEALED DATE			PHOSPHATED TO SPEC.JSS-0465-01-1988 CLASS II OIL FINISH				
F	SCALE:-NTS		EST. MASS	TITLE :			
	DESIGN AUTHORITY ARDE PUNE 411021			SPRING BIPOD			
	DRG.No.	1	8	0	4	0	1

DRG.No. 18040108000000500DA