

**RESTRICTED  
(DRAFT/PROVISIONAL)  
QUALITY ASSURANCE PLAN**

**FOR**

**(BARRIER-TAPER- RH)**

**DRG.NO.V572.0175.7022**

**(LF NO: 6206801831)**

**No.HVF/T-72/QAP/BARRIER-TAPER- RH/245469-00**

**ISSUE No: 00**

**DATE: MAR-2023**

**QUALITY ASSURANCE (RIG-OE)**

**HEAVY VEHICLES FACTORY**

**AVADI CHENNAI – 600 054**

**QUALITY ASSURANCE PLAN (QAP)**

**FOR**

**BARRIER-TAPER- RH**

**DRG. NO. V572.0175.7022**

PREPARED BY

  
(C.NANDA KUMAR)  
JWM/QA (RIG-GA&OH)

REVIEWED BY

  
(AWNEESH YADAV)  
JWM/QA (RIG-OE/TA)

APPROVED BY

  
(NEERAJ KUMAR)  
DGM/QA-RIG-(OE)

ISSUED BY

QUALITY ASSURANCE (RIG- OE)  
HEAVY VEHICLES FACTORY  
AVADI CHENNAI – 600 054

SI. No	CONTENTS	PAGE .No.
1.	IMPORTANT NOTES	4
2.	INTRODUCTION	4
3.	AIM	4
4.	SCOPE	5
5.	DOCUMENTS	5
6.	ITEM USED ON	6
7.	LIST OF DRAWINGS	6
8.	BILL OF MATERIAL	6
9.	CONDITIONS OF USE/ STORAGE INSTRUCTIONS	6
10.	SAMPLING PLAN	7
11.	VISUAL INSPECTION	7
12.	DIMENSIONAL CHECKS	8
13.	MATERIAL CHECKS	8
14.	ACCEPTANCE / PERFORMANCE TESTS	9
15.	FITMENT AND PERFORMANCE TEST	9
16.	INTERCHANGEABILITY	10
17.	CALIBRATION CHECKS	10
18.	MARKING/IDENTIFICATION	10
19.	PRESERVATION CHECK	10
20.	PACKING CHECK	10
21.	DOCUMENTATION	11
22.	REFERENCE	11
23.	ANNEXURE-A	12
24.	FIGURE	13
25.	APPENDIX-A	14

## 1. IMPORTANT NOTES

### **Note-1**

This is only a provisional and will be amended from time to time according to the requirement. No addition, deletion and reproduction will be done without permission of The Chief General Manager, Heavy Vehicles Factory, Avadi, Chennai – 54.

### **Note-2**

Any instruction contained in this does not prejudice the terms and conditions of the contract what so ever. In case of any contradiction between the contents of this QAP and the clause in the contract, the latter will prevail.

### **Note-3**

The stores should be manufactured strictly only as per the drawings supplied by the Inspection Authority and not as per the samples, if any received by the manufacturer for guidance purpose.

### **Note-4**

Any amendment issued by the Inspection Authority shall be incorporated in the QAP and the records for the amendments carried out should be maintained as per the Performa at Appendix-"A".

### **Note-5**

In case of any contradiction between the contents of this QAP and drawings/specifications/GOST issued along with the contract, the latter only will prevail.

## 2. INTRODUCTION

1. This quality plan lays down the inspection and testing procedure to be carried out on the component **BARRIER-TAPER- RH TO DRG.NO V572.0175.7022** being procured indigenously. This is prepared, based on the acceptance standards and inspection parameters laid down in collaborators documents and on the inspection test standards followed in respect of similar indigenous items.
2. This QAP is the property of Government of India and is liable for amendments as and when required. The Chief General Manager, Heavy Vehicles Factory, Avadi, Chennai – 600 054, is the inspecting Authority for this assembly. Any query / clarification on the content of this QAP shall be referred to this Factory. Any departure from these instructions is allowed only after written approval from the above authority. Notwithstanding the tests indicated in this QAP, the inspecting Officer has the right to carry out any test to check conformance to the paper particulars quoted in the Supply Order, which he may consider necessary to satisfy himself about the stores which he has to accept.

## 3. AIM

The QAP is aimed at standardizing the Inspection procedure and acceptance norm for **BARRIER-TAPER- RH TO DRG.NO:V572.0175.7022**.

It also aims at giving adequate information to the manufacturer on the quality requirements so that the required quality control methods are established. This is also meant to guide authorized Inspection Officer in his routine inspection and to set out main points to which his attention must be drawn to ensure that the accepted stores meet the stipulated standards.

#### **4. SCOPE:**

This QAP outlines in general terms, the checks and methods to be used during inspection of **BARRIER-TAPER- RH TO DRG.NO.V572.0175.7022** including the technical requirements of the drawings. The recommended Quality Plan stipulated herein is mandatory and should be strictly adhered to.

For inspection purpose, only the latest issue of this QAP will be made applicable and copies of this QAP can be obtained from the issuing authority i.e. The Chief General Manager, Heavy Vehicles Factory, Avadi, and Chennai.

#### **Note:**

- i. Tender enquiry (TE) and supply order (S.O) will be issued with QAP stating that inspection will be done as per QAP.
- ii. In case of TE, It is responsibility of the vendor to obtain the copy of QAP and give the statement of compliance that vendor will abide by the QAP in case supply order is placed.
- iii. In case of S.O, it is the responsible of the vendor to obtained copy of QAP and give the statement of compliance that the vendor will follow QAP. However, GM/HVF reserves the right to revise/update the QAP from time to time.

#### **5. DOCUMENTS:**

- a) On placement of firm supply order, One set of relevant technical documents for manufacturing (includes details about material, casting/forging, machining, heat processes, etc. and up to final inspection) the components like GOST/Drawing/Specification, Technical data book, process sheet etc., and technical instructions on the subject item is to be obtained by the contractor from AHSP through DDO/HVF.
- b) Any clarification required on these documents to be obtained from the Inspecting Authority i.e. The Chief General Manager, Heavy Vehicles Factory, Avadi, Chennai – 600 054. Equivalentents to the collaborators specifications and standards will be decided only by the Inspecting Authority and should not be unilaterally decided. For any change in the specifications, standards or written approval, any alterations in specification can be affected and not otherwise.
- c) The process instruction sheets supplied by the collaborators are available with the Authority Holding Sealed Particulars, i.e. The Controllerate of Quality Assurance (Heavy Vehicles), Avadi, Chennai for the reference. The relevant process sheets may be studied at the premises of the AHSP after obtaining necessary permission.

d) The supplier after scrutiny of the concerned process sheets and connected paper particulars should establish the necessary production and inspection facilities. Particularly the inspection test rigs, stands, fixtures, template, gauges etc., should be provided as recommended in these process sheets. If process sheet / Process Book is not available the details particulars/parameters available in the drawings to be strictly adhered.

**6. ITEM USED ON:**

- 1. V572.0175.0118 -
- 2. V572.0175.0318 -
- 3. V572.0175.0618 -

**7. LIST OF DRAWINGS:**

SI. NO.	DRG. NO	NOMENCLATURE	REMARKS
1	V572.0175.7022	BARRIER-TAPER-RH	-

**8. BILL OF MATERIALS: (Individual items as mentioned in table to Para 7)**

SI. NO	DRG. NO	NOMENCLATURE	MATERIAL SPECIFICATIONS	Qty
1	V572.0175.7022	BARRIER-TAPER-RH	STEEL TO SPEC IS: 2062 Fe 410 WA	1

**Note:** Vendor / Contractor may use approved alternate material, if any specified in drawing/specification.\* also refer Para no: 13.

**9. CONDITIONS OF USE / STORAGE INSTRUCTIONS**

This assembly / item should be properly packed to protect from transit / handling damage and influence of atmospheric precipitations. In addition, the following parameters should be ensured:

- (a) The threaded parts if any should be covered with suitable plastic caps to prevent damages.
- (b) If the item consists of assemblies, each assembly should be packed separately.
- (c) The stores are to be suitably covered for preventing ingress of dust and Dirt/entry of sunlight / moisture.
- (d) The packaging slip shall contains
  - (i) Certificate of testing- NABL Certificate.
  - (ii) Guarantee/ Warranty Certificate.
  - (iii) Service and maintenance instructions.
  - (iv) Delivery Slip with Inspector's Acceptance Mark.
  - (v) Undertaking letter / Certificate of conformance (As applicable).

- (e) The stores are not permitted to be stored together with oils. Petrol, acids, alkaline and other substances to avoid damage to the metal / rubber components.

#### 10. SAMPLING PLAN:

Sl. No.	Sampling Plan	Pilot *	Bulk
	<b>Acceptance test ( as below)</b>		
(i)	Visual Inspection	100%	100%
(ii)	Dimensional Inspection (Including hardness)	100%	General Inspection level III, single sampling, Normal Inspection, AQL 2.5 of IS 2500 (Part-I)-2000
(iii)	Material Inspection (including Chemical, Mechanical & Physical properties)	1 No	1 No. for each batch of raw material or heat treatment lot /as required by specifications and as required by HVF for confirmation of material.
(iv)	Pressure testing	----	-----
(v)	Machining/Fitment/ Performance trial on higher assembly / Tank	----	-----
vi)	Interchangeability Test	----	-----
vii)	Calibration Reports/Certificates of Test stand/Jigs/ Equipment's/Fixtures/ Gauges/Mandrels/etc.	100 %	100 %
viii)	Marking/Identification	100%	100%
ix)	Packing/Preservation	100%	100%

#### Note:-

\* This clause is applicable if mentioned in supply order or project sanction order.

A New (First time supplier of this item) supplier should obtain clearance from HVF for bulk production which will be issued only after inspection/evaluation of pilot samples by HVF.

#### 11. VISUAL INSPECTION [Sampling plan as per Para- 10 (i)]

The stores are to be visually examined on 100 % of pilot /bulk and same should be free from any defects and all the finishing requirements shall satisfy as indicated in technical conditions of the assembly / component drawing.

The components shall be checked for the following and should be free from the defects:

- Defects in construction
- Cracks/Dents/Scratches
- Fitment of all components
- Presence of foreign particles
- Moisture and dust
- Corrosion of metal parts
- Mechanical imperfections & distortion
- Any form of deterioration of material and finishing.

Packing and preservation should be ensured as per drawings/relevant TY specification (To be ensured on receipt at consignee end).

## **12. DIMENSIONAL CHECK [Sampling plan as per Para- 10(ii)]**

The dimensions including geometrical parameters of individual component, sub assembly and major assembly shall be checked and ensured as per respective drawing. Dimensional check should be carried out as per sampling plan. However, the inspecting authority/rep. may at his discretion, tighten the inspection level and acceptance quality level on the critical items and adopt check point during manufacture.

### **12.1 BARRIER-TAPER- RH TO DRG.NO:V572.0175.7022**

1. All dimensions including geometrical parameters shall be confirmed as per drawing/specification.
2. Surface finish/Roughness should be confirmed as per drawing and specification.
3. For admissible alternate method for manufacture in dimensions/material if any, refer drawing/GOST/specification.

## **13) MATERIAL CHECKS [SAMPLING PLAN AS PARA – 10 (iii)].**

Material specimen /test bars of the components shall be in conformity as per the material mentioned in the relevant documents/drawing. NABL test reports for all the parameters as per relevant specifications to be submitted. Test samples to be submitted by the vendor to HVF, if required. The material check will be carried out as per sampling plan. \*However, if the manufacturer proposes any alternative material at the stage of tender enquiry, the same has to be approved and a written concurrence should be obtained from AHSP through DDO/HVF, before usage of such materials.



**13.1 BARRIER-TAPER- RH TO DRG.NO:V572.0175.7022**

- a) The component should be manufactured from STEEL GRADE Fe 410 WA TO IS: 2062.
- b) **Chemical properties:** As per STEEL GRADE Fe 410 WA TO IS: 2062.

CONTENT OF ELEMENTS %					
C	Si	Mn	Carbon Equivalent CE	S	P
Max					
0.23	0.40	1.50	0.42	0.050	0.050

**Note:** For mass fraction of other elements refer IS: 2062.

- c) **Mechanical properties:** As per STEEL GRADE Fe 410 WA TO IS: 2062.

Tensile Strength Mpa, Min	Yield Stress Mpa, Min			% Elongation at Gauge Length $5.65\sqrt{S_0}$ , min	Internal Diameter of Bend.
	<20 mm	20-40 mm	>40 mm		
410	250	240	230	23	3t

**Note:** For details of other parameters & properties refer IS: 2062.

**14) PERFORMANCES / ACCEPTANCE TEST: BARRIER-TAPER- RH TO DRG.NO:V572.0175.7022**

1. (a) STEEL TO SPEC IS : 2062 Fe 410 WA  
(b) HOT ROLLED UNEQUAL LEG ANGLE TO IS: 808 (PART VI) ISA 10075.
2. REMOVE SCALES AND BURRS AFTER MACHINING.
3. RED-OXIDE PAINTING IS TO BE DONE TO SPECN. JSS: 3-47-13 CQAEM/SS/133 SHADE CODE-446 FOR PRIMER FINISH (or) IS:2074-1992.

**15) FITMENT AND PERFORMANCE TEST:**

- a. Pilot samples should be checked for fitment and Performance test to ascertain the efficacy of the system under different operating conditions by fitting in higher assembly and repeating it for functional checks, wherever required.
- b. Items of Bulk supplies may be subjected to performance trial in tank in case of repeated failure/defects during exploitation.

**16) INTERCHANGEABILITY:**

The assemblies/component should be interchangeable component wise and assembly wise, except the Component are to be supplied as a set and to be assembled selectively as per sampling plan.

**17) CALIBRATION CHECKS  
(TEST STANDS/JIGS/FIXTURES/GAUGES/INSTRUMENTS):**

The supplier / Contractor should have suitable Instruments, Test Stand, jigs, fixture, mandrels and gauges to carry out quality checks, to ensure conformance of components/assembly as per drawing and Specification /T.R points.

The supplier/contractor should submit calibration reports for instruments/fixtures/gauges/mandrels etc., which are used during process of inspection activities.

**18) MARKING / IDENTIFICATION.**

Marking of the items is to be carried out as called for in the relevant drawing, drawing/T.R points.

Inscription if any on the components is to be carried out as called for in the drawing/T.R points. Unless otherwise specified in the drawing/ specification, marking should not be carried out over the components.

For traceability, marking of part No., Manufacturer name, supply order No, Serial No/Qty., batch No. and manufacture date & year are to be carried out. Suitable method can be adopted, provided that the above parameters are legible and considering the parameters mentioned in the drawing and specification.

**19) PRESERVATION CHECK**

- a) Preservative coatings are to be strictly adhered to as called for in the drawing. However, equivalent BIS Standards can also be followed, subject to the thickness of the coating/preservative is maintained as per the drawing/specification.
- b) Other preservations as necessary to prevent damages due to moisture and dust during process, storage and transit are to be carried out. Conventional Methods can also be resorted to.

**20) PACKING CHECK**

Components / Assemblies are to be packed separately to avoid damages during transit / handling of the same. Part No. and No. of sets are to be marked on the packing.

Packing and preservation should be ensured as per drawings/relevant TY specification (To be ensured on receipt at consignee end).

Finished products shall be wrapped / packed using black and opaque polyethylene sheet or bags.

## **21) DOCUMENTATION**

1. Firm has to maintain all the documents as per QAP with respect to the SI.No.to have traceability.
2. Vendor has to submit Bill of materials, Material test reports, Class 'C' /Endurance test reports (wherever specified in drawing/TY specification/QAP) and Complete PIR (pre-inspection report)at the time of offering the item for inspection. HVF will commence inspection only after scrutiny of these documents.
3. The testing/inspection responsibility to test all the parameters as per QAP and drawing specifications as mentioned in Annexure -A (enclosed).
4. Pre inspection reports (PIR) of firm like, 1. Chemical analysis (NABL Certificate), 2.Mechanical properties (NABL Certificate), 3. Pre-forming process, 4. Coating certification (Wherever applicable), 5. Calibration reports of instruments and 6. 100 % Dimensional inspection reports and other relevant reports for acceptance of the item as specified in GOST/ Specification / drawings etc., are to be submitted.

## **22) REFERENCE:**

- a) Drawing No: V572.0175.7022.
- b) Material specification as per drawing:  
STEEL TO SPEC IS: 2062 Fe 410 WA.
- c) Specification: IS: 2062, IS: 808, IS: 2074-1992.

Sl. NO.	CATEGORY	ASSEMBLY/ SUB ASSEMBLY	TESTS/ INSPECTION PARAMETERS	STANDARDS TO BE REFERRED	ACCEPTANCE CRITERIA	INSPECTION RESPONSIBILITY			REMARKS
						Firm	HVF	DGOA	
1	BARRIER- TAPER- RH TO DRG. NO V572.0175.7022	Pre inspection reports (PIR) of firm	Firm has to produce all the document as per QAP	As per the relevant drawing and QAP.21(4)	Confirm to drawing and QAP as per bill of material	P	V	R	100% by firm/ vendor.
2		Bill of material (BOM)	Firm has to prepare the BOM as per QAP	Refer QAP Para no: 8 or item list.	Confirm to QAP	P	V	R	100% by firm/ vendor.
3		Dimensional checks	Dimensions as per the drawing	Refer drawing / QAP Para no: 12.1	Confirm to drawing and QAP	P	W/P	R	100% by firm/ vendor SP followed by HVF
4		Material tests	Chemical composition & Mechanical / Physical Properties	As per-IS: 2062.	All the values to confirm with QAP (Para no:13.1 (a), (b)& (c))	P	W/V	R	100% by firm/ vendor SP followed by HVF
5		Coating Checks	Coating (Red-oxide painting)	Refer QAP Para no:14(3)	Confirm to QAP Para no: 14(3)	P	W/V	R	SP followed by HVF.
6		Marking / traceability	Marking / traceability	Refer QAP Para no: 18	Confirm to QAP Para no: 18.	P	V	R	100% by firm/ vendor.
7		Preservation & packing	Preservation & packing	Refer QAP Para no 19 & 20	Confirm to QAP Para no 19 & 20	P	V	R	100% by firm/ vendor.

**Note:**

For conformity of the items (Chemical/Physical/Mechanical properties).

1. One sample per heat / batch shall be tested under NABL Lab/Govt. Approved lab by firm. In case of non-compliance to standards entire lot shall be rejected or not to use in production further.
2. For cross conformation of material, manufacturer has to submit test sample pieces for the items used / test slab and button for rubber items / HVF will draw samples from supplied lot for Witnessing (W) at HVF premises. In case of non-compliance to standards entire lot will be rejected.
3. All other relevant tests as specified in GOST/ Specification/ Drawing is to be carried out by firm and to be confirmed.

**P- Perform****W- Witness****V- Verify****R- Review****SP- Sampling Plan**

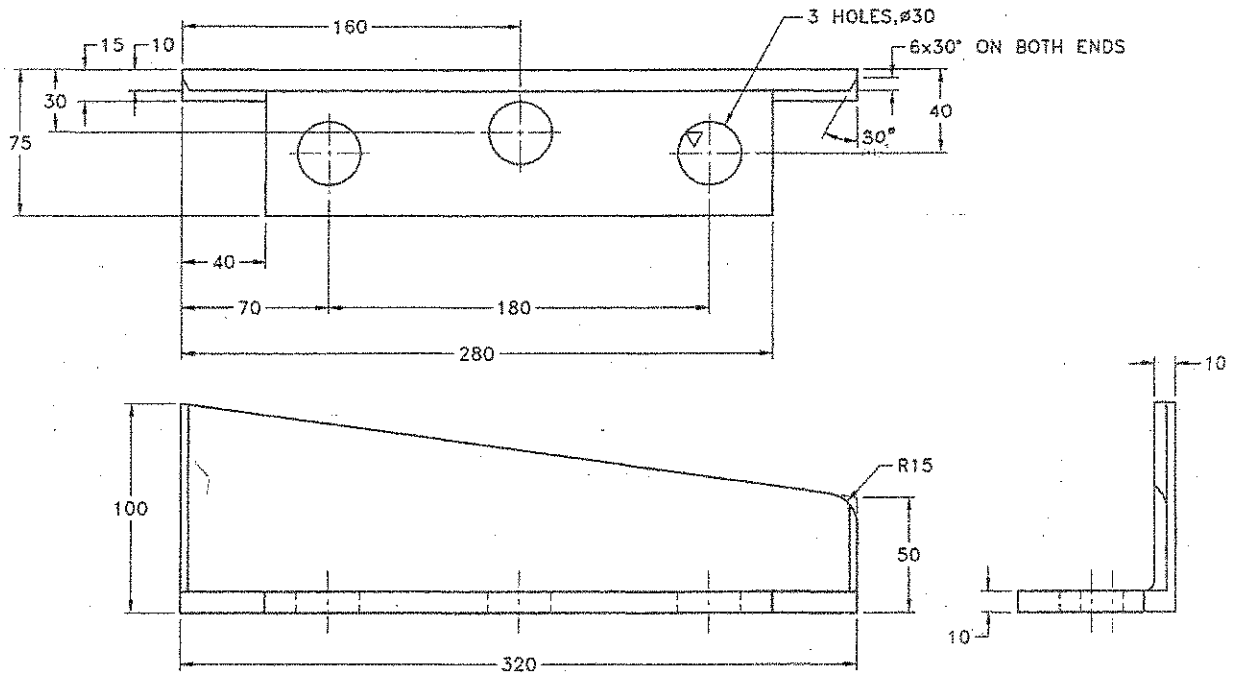

**FIG: BARRIER-TAPER- RH TO DRG.NO.V572.0175.7022.**  
 (For reference only)

