

ANGLE MAY BE ADJUSTED ON ASSY FOR TRIGGER PULL

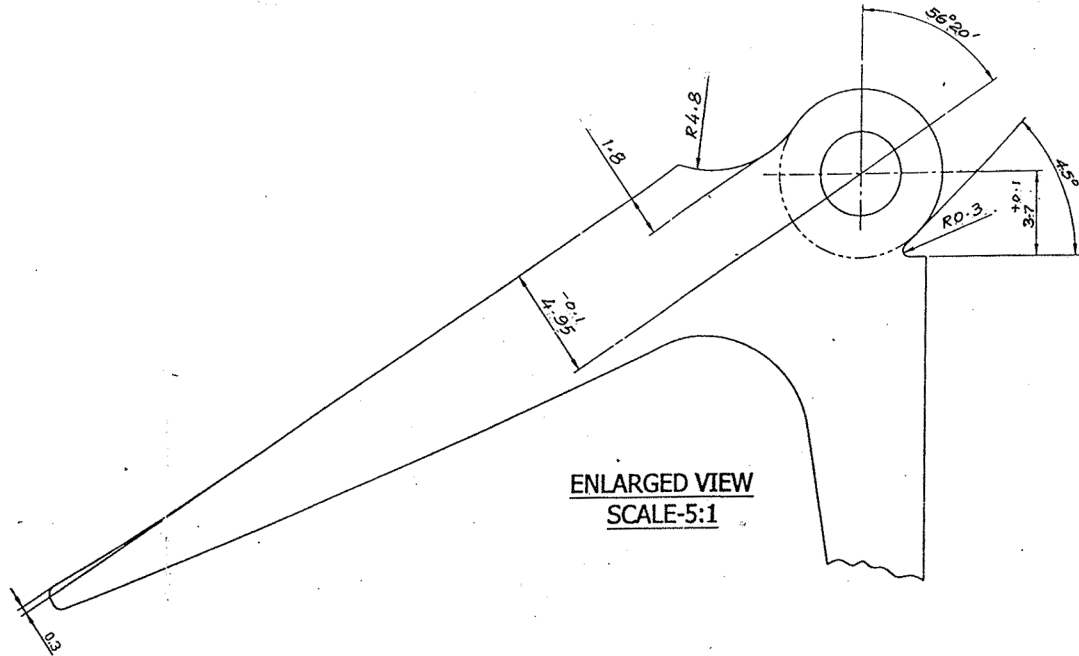
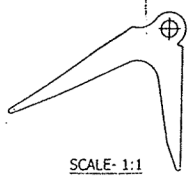

ENLARGED VIEW
SCALE-5:1

ALT. MATL. FOR MIM ROUTE ONLY.
 MATL. SPECN.: MIM 4650
 C - 0.3 TO 0.6 Si - 0.5 MAX.
 Ni - 1.5 TO 2.5 Mn - 0.3 MAX.
 Cr - 0.5 MAX. P - 0.03 MAX.
 Mo - 0.5 MAX. Fe - BALANCE.

NOTE :- HARDENED AND TEMPERED TO GIVE A V.P.N 400-450 ON WORKING FACES AT ENDS OF BOTH SHORT AND LONG ARMS (APPROX. 5/8" FROM BENDS)

MATERIAL :- STEEL BS 970 PT.1-1983 GR.060 A-67 OR GR.080 A-67

PROTECTIVE FINISH :- PHOSPHATE TO SPECN.WPN/GEN/3 CLASS-1 SPIRIT STAIN BLACK OIL FINISH

REF:- DRG.PREPARED AS PER G-1043

DIMENSIONS ARE IN mm.
 INFORMATION MARKED THIS '†' TO BE MARKED ON
 UNTOLERATED DIMENSIONS AS PER IS. 2102 (MEDIUM)

PART NO.	DESCRIPTIONS	NO OFF	MATERIAL	TREATMENT	REMARKS
----------	--------------	--------	----------	-----------	---------

8996/14/000/01 Dt. 29.5.09 8996/14/000/04 Dt. 1.04.08	SIGNATURE & DATE: TRACED DRAWN: <i>[Signature]</i> CHECKED: <i>[Signature]</i> VOIC/DDO: V. Vallurudhu PROD. OFFICER DIV. OFFICER DDO	SUB: SEAR FOR: OF: .315" SPORTING RIFLE DES. REF. NO: SP-60 DRG. NO: 29P-0060*2	SCALE 2:1, 5:1 STORE DRG.NO. OPERATION NO. SHEETS: SHEET NO:
	APPROVED ON:	ORDNANCE FACTORY TIRUCHIRAPALLI-16.	
	AMENDMENTS		
	SIG. & DATE		