

DRAWING NO.
175.45.023-1/F

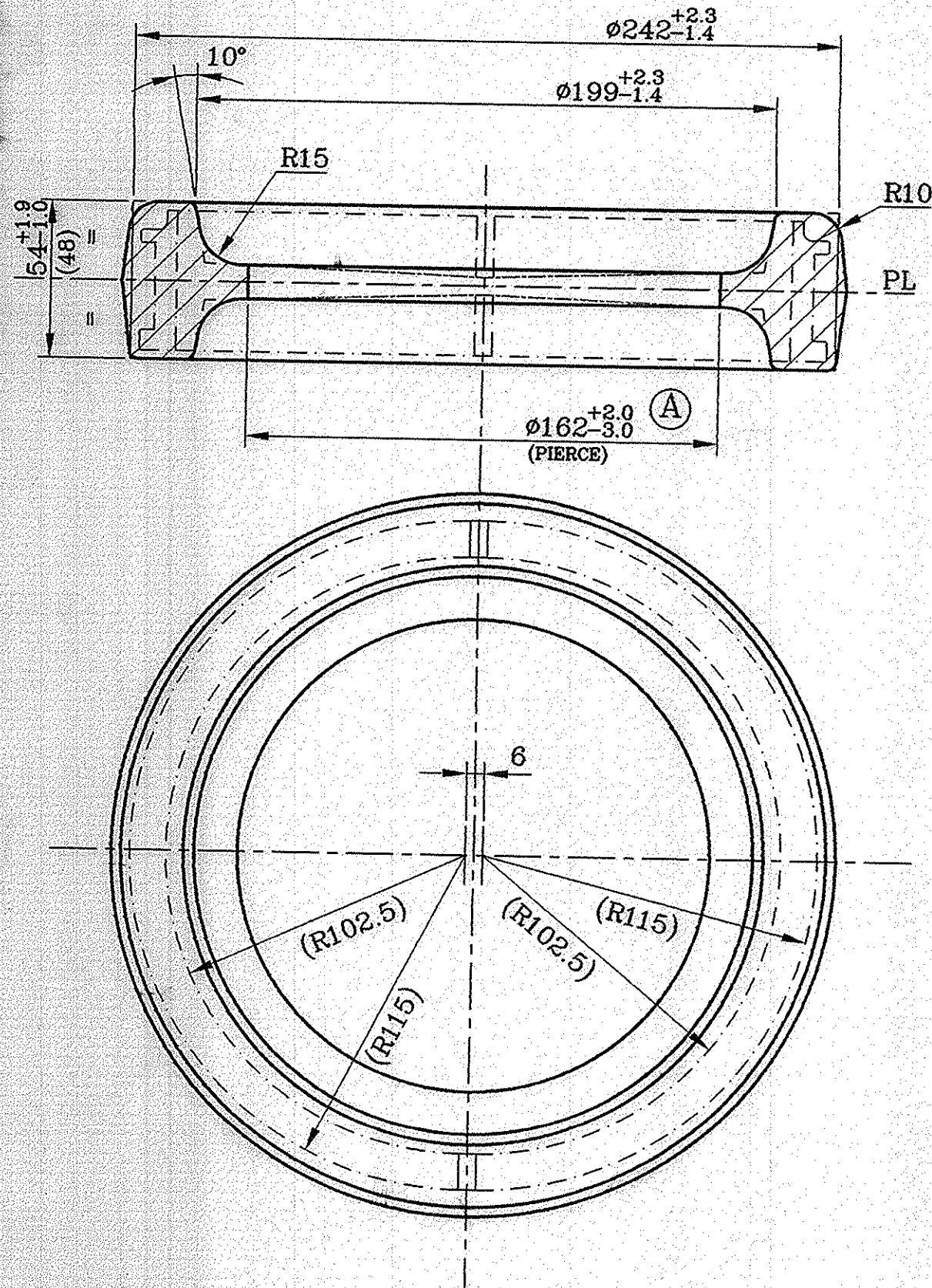

TECHNICAL REQUIREMENTS.

01. HEAT TREAT.: DIA.OF IND. \geq 3.8 MM.
02. DE-SCALE (SHOT BLAST)
03. SURFACE DEFECTS AND SCALE PITS UPTO 0.5 OF ACTUAL ALLOWANCE ARE ALLOWED.
04. MISMATCH SHOULD NOT EXCEED 1.1 MM
05. RESIDUAL FIN SHOULD NOT EXCEED 1.3 MM
06. BUCKLING SHOULD NOT EXCEED 1.2 MM
07. UNSPECIFIED DRAFTS 7°
08. UNSPECIFIED RADII R.3.0 MM
09. MARK PART NO.
10. FOLDING OF FIN ALLOWED IN PIERCED HOLE BRACKETS.
11. MACHINING DIMENSIONS ARE SHOWN IN BRACKETS.
12. UNTOLERANCED DIMENSIONS ARE FOR CONSTRUCTION.
13. ECCENTRICITY OF PIERCED HOLE SHOULD NOT EXCEED 2.0 MM.
14. PAINT RED OXIDE.

MODIFICATIONS & ADDITIONS

ISSUE	MODIFICATIONS & 'N' OF 'A'	SIGN.
A	PIERCING ϕ 162.0 WAS ϕ 180.0	
B	REDRAWN	<i>[Signature]</i>

NOTES:-

1. FORGING IS COMMON FOR 175.45.024-1/F
2. EACH FORGING CATERS FOR TWO COMPONENTS 175.45.023-1/F,BUSHING UPPER AND 175.45.024-1/F,BUSHING LOWER

TOOL NO.	TOOL DESIGNATION	MACHINE	REMARKS
20096	PIERCING TOOL	600 T	
20095	TRIMMING TOOL	600 T	
20094	STAMPING DIES	DG-13	

MATERIAL	FORGING WT.	SCALE	
STEEL 38XC GOST:4543-71	7.85 KGS		
ALT. MATERIAL	HAMMER	SCALE	
	DG-13	1:2	
DRAWN	CHECKED	APPROVED	AUTHD.
<i>[Signature]</i> 5/6/10	<i>[Signature]</i> 5/6/10	<i>[Signature]</i>	<i>[Signature]</i> 29/10/10
DRAWING NO. 175.45.023-1/F			
NOMENCLATURE: BUSHING,UPPER			
HEAVY VEHICLES FACTORY AVADI,CHENNAI			