

TECHNICAL REQUIREMENTS.

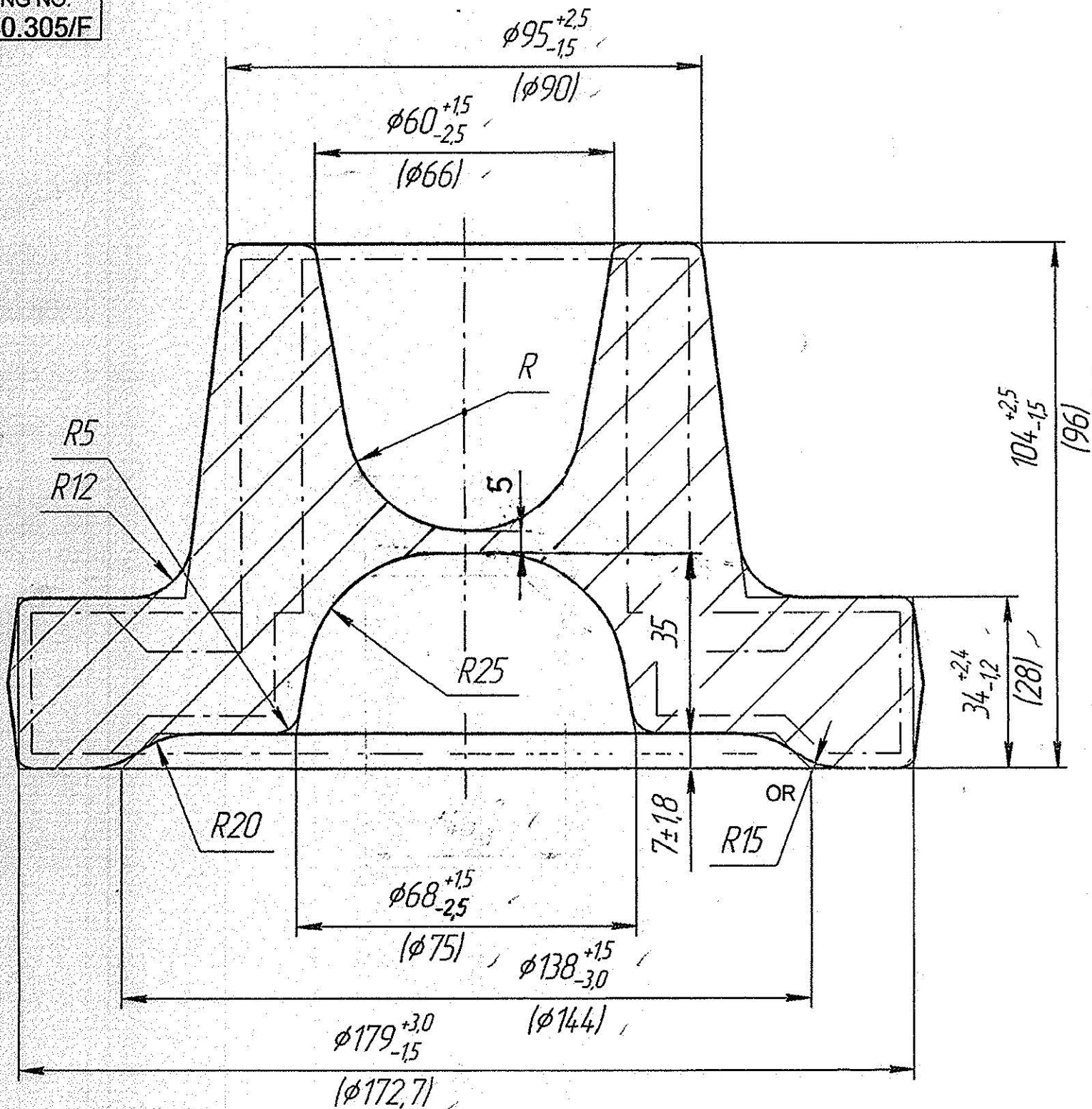

01. 207...269 HB.
02. ALTERNATIVE MATERIAL IS STEEL 20X2H4A-W GOST 4543-71
03. BURRS ON THE PERIMETER OF CUT ARE ALLOWED UPTO MAX.1.5 MM. CONTINUOUS BURIN HOLE IS ALLOWED.
04. SHIFT ALONG THE PARTING OF DIE IS ALLOWED UPTO 1.2 MM MAX.
05. NON-FLATNESS IS ALLOWED UPTO 1.0 MM MAX.
06. MIS-ALIGNMENT OF DIA 40 WITH RESPECT TO DIA.60 IS ALLOWED UPTO 3.0 MM MAX.
07. SURFACE DEFECTS SUCH AS DENTS DUE TO SCALES AND BURRS AS WELL AS CHIPPING OR FINISHING OF DEFECTS IN DEPTH MAX.50% OF ACTUAL ONE SIDE MACHINING ALLOWANCE MAY BE ALLOWED.
08. IT IS ALLOWED TO MARK PART NO.
09. STAMPING DRAFTS - 7°
10. UNSPECIFIED FILLET RADII - R 3.0 MM.
11. DIMENSIONS IN BRACKETS ARE FOR MACHINING.
12. DIMENSIONS WITHOUT TOLERANCES ARE FOR MAKING DIE.
13. DE-SCALES (SHOT BLASTING.)
14. FORGING II CLASS, GROUP OF STEEL M2, CATEGORY OF COMPLEXITY C3, GOST 7505-89.
15. PAINT RED OXIDE.

T 90

MATERIAL	FORGING WT.	
20X2H4A GOST 4543-71	9.20 KGS	
ALT. MATERIAL	HAMMER	SCALE
20X2H4A-W GOST 4543-71	DG-6	NTS
DRAWN	CHECKED	APPROVED
L. Ruff 13/19/03		
DRAWING NO.	172.40.305/F	
NOMENCLATURE:	SUN GEAR II PLANETARY GEAR SET.	
HEAVY VEHICLES FACTORY AVADI, CHENNAI		
ISS.	MODIFICATION	DATE

A PIERCING DIA, 40 mm DELETED.

L. Ruff
13/19/03
25/11