

DRAWING NO.

172-43-005/F

ISSUE	MOD. & ADDITIONS.	SIG.
A	45°, 30, R15 & R30 DELETED.	15
	DIMN 69, R12, R50, R125 & 15° DRAFT ADDED. (TO AVOID CORNER UNFILLING)	24/12/92
B	TOTAL LENGTH DIMNS 474 ^{+5.6} WAS 464 ^{+5.6} FLANG THICKNESS 120 DIMN. WAS 110 60 DIMN. WAS 55 74 DIMN. WAS 69 JNM/FS INSTRUCTION DT. 12.3.2000	14.3.2K

REF: 07271/04/QA (OH)/
99-2000 DT 25-1-2K

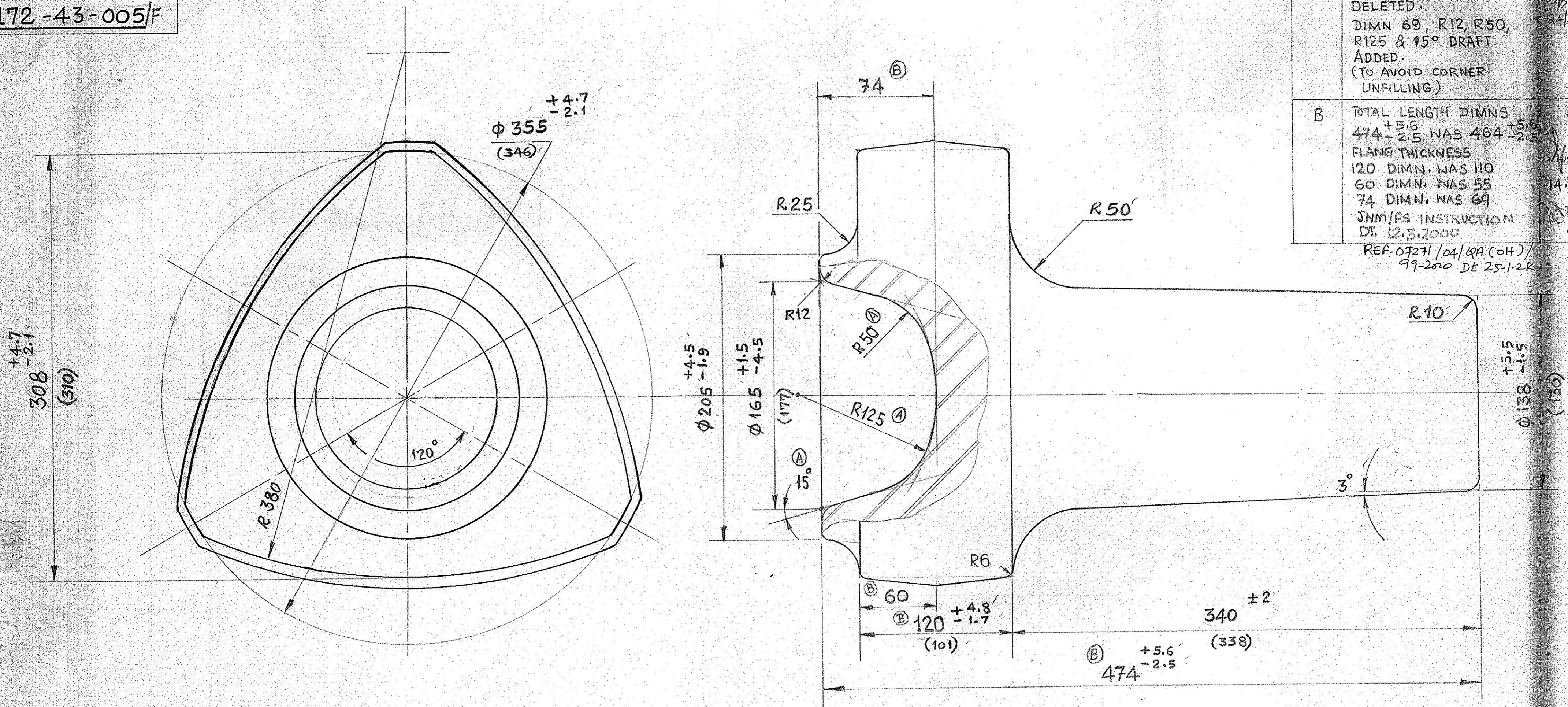

TECHNICAL REQUIREMENTS.

1. STAMP IDENTIFICATION MARK.
2. HEAT TREAT. DIA. OF INDENTATION = $\nabla 3.8$
3. DESCALE - SHOT BLAST.
4. SURFACE DEFECTS AND PITS FROM SCALES UPTO 0.5 OF ACTUAL MACHINING ALLOWANCE IS ALLOWED.
5. MISMATCH UPTO 2.2 mm IS ALLOWED.
6. RESIDUAL FIN UPTO 3.0 mm IS ALLOWED.
7. UNFILLING OF CORNERS ALONG $\phi 138$ UPTO R 15 IS ALLOWED.
8. UNSPECIFIED DRAFTS ARE TO BE 7°
9. UNSPECIFIED RADII ARE TO BE R 6.
10. MACHINING DIMENSIONS ARE SHOWN IN BRACKETS.
11. UNTOLERANCED DIMENSIONS ARE NOT TO BE CHECKED.

MATERIAL :- STEEL 20x2H 4A. GOST 4543-71.

WEIGHT OF FORGING :- 115.0 kg.

7

20056	TRIMMING TOOL	1500T	
20055	STAMPING DIES	DG-32	
Tool No.	DESCRIPTION	MACHINE	EQUIPT. TO BE USED.
SCALE	COMPONENT ~ T-72	MACHINE	COMPONENT / FORGING.
1:2	172-43-005 CARRIER.	DG-32	1 OFF
			H.V.F. AVADI
			DRAWING NO.
DGN. CHD. APPD. AUTHD.			FORGING DRAWING. 172-43-005/F