

1 2 3 4 5 6 7 8

D. A. NO.

A

A

B

B

C

C

D

D

E

E

F

F

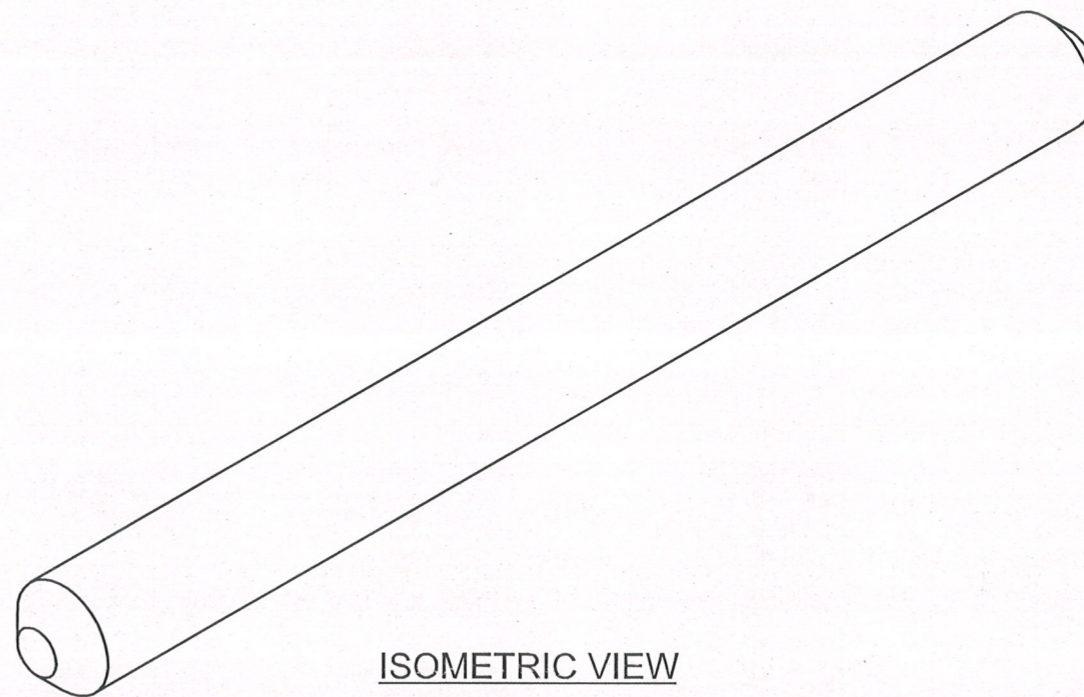
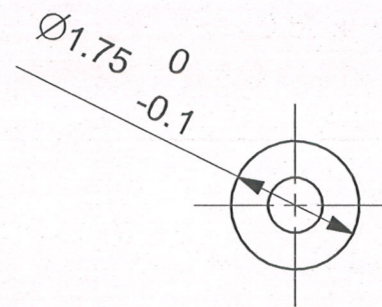
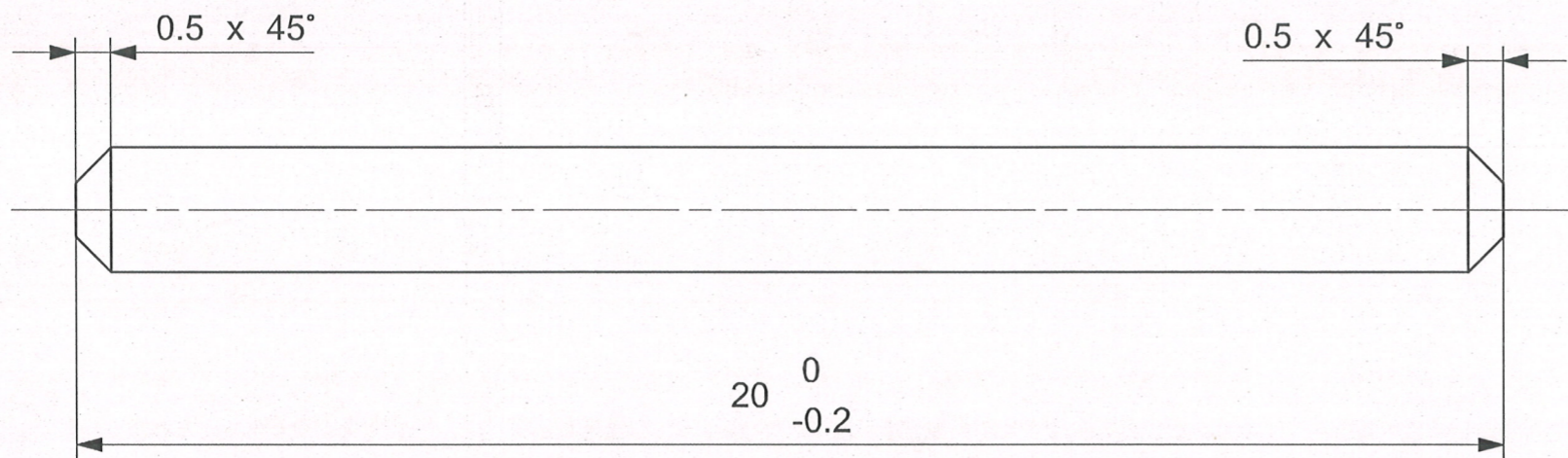

MATERIAL:- STEEL BS970 Pt.1:1983 Gd.080M40 OR En-8

HEAT TREATMENT:- HARDENED & TEMPERED TO 250 - 300 H.V.

PROTECTIVE FINISH:-PHOSPHATED TO SPECN. J.S.S.-0465-01:1988 CLASS II (ACCELERATED) OIL FINISH.

REVOLVER.32 (7.65 mm) SIDE SWING	DESIGNED BY	<i>A.S.RANA</i> A.S.RANA
	CHECKED BY	<i>JWM/DDO</i> JWM/DDO
	APPROVED BY	<i>WM/DDO</i> WM/DDO
	DATE	01.07.2019

PIN DISASSEMBLY

SCALE 10 : 1

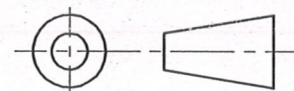

SMALL ARMS FACTORY
KANPUR

DRAWING NO.

RV-06/4 SW

SHEET 1 OF 1

DIMENSIONS ARE IN MM.

1 2 3 4 5 6 7 8 A3