

1 2 3 4
 JSS C V VV S SS CI
 C D 0 0 9 0 0 7 0 0 1 0 1 0 1 0 6 1

DRG.No.

GEN. TOL. FINE/MEDIUM/COARSE
 CLASS TO IS: 2102

DRG. CONVENTIONS CONFIRM TO INDIAN STD.
 DIMN. IN mm UNLESS OTHERWISE STATED

CRAMP TEST:-
 SPRING TO BE TESTED BEFORE GAUGING BY COMPRESSION
 TO A LENGTH OF 10.0 FOR A PERIOD OF 12 HOURS AFTER
 WHICH IT MUST CONFORM TO THE FREE LENGTH

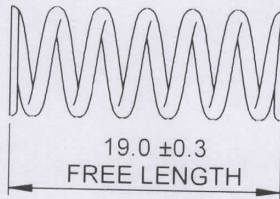
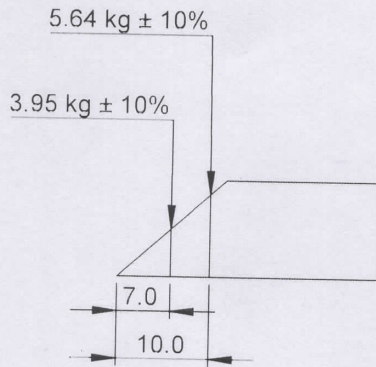

STRESS RELIEVED
 WIRE DIA:-1.0
 MEAN DIA:- 6.7±0.2
 NO. OF EFFECTIVE COILS:- 6
 WOUND:- L.H. OR R.H.
 ONE COIL OF EACH END TO BE CLOSED IN GROUND SQUARE TO THE
 AXIS OF COIL, LEAVING 3/4 COIL AT EACH END NON-EFFECTIVE

Handwritten signature

E	Sr. No.	DATE	AUTHORITY	GAURAV BRIEF RECORD	ZONE	CD	GO
	DRN. KOUSIK	CHD.	GAURAV	MATERIAL :-	STEEL TO IS:4454 (Pt-1) 2001 DH		
	DATE:01/09/2021	For Director		PROTECTIVE FINISH :-	PHOSPHATED TO SPECN.IS:3618-1966 CLASS'B'		
	APPD. DATE	SEALED DATE	EST. MASS	TITLE :-	SPRING PUSH BUTTON		
F	SCALE:- 1:	DESIGN AUTHORITY	ARDE	PUNE 411021			
	DRG.No.	1 9 0 1	0 1	0 1	0 0	0 7	0 0 6 0 0 D C
PART No.		DS CAT. No.		AHSP			

1 2 3 4

1 2 3 4
 JSS C VV S SS IC
 C D 0 0 7 0 0 1 0 1 0 1 9 0 1
 DRG.No.

GEN. TOL. FINE/MEDIUM/COARSE
 CLASS TO IS: 2102

DRG. CONVENTIONS CONFIRM TO INDIAN STD.
 DIMN. IN mm UNLESS OTHERWISE STATED

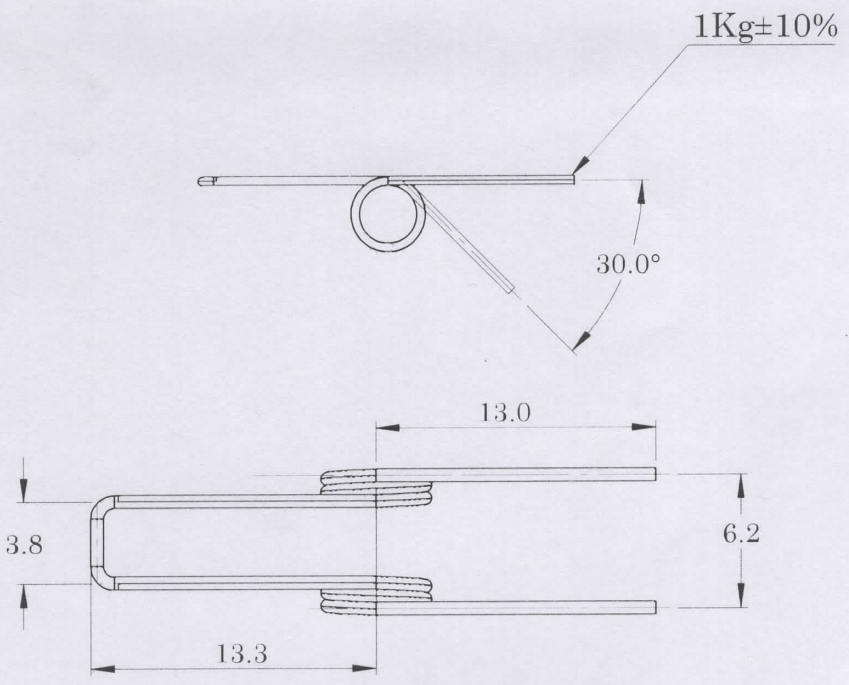

NOTES:
 STRESS RELIEVED
 WIRE DIA:0.6
 MEAN DIA:4.6±0.2
 NO OF EFFECTIVE COILS:2
 WOUND:LH OR RH

TORQUE 25.5 N-mm ± 10% FOR 30° DEFLECTION
 SPRINGS SHALL BE HARDENED AND TEMPERED TO
 REQUIRED PROPERTY.
 THE BASIC FORM OF SPRING IN FREE CONDITION
 SHOULD CONFORM TO THE DRAWING AFTER ABOVE
 TEST.

Handwritten signature and date:
 18/09/2021

Sr. No.	DATE	AUTHORITY	BRIEF RECORD	ZONE	CD	GO
					SIGN	
E	DRN. KOUSIK	CHD. GAURAV	MATERIAL :-	STEEL TO IS:4454 (Pt.1) 2001,DH		
	DATE:02/09/2021		PROTECTIVE FINISH :-	PHOSPHATED TO SPECN IS:3618-1966,CLASS'B'		
	APPD. DATE	For Director	TITLE :-	SPRING LEVER LOCKING BUTT ASSEMBLY		
	SEALED DATE					
	SCALE:- 1:	EST. MASS				
F	DESIGN AUTHORITY ARDE					
	PUNE 411021					
DRG.No.		1 9 0 1	0 1	0 1	0 0	0 7
		IC	SS	S	AA	A
PART No.		DS CAT. No.		AHSP		

Handwritten mark: (2)

1 2 3 4
 JSS C V VV S SS CI
 C D 0 0 8 0 0 7 0 0 0 1 0 1 0 1 0 6 1
 DRG.No.

GEN. TOL. FINE/MEDIUM/COARSE
 CLASS TO IS: 2102

DRG. CONVENTIONS CONFIRM TO INDIAN STD.
 DIMN. IN mm UNLESS OTHERWISE STATED

CRAMP TEST:-
 SPRING TO BE TESTED BEFORE GAUGING BY COMPRESSION
 TO A LENGTH OF 10.0 FOR A PERIOD OF 12 HOURS AFTER
 WHICH IT MUST CONFORM TO THE FREE LENGTH

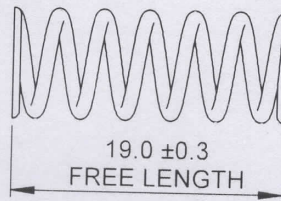
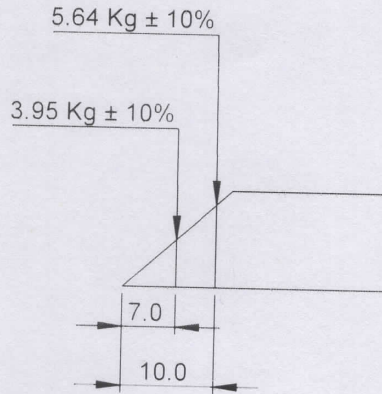

STRESS RELIEVED
 WIRE DIA:-1.0
 MEAN DIA:- 6.7±0.2
 NO. OF EFFECTIVE COILS:- 6
 WOUND:- L.H. OR R.H.
 ONE COIL OF EACH END TO BE CLOSED IN GROUND SQUARE TO THE
 AXIS OF COIL, LEAVING 3/4 COIL AT EACH END NON-EFFECTIVE

Handwritten signature and date: 01/09/2021

E	Sr. No.	DATE	AUTHORITY	GAURAV	BRIEF RECORD	ZONE	CD	GO
	DRN. KOUSIK	CHD.	GAURAV	MATERIAL :-				SIGN
	DATE: 01/09/2021	For Director		STEEL TO IS:4454 (Pt-1) 2001 DH				
	APPD. DATE	SEALED DATE		PROTECTIVE FINISH :-				
F	SCALE:- 1:	EST. MASS	TITLE :-					
	DESIGN AUTHORITY ARDE PUNE 411021			SPRING HINGE				
	DRG.No.	1 9 0 1	0 1	0 1	0 0	0 7	0 0 8	0 0 DC
	PART No.	IC	SS	S	AA	A	C	SST
DS CAT. No.			AHSP					

Handwritten mark: (5)

1 2 3 4
 ISS C A AA S SS IC
 C 0 0 0 5 0 7 0 0 0 1 0 1 9 0 1

DRG.No.

GEN. TOL. FINE/MEDIUM/COARSE
 CLASS TO IS: 2102

DRG. CONVENTIONS CONFIRM TO INDIAN STD.
 DIMN. IN mm UNLESS OTHERWISE STATED

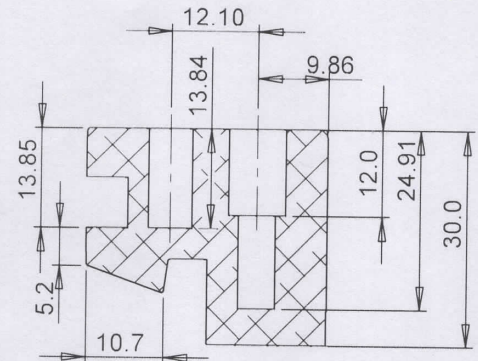
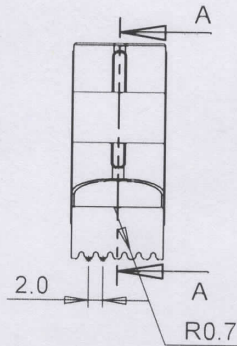
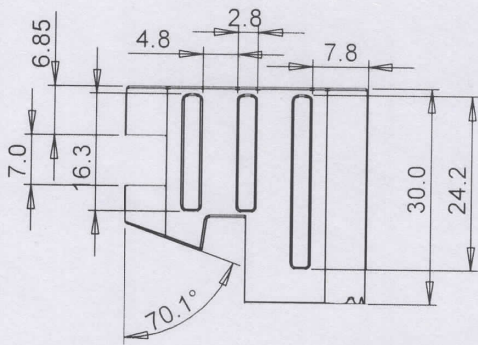
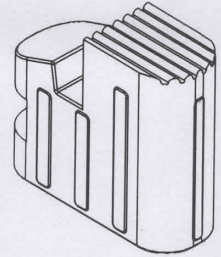
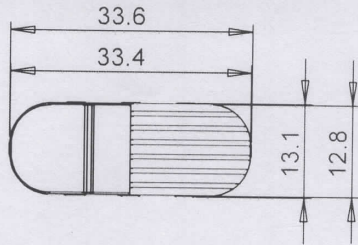

SECTION A-A
 SCALE 1 : 1

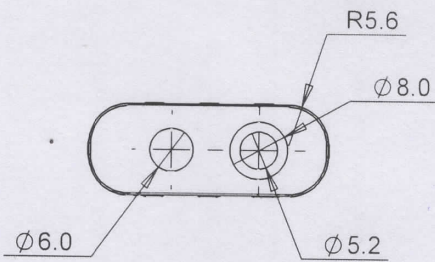

Handwritten signature

Sr. No.	DATE	AUTHORITY	BRIEF RECORD	ZONE	CD	GO
					SIGN	
DRN. KOUSIK	DATE: 10-06-2021	CHD. GAURAV	MATERIAL :-			
APPD. DATE		For Director	AL-ALLOY 64430 WP (IS:733-1983) OR EQUIVALENT			
SEALED DATE			PROTECTIVE FINISH :-			
SCALE:- 1:		EST. MASS	TITLE :-			
DESIGN AUTHORITY	ARDE		PUSH BUTTON			
PUNE 411021						
DRG.No.	1 9 0 1	0 1	0 1	0 0	0 7	0 0 5 0 0 D C
	IC	SS	S	AA	A	C SST
PART No.		DS CAT. No.			AHSP	

5

1 2 3 4
 IC 1 9 0 1 SS 0 1 S 0 1 AA 0 0 A 0 7 C 0 0 4 SST 0 0 D C
 DRG. NO.

GEN. TOL. FINE/MEDIUM/COARSE
 CLASS TO IS: 2102

DRG. CONVENTIONS CONFIRM TO INDIAN STD.
 DIMN. IN mm UNLESS OTHERWISE STATED

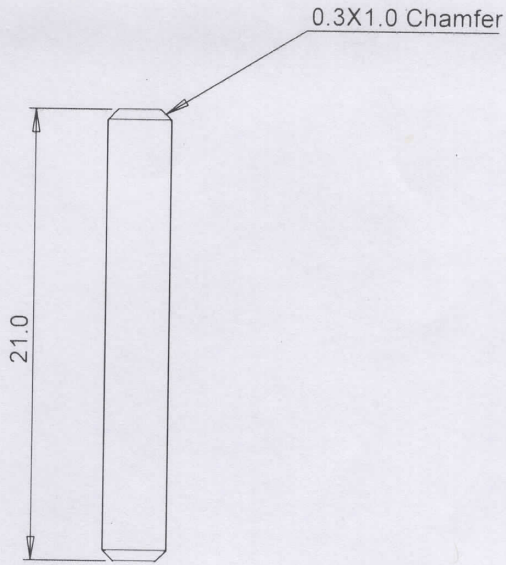

Handwritten signature and date: 19/08/2020

NOTE:
 1.REMOVE SHARP EDGES AND BURRS.
 2.HARDNESS:40-42 HRC

Sr. No.	DATE	AUTHORITY	BRIEF RECORD	ZONE	CD	GO		
					SIGN			
E	DRN. KOUSIK	CHD. GAURAV	MATERIAL :- En-31					
	DATE: 19/08/2020							
	APPD. DATE	For Director	PROTECTIVE FINISH :- PHOSPHATED TO SPECN.IS:3618-1966 CLASS'B'					
	SEALED DATE							
SCALE:- 1:	EST. MASS	TITLE :-						
F	DESIGN AUTHORITY ARDE PUNE 411021		PIN PUSH BUTTON					
	DRG.No.	1 9 0 1	0 1	0 1	0 0	0 7	0 0 4	0 0 D C
		IC	SS	S	AA	A	C	SST
PART No.			DS CAT. No.		AHSP			

1 2 3 4
 SSS C A AA S SS IC
 0000 0110 07 00 01 01 1901

DRG.No.

GEN. TOL. FINE/MEDIUM/COARSE
 CLASS TO IS: 2102

DRG. CONVENTIONS CONFIRM TO INDIAN STD.
 DIMN. IN mm UNLESS OTHERWISE STATED

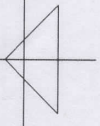
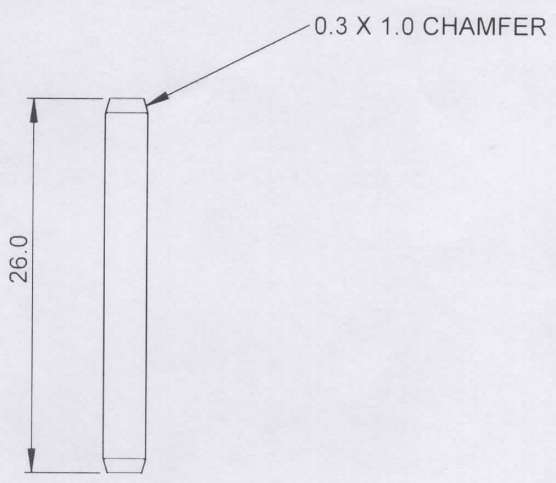

Ramkumar
 10/01/22

NOTE:
 1.REMOVE SHARP EDGES AND BURRS.
 2.HARDNESS:40-42 HRC

E	Sr. No.	DATE	AUTHORITY	BRIEF RECORD	ZONE	CD	GO	
	DRN. KOUSIK		CHD.	MATERIAL :- EN-31	SIGN			
	DATE: 19/08/2020		GAURAV					
	APPD. DATE		For Director	PROTECTIVE FINISH :- PHOSPHATED TO SPECN.IS:3618-1966 CLASS'B'				
SEALED DATE								
F	SCALE:- 1:		EST. MASS	TITLE :- PIN LEVER				
	DESIGN AUTHORITY ARDE							
	PUNE 411021							
DRG.No.		1 9 0 1	0 1	0 1	0 0	0 7	0 1 1	0 0 DC
		IC	SS	S	AA	A	C	SST
PART No.			DS CAT. No.			AHSP		

(E)

GEN. TOL. FINE/MEDIUM/COARSE
CLASS TO IS: 2102

DRG. CONVENTIONS CONFIRM TO INDIAN STD.
DIMN. IN mm UNLESS OTHERWISE STATED

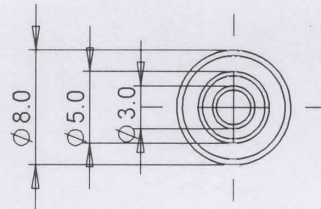
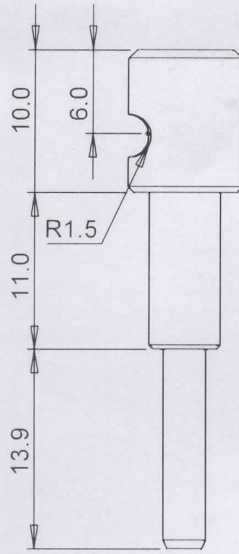

Handwritten signature and date: 19/08/2020

NOTE:
1. REMOVE SHARP EDGES AND BURRS.
2. HARDNESS: 40-42 HRC

Sr. No.	DATE	AUTHORITY	BRIEF RECORD	ZONE	CD	GO		
					SIGN			
E	DRN. KOUSIK	CHD.	MATERIAL :- En-31					
	DATE: 19/08/2020	GAURAV						
	APPD.	For Director	PROTECTIVE FINISH :- PHOSPHATED TO SPECN.IS:3618-1966 CLASS'B'					
	SEALED DATE							
F	SCALE:- 1:	EST. MASS	TITLE :-					
	DESIGN AUTHORITY		PIN LEVER LOCKING					
	ARDE PUNE 411021							
DRG.No.		1 9 0 1	0 1	0 1	0 0	0 7	0 0 3	0 0 DC
		IC	SS	S	AA	A	C	SST
PART No.			DS CAT. No.			AHSP		

Handwritten mark

1 2 3 4

1 2 3 4
 ISS C A AA S SS IC
 C D 0 0 6 0 0 7 0 0 1 0 1 1 9 0 1
 DRG.No.

GEN. TOL. FINE/MEDIUM/COARSE
 CLASS TO IS: 2102

DRG. CONVENTIONS CONFIRM TO INDIAN STD.
 DIMN. IN mm UNLESS OTHERWISE STATED

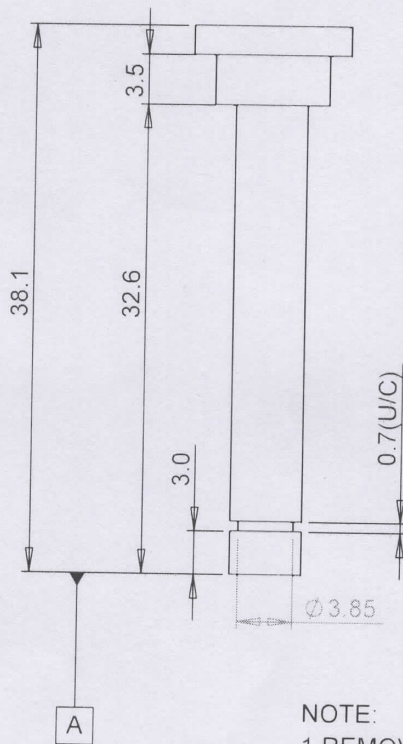
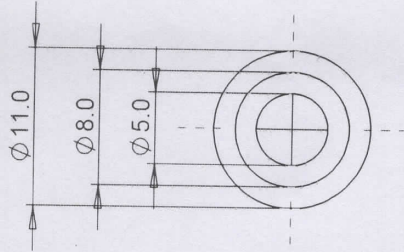

NOTE:
 1. REMOVE SHARP EDGES AND BURRS.
 2. HARDNESS: 40-42 HRC

Handwritten signature and date: 10/06/2021

E	Sr. No.	DATE	AUTHORITY	BRIEF RECORD	ZONE	CD	GO
	DRN. KOUSIK	DATE: 10-06-2021	CHD. GAURAV	MATERIAL :-		SIGN	
	APPD. DATE		For Director	En-31			
	SEALED DATE			PROTECTIVE FINISH :-		PHOSPHATED TO SPECN.IS:3618-1966 CLASS'B'	
F	SCALE: - 1:		EST. MASS	TITLE :-			
	DESIGN AUTHORITY	ARDE		PIN HINGE			
	PUNE 411021						
DRG.No.		1 9 0 1	0 1	0 1	0 0	0 7	0 0 9 0 0 D C
PART No.		IC	SS	S	AA	A	C SST
DS CAT. No.			AHSP				

Handwritten mark: (B)

1 2 3 4
 SSS C A AA S SS IC
 0 0 0 0 0 0 1 9 0 1
 0 0 2 0 7 0 0 1 0 1
 0 0 1 0 1 0 1 0 1

DRG.No.

GEN. TOL. FINE/MEDIUM/COARSE
 CLASS TO IS: 2102

DRG. CONVENTIONS CONFIRM TO INDIAN STD.
 DIMM. IN mm UNLESS OTHERWISE STATED

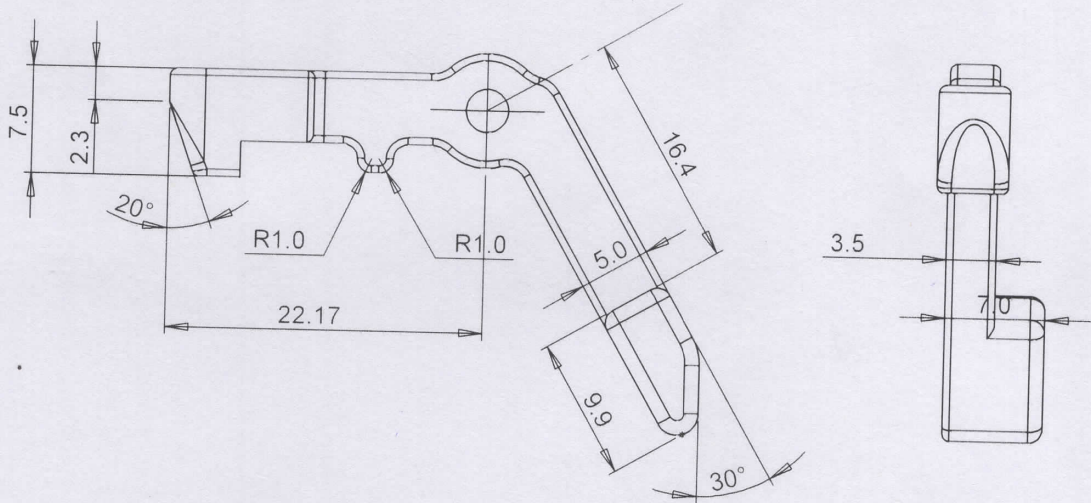
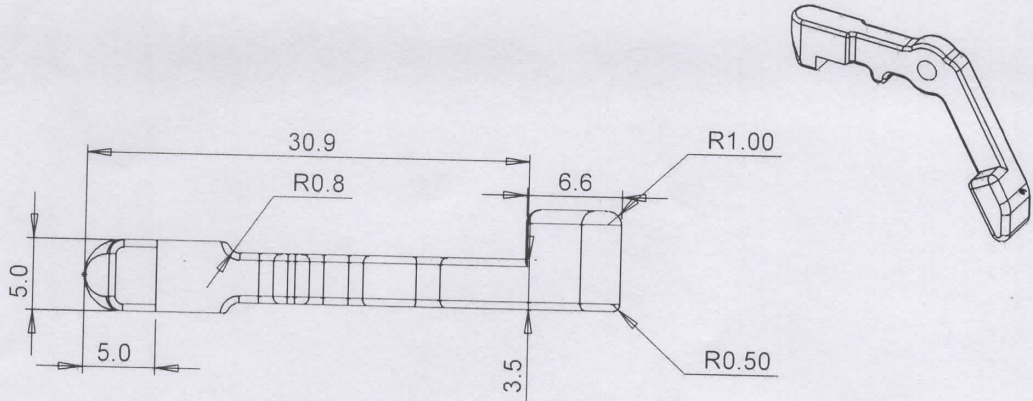

NOTE:
 1.REMOVE SHARP EDGES AND BURRS.
 2.HARDNESS:40-42 HRC

Handwritten signature and date: 19/08/2020

E	Sr. No.	DATE	AUTHORITY	BRIEF RECORD	ZONE	CD	GO
	DRN. KOUSIK	CHD.	GAURAV	MATERIAL :- En-31		SIGN	
	DATE:19/08/2020						
	APPD.	For Director		PROTECTIVE FINISH :- PHOSPHATED TO SPECN.IS:3618-1966 CLASS'B'			
DATE							
F	SEALED DATE	EST. MASS	TITLE :- LEVER LOCKING				
	SCALE:- 1:	DESIGN AUTHORITY ARDE PUNE 411021					
	DRG.No.		1 9 0 1 0 1 0 1 0 0 0 7 0 0 2 0 0 DC				
PART No.		DS CAT. No.			AHSP		

Handwritten mark: 01

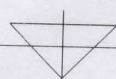

1 2 3 4
 SST C A AA S SS IC
 C D 0 0 0 1 0 7 0 0 0 1 0 1 0 1 9 0 1
 DRG.No.

GEN. TOL. FINE/MEDIUM/COARSE
 CLASS TO IS: 2102

DRG. CONVENTIONS CONFIRM TO INDIAN STD.
 DIMN. IN mm UNLESS OTHERWISE STATED

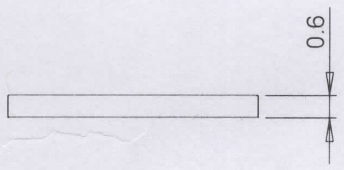
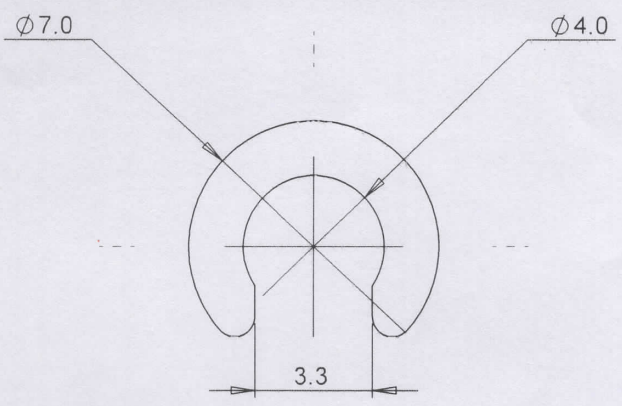

19/08/20
 Kousik
 For Director

E	Sr. No.	DATE	AUTHORITY	BRIEF RECORD	ZONE	CD	GO
	DRN. KOUSIK	DATE: 19/08/2020	CHD. GAURAV	MATERIAL :- EN-42J		SIGN	
	APPD. DATE	For Director		PROTECTIVE FINISH :-	PHOSPHATED TO SPECN.IS:3618-1966 CLASS'B'		
F	SCALE:- 1:	EST. MASS	TITLE :-	CIRCLIP PIN HINGE			
	DESIGN AUTHORITY ARDE						
	PUNE 411021	DRG.No. 1 9 0 1 0 1 0 1 0 0 7 0 1 0 0 0 D C IC SS S AA A C SST					
PART No.			DS CAT. No.		AHSP		

11

