

DIMENSIONS ARE IN mm.
 UNTOLERATED DIMNS. AS PER IS : 2102 (MED)
 MARK DRAWING No.
 SHARP CORNER TO BE BLUNT TO R0.2

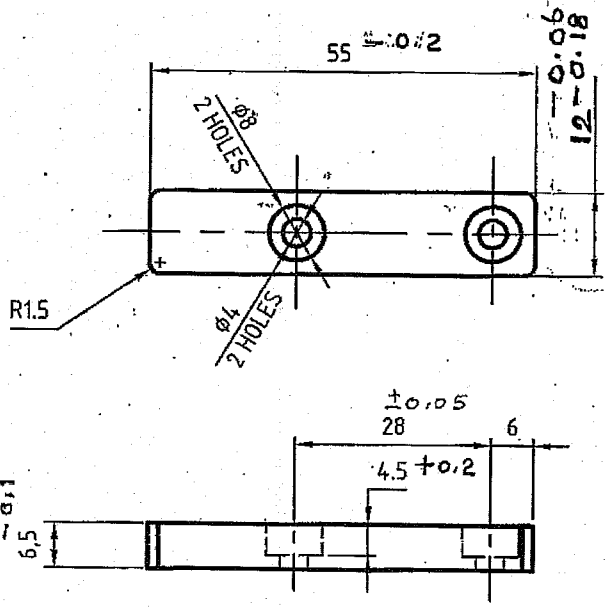

UN CONTROLLED COPY

UN CONTROLLED COPY
 CERTIFIED CORRECT COPY OF APPROVED
 DRAWINGS AT THIS DATE
 DESIGN & DRAWING OFFICE, TRU
 ORDNANCE FACTORY, TIRUCHIRAPPALLI - 620 016

DRG. PROVISIONAL

MATERIAL : ~~4130 SS~~
 Q-15: 5517-1993. DESIGN. 42Cr4 Mo2 LRS-30
 ALT. MATL : EN 19, CHROME FLASH = 0.010 mm (MAX)

PART NO.	DESCRIPTIONS	NO OFF	MATERIAL	TREATMENT	REMARKS
			AS ABOVE		RC-34-41
⊕	SIGNATURE & DATE.	SUB: SLEEVE KEY			SCALE NTS
TRACED		FOR: RECEIVER ASSY.			STORE DRG. NO.
DRAWN	<i>[Signature]</i>	OF: 14.5/20mm AMR			OPERATION NO.
CHECKED	<i>[Signature]</i>	DES. REF. NO.			
OIC/D&DO	<i>[Signature]</i>	DRG. No.: 44P 04008*2			
OFFICER/PRODN.		ORDNANCE FACTORY TIRUCHIRAPPALLI-16.			SHEETS: 1
OFFICER/D&DO					SHEET No.: 1
AMENDMENTS	SIG. & DATE	APPROVED ON.	08/2005		

DA No. 047/19
 Dt. 18/7/19
 DA No. 07/19
 Sl. No. 4
 18/7/19
 28-05-19
 SIG. & DATE