

1. PRESSURE DIE CASTING GROUP I OST 3-4227-79.
2. PATTERN DRAFT 30° IS MADE AS PER DIMENSIONS U ABOVE TOLERANCE TO THE DECREASE OF DIMENSIONS, AS PER DIMENSIONS K TO THE INCREASE OF DIMENSIONS AS PER OTHER DIMENSIONS WITHIN LIMITS OF TOLERANCES.
3. UNSPECIFIED MOULDING RADII ARE 2 mm MAXIMUM.
4. UNSPECIFIED LIMIT DEVIATIONS OF RADII ARE AS FOLLOWS:
 FROM 0.5 TO 1.0 - ±0.3 mm
 FROM 1.0 TO 3.0 - ±0.5 mm
5. NON-FLATNESS OF THE SUPPORT SURFACE OF THE FLANGE ON BOTH SIDES IS 0.5 mm MAXIMUM.
6. MARK TYPE NO-10 PMAU, 2497-75.
7. MARK CORE PRINT M TO PMAU, 2497-75.
8. MARK NUMBER OF THE MOULD DOUBLE TYPE NO-6 PMAU, 2497-75.

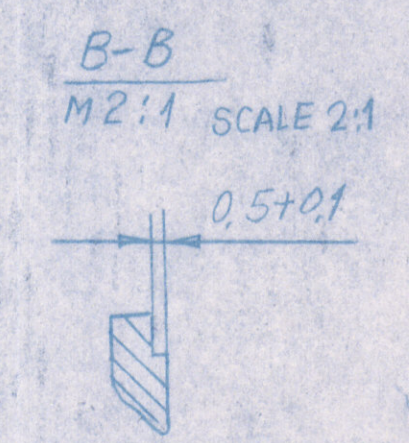

* MTL:- IS: 617-1994
 Gr. 4600'A'
 MATL. OK. UPDATED ON 02-9-03

ITEM DESCRIPTION		NO. OF MATERIAL	
LIST OF PARTS			
FOR GENERAL MANAGER OPTO ELECTRONICS FACTORY DEHRADUN			
S. NO.	AMENDMENTS	DR.	SIG.
BODY MOULDING		DRN	TCD
		CKD	JWM/QJA
MTL: IS 617-1994 Gr. 4600'A' WAS IS: 617-1994		DATE: 2-2-03	
SCALE: 1:1		DRG. NO: B-26/DC/802025/173-M	
		SHEET NO	