

DRAWING NO.
ARM 1172 B5

FOR EXPLANATION OF DIMENSIONING ETC, SEE IS: 696

TO BE STAMPED ON FLANGE IN 6
TYPE BEFORE METAL SPRAYING.

*MANUFACTURERS INITIALS
-DATE OF MANUFACTURE
(MONTH YEAR ie. 1/60)

MATL: ARM-94

CONCENTRICITY

THE 9.25 - 8UNS - 1A B.S. 1580 THD &
THE 2.75 - 12UNS - 1B B.S. 1580 THD. ARE

TO BE CONCENTRIC WITH
THE H 237.74 DIA. WITHIN 25
SYMMETRY

THE TWO 20.32 WIDE SLOTS ARE
TO BE SYMMETRICAL WITH THE
292.1 DIA WITHIN 38

SQUARENESS: THE 9.25 - 8UNS - 1A B.S. 1580 THD. MUST BE SQUARE
WITH FACE X WITHIN .050 MEASURED AT EXTREME DIA

FINISH

THE SURFACE 'Y' TO BE COATED WITH VARNISH (2 COATS) IND/ME/674 (b) METRIC & STOVED

(e) THE SURFACES INDICATED THUS --- ARE TO BE SHOT BLASTED FOLLOWED IMMEDIATELY BY A SPRAYED METAL COATING

(b) ALL SCREW THREADS ARE TO BE PROTECTED DURING SHOT BLASTING AND METAL SPRAYING

(c) APPLY ONE COAT OF PAINT, FINISHING AMMN
(AIR DRYING) TO SPEC. IS: 168 TO THESE SURFACES.

(d) SHOT BLASTING & METAL SPRAYING TO BE IN ACCORDANCE WITH SPEC DT D&P(AIR)/32/ARM
FOR NOTES (e) AND (f) SEE ABOVE

FINISHING COAT TO BE DEEP BRONZE GREEN TINT NO 224, TINT TO CONFORM TO IS: 5 OF 1961

THREADS TO BE FREE FROM PAINT & VARNISH & COATED WITH LUTING (THIN) MK B
(APC-10) TO SPEC. JSS 1-65-09

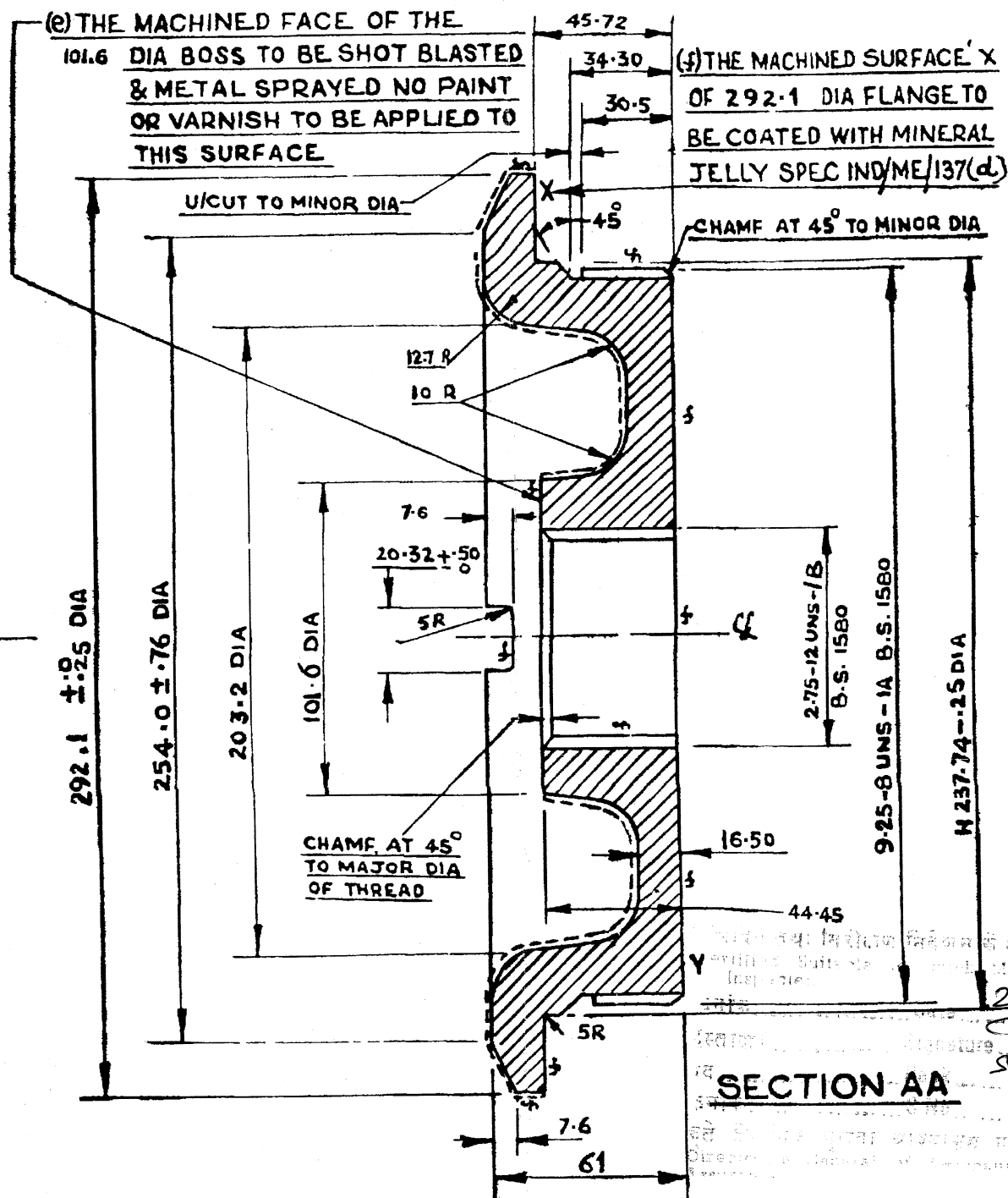
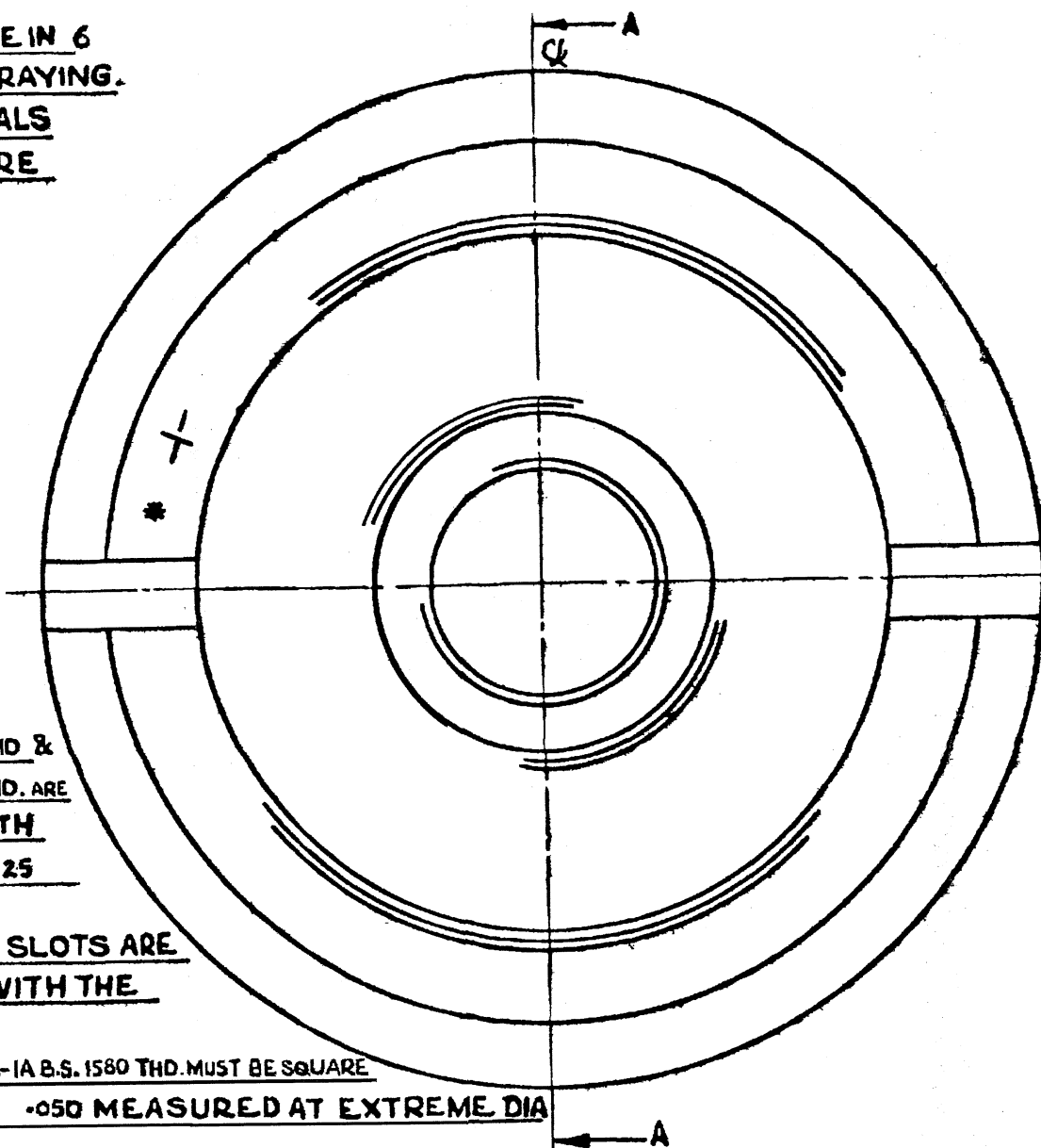

SECTION AA

R NO DATE ZONE BRIEF RECORD INITIAL

4	25-4-89	-	AMENDED VIDE AL No 630	da
3	24-11-79	-	AMENDED VIDE AL 367	
2	19-1-73	-	RETRACED & AMENDED VIDE AL No 186	RAU
1	11-9-63	-	ORIGINAL	

	DATE	INITIAL	DIMNS. IN MM OR AS STATED
DGN			MATL. SPEC.
DRN			AS STATED
CHD			I.A.F. SEC REF. NO.
TCD		MSJ	ASSY DRG No ARM 1172 E2 / ARM 1302 D2
COMP			DRG SCHD NO ARM 1172 / ARM 1302
SCALE - 1:2			
TOL -			
TOL EXCEPT WHERE OTHERWISE STATED (MACH DIMN ±.25 UNMACH DIMN ±.75)			

D.T.D.&P.(AIR)
MINISTRY OF DEFENCE

APPROVED *R. B. Chang*
DRAWING NO.
ARM 1172 B5