

DS CAT No
5360-007188

DIMENSIONS ARE IN mm UNLESS OTHERWISE STATED

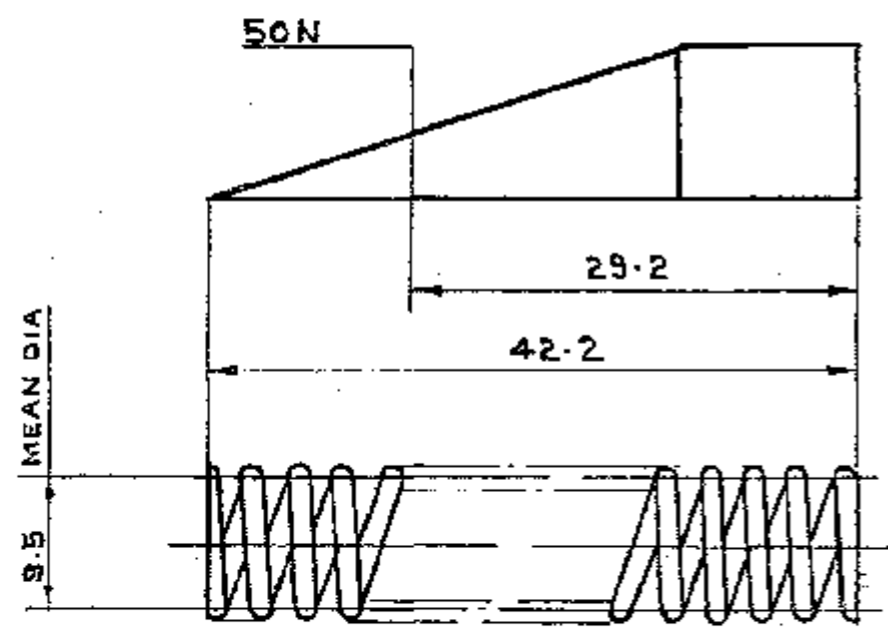

"COMPRESSION TEST AS PER BS : 1726, Pt-1 100 % FOR FIRST 20 SPRINGS & 10 % FOR REMAINING PRODUCTION OR AS ORDERED BY CIW"

"SPRING TO CONFORM TO BS : 1726, Pt-1 - CATEGORY II, CLASS-B"

DIA OF WIRE-----1.5
 No OF EFFECTIVE COILS-----15
 WOUND-----RH OR LH

ONE COIL AT EACH END TO BE CLOSED IN & GROUND SQUARE WITH THE AXIS LEAVING 3/4 COIL NON-EFFECTIVE AT EACH END

				DRAWN:-		CHD:-		ASSY DRG:-1015-000194		CQA(W), JABALPUR	
				SCANNED.- RC		CHD:- <i>Ahsp</i>		DATE:-			
15-11-07				SCANNED & PRINTED WITHOUT CHANGE				<i>Cal</i>			
DATE	AUTHORITY	ZONE	AMENDMENTS	SIG AHSP	SIG DO	MATERIAL:- IS : 4454-Pt-1, GRADE-3		SCALE:- 2 : 1			
PREV DC Nos:- 15264-W, 17264 W & 18639-W dated 05-07-01						PROTECTIVE FINISH:- PHOSPHATING TO SPECN. JSS : 0465-01: 1988, CLASS-II, FINISH (J)		ESTD mass:- 1.47 g		DESIGN No. ARDE 1279 / 49	
DRG SEALED - 15264-W dated 04-09-78						SPRING HELICAL COMPRESSION				PART No. IFL 7655	
										DS CAT No. 5360-007188	

DO CQA(W)