

FOR EXPLANATION OF DIMENSIONING ETC, SEE CQA(I) GUIDE No 001-1992
THIRD ANGLE PROJECTION.

A

| LETTER | NAME | QUANTITY |
|--------|-------|----------|
| A | PLATE | 1 |
| B | CLIP | 2 |

D.C.W.:-2565-S,1355-I,2684-I,5400-I,5810-I

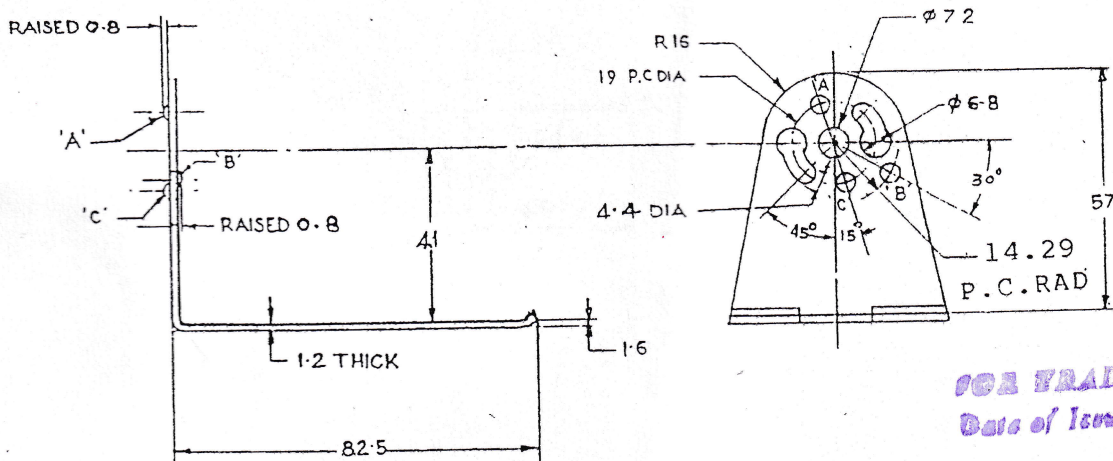
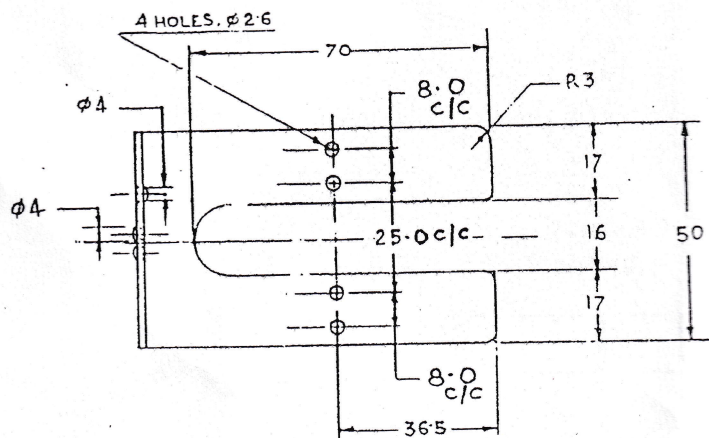

FOR TRADE COPY
Date of Issue 17/9/2010
New

NO. 18 SWG = 1.2

FINISH- PRIMER TO IS:104-1979 (3rd PRINT MAR'91)
AND THEN APPLY WITH PAINT(ISC-220
OR 225 TO IS:5-1978) TO IS:168-1973
EXTERNALLY

NOT TO SCALE

CAT/PART No
5340-007322

PLATE

DRG REDUCED & METRICISED AT COA(I) DEHRADUN
PREPARED BY [Signature] CHECKED : [Signature]
FOR QM. W
DATE: 6.12.93

| | | | |
|--|--|--|-----------------------------------|
| | | CIA(F.C)1362 DETAIL No. 16 | Sd/- 31-10-01 |
| | | DRAWN [Signature] Traced [Signature] | CHECKED [Signature] FOR C.I.A. |
| | | SCALE: - NOT TO SCALE | |
| | | MATERIAL: BRASS CuZn30, HB OF IS:1410-1977 (THIRD REVISION) | |
| | | SEALED: - 14-10-01 | |
| | | SUPPLIER'S No. | |
| | | O.S. 14630 | |
| | | 2 SHEETS | |
| | | SHEET 1 | |

BRACKET

23

FOR EXPLANATION OF DIMENSIONING ETC, SEE CQA(I) GUIDE No. 001-1992
 THIRD ANGLE PROJECTION - DIMENSIONS ARE IN mm.

B

DC(I) :- 2565-S, 2684-J, 5400-I.5810-I

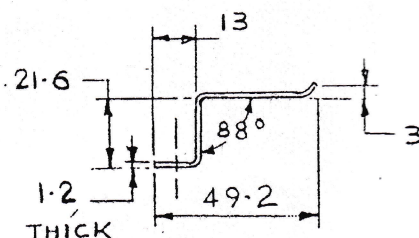
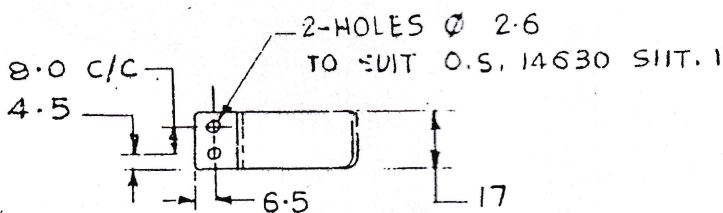

FOR TRADE ONLY

Date of Issue 17/9/2020

Handwritten signature

MATL:-

BRASS, Cu Zn 30, HB OF IS:410-1977 (THIRD REVISION)
 FINISH- PRIMER TO IS:104-1979(3rd PRINT MAR' 91)
 AND THEN APPLY WITH PAINT (IS: 220
 OR 225 TO IS:5-1978) TO IS:168-1973
 EXTERNALLY.

CLIP 2-OFF

GAT/PT No
 5340-007322

DRG. REDUCED & METRICISED AT CQA(I) DEHRADUN
 PREPARED BY: [Signature] CHECKED FOR QM [Signature]
 DATED:- 8.12.93

| | | | |
|--|----------|--------------------------------------|------------|
| | | CIA(F.C)1362 | sd- |
| | | DETAIL No-17 | 31.10.1941 |
| | | DRN- [Signature] TCD [Signature] CHD | FOR C.I.A |
| | | SCALE:- NOT TO SCALE | |
| D.C.5810-I, METRICISED, UPDATED & REDUCED DRG SEALED IN SUPERSESSION OF EXISTING ONE | 21.12.93 | MATL:- SEE ABOVE | |
| AMENDMENTS | DATE | SEALED - 14-10-41 | |
| BRACKET | | SUPPLIER'S No. | |
| | | O.S.14630 | |
| | | 2-SHT'S | SHT-2 |

24