

2

DWG NO Y28656A-00

SH 1

1

THIS DOCUMENT AND THE INFORMATION CONTAINED IN IT ARE PROPRIETARY AND CONFIDENTIAL TO OFT. NO PERSON OR ENTITY IS ALLOWED TO COPY, REPRINT, REPRODUCE OR PUBLISH ANY PART OF THIS DOCUMENT, NOR DISCLOSE ITS CONTENTS TO OTHERS, NOR MAKE ANY USE OF IT, NOR ALLOW OR ASSIST OTHERS TO MAKE ANY USE OF IT UNLESS BY THE PRIOR WRITTEN EXPRESS AUTHORIZATION OF OFT AND THEN ONLY TO THE EXTENT AUTHORIZED. COPYRIGHT-OFT.

SHEET REV RECORD

ALL SHEETS ARE THE SAME REVISION

REVISION RECORD

REV	ECO	DESCRIPTION	DATE	APVD
--		Released	12-Feb-19	L. Goldshtein

NOTES:

- INTERPRET THIS DRAWING IAW ASME Y14.100M.
- UNLESS OTHERWISE SPECIFIED DIMENSIONS ARE IN MM PER ASME Y14.5
- MATERIAL: ALLOY STEEL PLATE SAE 4130 NORMALIZED PER SAE-AMS-6345 OR SAE 4340 NORMALIZED PER AMS-6359 (PROVIDE USE PLATE 5 MM THICK. (✓)).
- UNLESS OTHERWISE SPECIFIED, UNDEFINED MACHINED FILLET RADII SHALL BE 0.2...0.3.
- DEBURR AND REMOVE SHARP EDGES, APPROX. 0.2X45 Deg.
- ALL DIMENSIONS ARE AFTER HEAT TREATMENT AND BEFORE COATING.
- PARENTHETICAL FIGURES ARE FOR REFERENCE ONLY.
- DEBUR AND REMOVE SHARP EDGES WITH RADII 0.5 APPROX. BY HAND WORK UP.
- HEAT TREATMENT TO 35±3 HRC PER AMS 2759/1.
- COATING: A DRY FILM LUBRICATION IN A FLUOROPOLYMER ORGANIC RESIN CLASS 2 COLOR MATTE BLACK TYPE I; 15-25 MICRON THICK PER VS-1-3-1-165 (OR EQUIVALENT).
- QUALITY ASSURANCE PROVISIONS ANSI/ASQC Z1.4 ALL DIMENSIONS AND FINISH PER SQUEGLIA C=0 AQL 2.5% KEY DIMENSIONS 100% INSPECTION (MARKED BY FLAG KEY) VISUAL INSPECTION 100%.
- PACKAGING AND PACKING: THE FINISHED PART SHALL BE PRESERVED AND PACKAGED IN ACCORDANCE WITH MANUFACTURER'S BEST COMMERCIAL PRACTICE.
- IDENTIFY PER MIL-STD-130 PARA 4.1.B, BY LABELING ITS CONTAINER WITH THE PART NUMBER. CHARACTERS MINIMUM TEXT HEIGHT 1.25 MM.

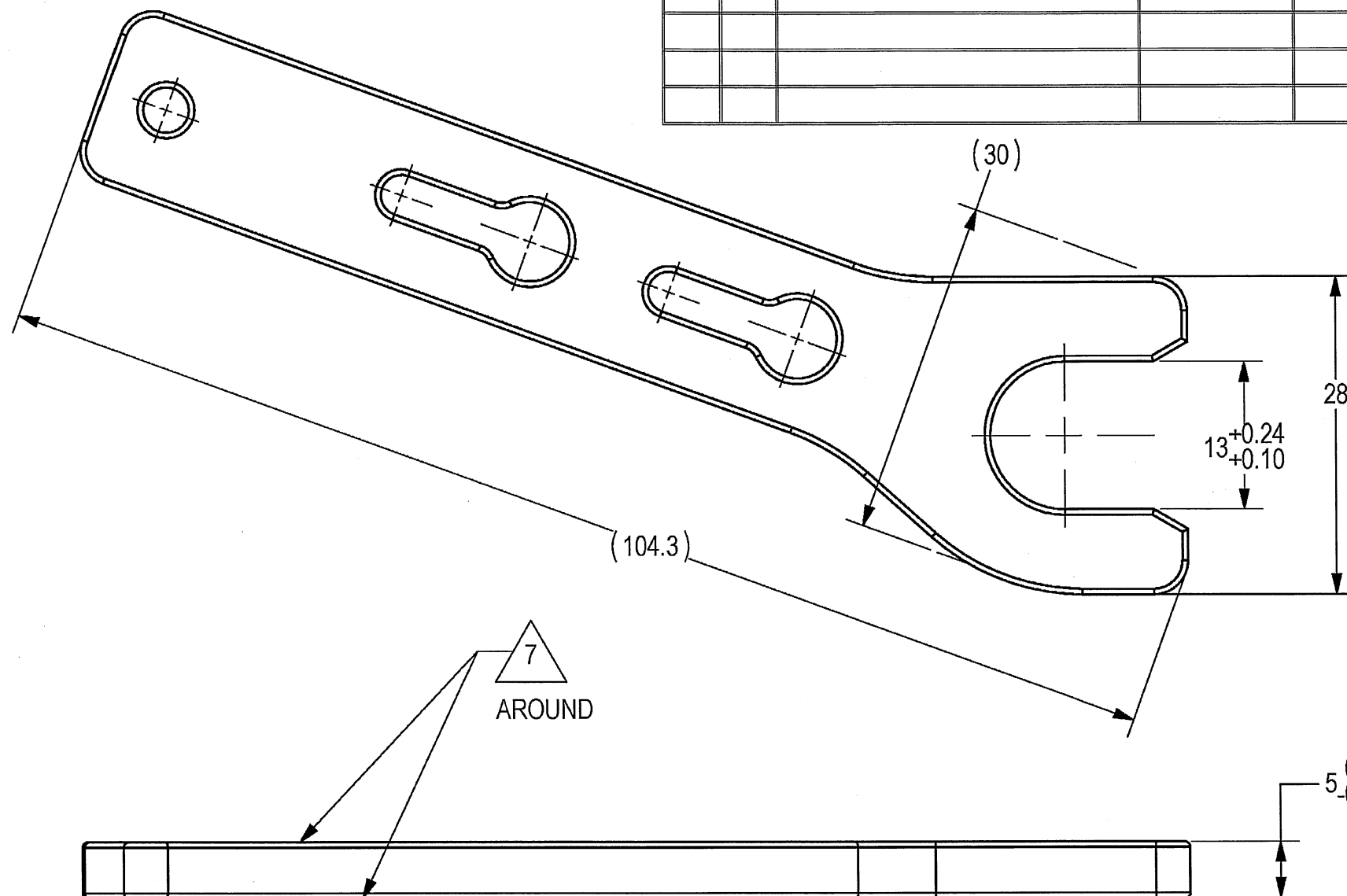

SEE ATTACHED MEDIA

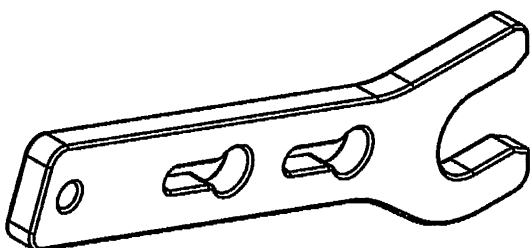

3.2/

UNLESS OTHERWISE SPECIFIED		SIGNATURE	DATE	ORDNANCE FACTORY TIRUCHIRAPPALLI	
PROFILE:	N/A	DRAWN	<i>Kay</i> 11/9/20	FOR: STAND WEAPON ASSY	
TOLERANCES		CHECKED		TITLE	
LINEAR	ANGULAR	HOS/DDO	<i>P. J. M.</i> 3/5/20	WRENCH	
ISO-2768-m	ISO-2768-m	OFFICER/PRODN		FOR: 12.7MM SRCG	
1st ANGLE PROJECTION		OFFICER/QC		SIZE	CAGE CODE
		OFFICER/DDO	<i>Q</i> 3/9	B	2291A
PROJECT OFFICER	<i>Imresh</i>			DWG NO	Y28656A-00
Approximate Weight:	0.03 [kg]	SURFACE TEXTURE IN Micro Meter		SCALE	2:1
		PLM Control		AUTOMATED DRAWING (SW)	SHEET 1 OF 1

2

1