

8	7	6	5	4	3	2	1	
DS CAT No.		DRG CONVENTIONS CONFORM TO IS : 696						
5360-040401		DIMENSIONS ARE IN mm UNLESS OTHERWISE STATED						
		TOLERANCES FOR UNTOLERANCED LINEAR DIMENSIONS						
ABOVE	-	6	30	120	315	1000	2000	4000
UP TO	6	30	120	315	1000	2000	4000	-
TOLS	± 0.1	± 0.2	± 0.3	± 0.5	± 0.8	± 1.2	± 2	± 3

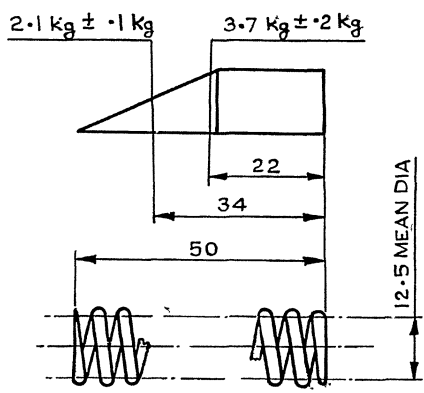

NOTE :- COMPRESSION TEST AS PER BS : 1726 Pt 1 100% FOR FIRST 20 SPRINGS & 10% FOR REMAINING PRODUCTION OR AS ORDERED BY AHSP. SPRINGS TO CONFORM TO BS : 1726 Pt 1 CATEGORY III CLASS 'B'

DIA OF WIRE1.25 mm
 No OF EFFECTIVE COILS9.5
 WOUND RH OR LH

ONE COIL AT EACH END TO BE CLOSED IN GROUND SQUARE WITH THE AXIS LEAVING 3/4 COIL NON EFFECTIVE AT EACH END.

DRAWN -		CHD:-		ASSY DRG:- 1015 - 003179		CQA(W), JABALPUR	
24-5-08		19127-W		MATEL., DS CAT No. & NOMEN. AMENDED,			
17-3-07				SCANNED & PRINTED WITHOUT CHANGE		AHSP	
DATE		AUTHORITY		ZONE		AMENDMENTS	
PREV DC Nos:- 17827-W, 18825-W & 18844-W Dt. 03-01-04		SIG AHSP		SIG DO		MATERIAL:- IS : 4454 Pt I, 2001, Gde "SH" OR "DH"	
DRG SEALED:- 18844-W Dt. 03-01-04		DO CQA(W)		PROTECTIVE FINISH:- TO BE PHOSPHATED TO SPEC JSS : 0465-01 : 1988, CLASS II. FINISH - (J)		SCALE:- 1 : 1	
						ESTD mass:-	
						DESIGN No. ILG 127	
						PART No. IFL 8075	
						DS CAT No. 5360-040401	