

THIS DRAWING IS THE PROPERTY OF O.F. BHUSAWAL
 MINISTRY OF DEFENCE, GOVT. OF INDIA. IT SHOULD NOT
 BE COPIED / REPRODUCED IN ANY WAY

27 OCT 2014

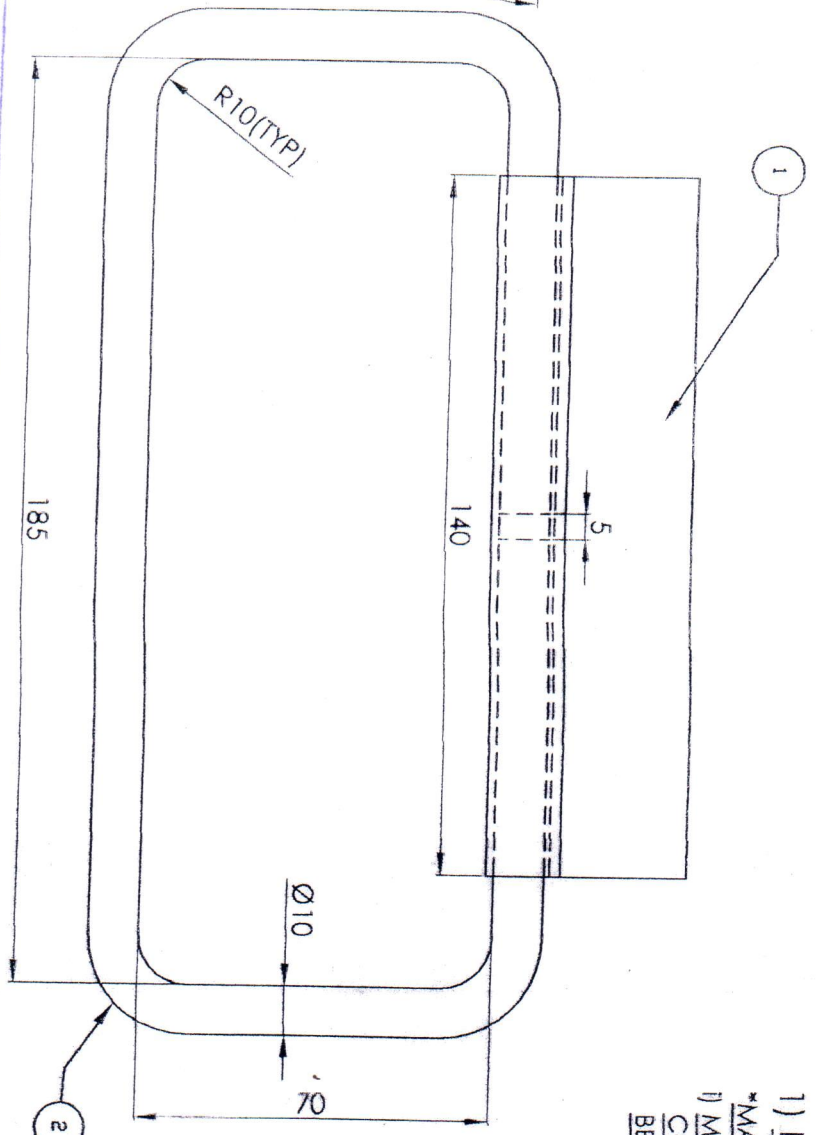
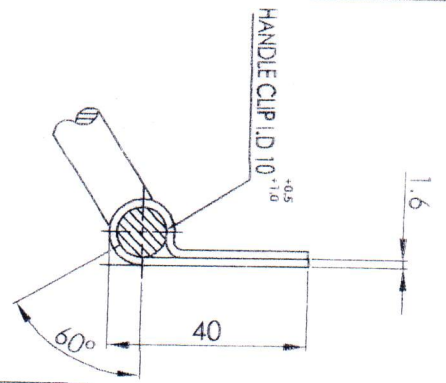

ICL CONFORMING TO IS 2102(MED)

1) HANDLE CLIP (REF DRG. ISV 2040)

* MATERIAL:
 i) MILD STEEL SHEET TO SPEC IS 513-1996
 COLD ROLLED & ANNEALED TYPE 'D'
 BEST SURFACE.

2) HANDLE (REF DRG. ISV 2039)

* MATERIAL:
 i) BAR STEEL TO SPECIFICATION
 IS:2062-1992 GRADE Fe 410 WB.

NOTE:
 i) THIS HANDLE WITH HANDLE CLIP ASSEMBLY ARE USED IN BOX C 53 A.
 ii) HANDLE TO BE RUST PROOF BY ANY APPROVED METHOD
 iii) HANDLE MUST ROTATE FREELY INSIDE THE CLIP AFTER ASSEMBLY.
 iv) THESE DRGS ARE MADE AS PER STANDARDISATION PROPOSAL OF O.F. BHUSAWAL.

सहायक संचालक (प्रमुख),
 कारखाना भुसावल,
 लालबाग, भुसावल,
 ऑफिस, गुजरात.
 २७/१०/२०१४
 Head of Ordnance, Bhushawal Factory,
 Lalbag, Bhushawal,
 Office, Gujarat.

R.NO.	DATE	AUTHORITY	REVISION	SIGN.
1307-2004	DC 36970 - A	DRG SEALED & COMPONENTS STANDARDISED		

DRG. SEALED :- 13-07-2004

ITEM	DESCRIPTION	QTY.	MATL.	TREATMENT	REMARKS
TITLE :- HANDLE WITH HANDLE CLIP ASSY HA2 (FOR C53A) (REF PART NO. ISV-2095)					
NOTE :- 1) ALL DIMENSIONS ARE IN MM. 2) UNSPECIFIED TOLERANCES AS PER IS 2102 (MED).					
SCALE: 1:1.5					
ORDNANCE FACTORY BHUSAWAL					
DGN./DRN.	PAVANKUMAR				05/10
CHD.	P.V.RAO				05/10
HOS/DO	D.L.PATIL				05/10
DIV.O/DO	P.K.BHUMBERKAR				05/10
HOS/SHOP					05/10

ID NO: C/DRG 3/STD COMP/HANDLE CLIP ASSY
 DRG NO: OFB/C/1466A