

DRAWING NUMBER
315-617-2

✓(✓)

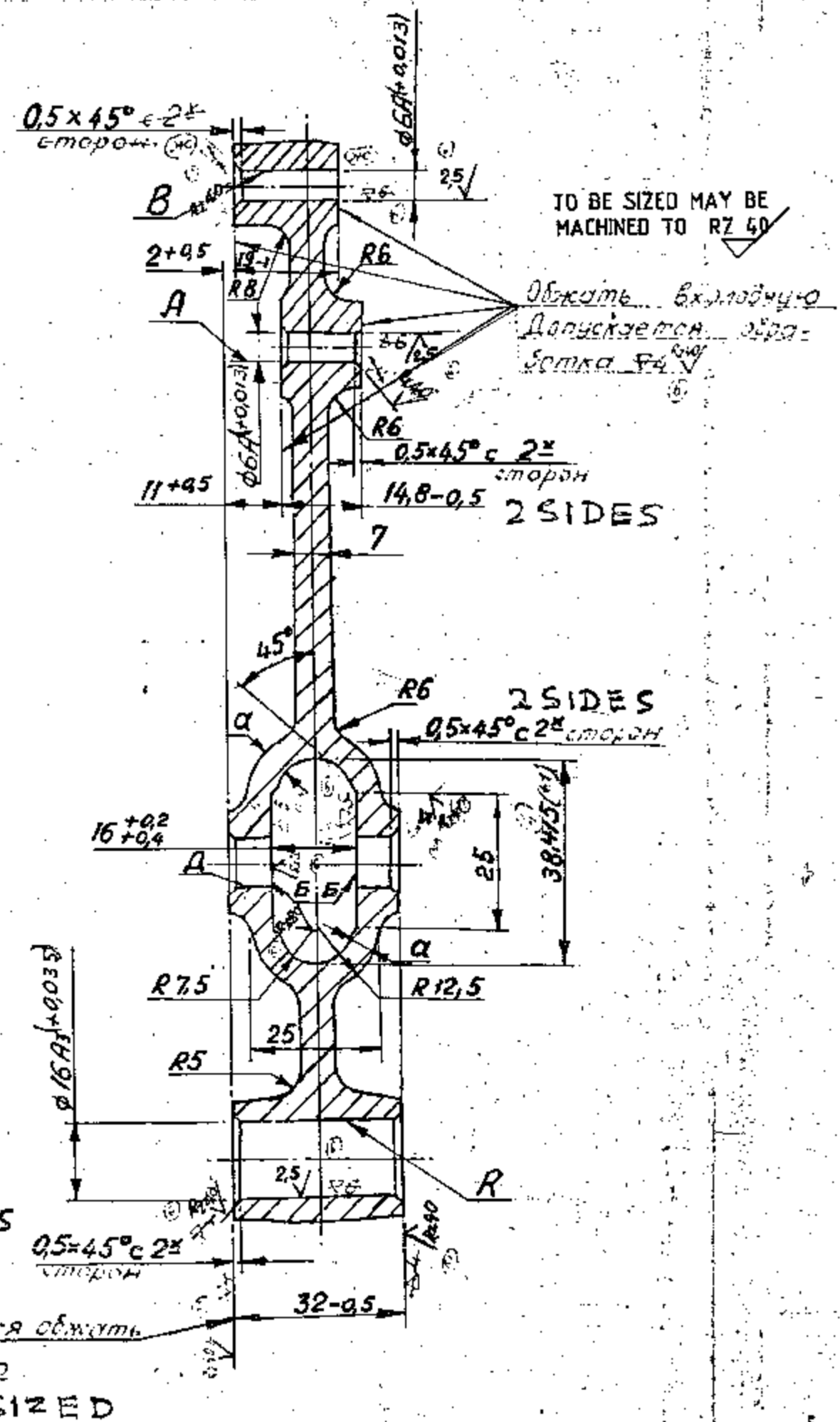
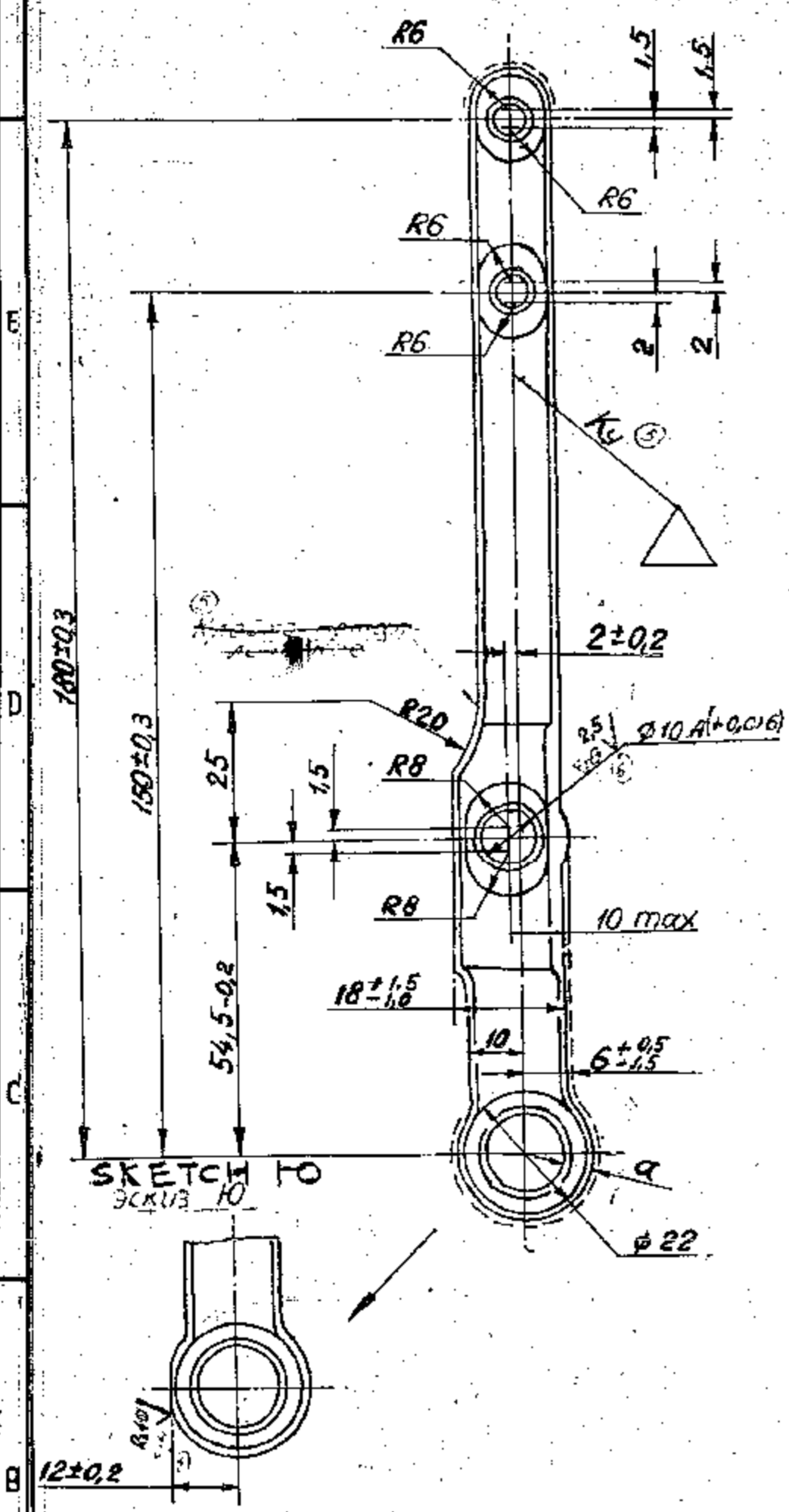

1. REQUIREMENTS FOR STAMPING AS PER GOST 7505 - 74 APPENDIX 1.
2. UNSPECIFIED RADII OF STAMPING SHOULD BE 2 TO 3mm.
3. DIMENSIONS WITH UNSPECIFIED TOLERANCES SHOULD BE OBTAINED AS PER A7, B7, OST 1010.
4. SHIFT OF AXES OF HOLE A AND B RELATIVE TO THE BOSS AXIS OF SYMMETRY MAY BE 2mm ALONG THE LEVER, AXIS AND 1mm IN THE DIRECTION PERPENDICULAR TO THE LONGITUDINAL AXIS.
5. NON PARALLELISM AND CROSSING OF AXES OF SURFACES 'K' AND B SHOULD NOT EXCEED 0.15mm ON A LENGTH OF 50mm.
6. NON SQUARENESS OF SURFACES G TO THE AXIS OF HOLE A IS TO BE CHECKED BY ROTATING THE ROLLER WITH DIMENSIONS DIA. 23.8 x 16 CONSTRUCTED IN COMPLIANCE TOLERANCES FOR GANGES ON PIN DIA. 10mm (IT IS ALLOWED TO CHECK WITH ROLLER WITH DIMENSION DIA. 23.8 x 15.9)
7. NON PARALLELISM OF AXIS OF SURFACE K TO THE AXIS OF HOLES SHOULD NOT EXCEED 0.15mm ON A LENGTH OF 50mm.
8. CROSSING OF AXIS OF SURFACE K WITH AXIS OF HOLES SHOULD NOT EXCEED 0.15mm ON A LENGTH OF 50mm.
9. VARIATION IN WALL THICKNESS OF DIMENSION 'a' SHOULD NOT EXCEED 1.5mm.
10. ALTERNATE MATERIAL: STEEL GRADE 30, 35, 40 AND 45 GOST 1050-74.
11. MARKS IN COMPLIANCE WITH STANDARD ARE ALLOWED ON SURFACES A, B, AND K.
12. ON THE SURFACES MARKED WITH DOTTED LINE FINS FROM STAMPING SHOULD BE DRESSED.
13. SHARP EDGES SHOULD BE BLUNTED.
14. MAY BE MANUFACTURED AS PER SKETCH 10.
15. LOCAL DEPRESSIONS UP TO 0.5mm DEEP ARE ALLOWED ON THE UNMACHINED SURFACE.
16. COATING: CHEMICAL OXIDIZING OIL FINISHING.

PILOT SAMPLE SHOULD BE APPROVED BY A H S P BEFORE BULK PRODUCTION.

EST. MASS 0.24 Kg TO BE STAMPED OR MARKED WHERE INDICATED THUS # LETTERS)

ALL SHARP EDGES AND CORNERS TO BE REMOVED UNLESS OTHERWISE STATED MACHINED CORNERS TO HAVE R OUTSIDE R INSIDE EQUIVALENT CHAMFERS ARE PERMISSIBLE.

DRN		MATERIAL:- STEEL 20	USED ON:-
CHD		GOST 1050-74 STAMPING	CB 315-665
TCD		CONTROLLERATE OF INSPECTION (HEAVY VEHICLES) AVADI	
APPO		TITLE:-	
DATE	09-5-86	REGULATOR LEVER	
SCALE - 1:1		D S CAT NUMBER	
DIMENSIONS IN mm.		DRAWING NUMBER	
TOLERANCE ON DIMNS UNLESS OTHERWISE STATED.		315-617-2	
ALL THREADS CONFORM TO			
ISSUE	DATE	NATURE OF AMENDMENTS	

A 6
SIZE A2



DRAWING NUMBER

315-636-1

R=20 (✓)

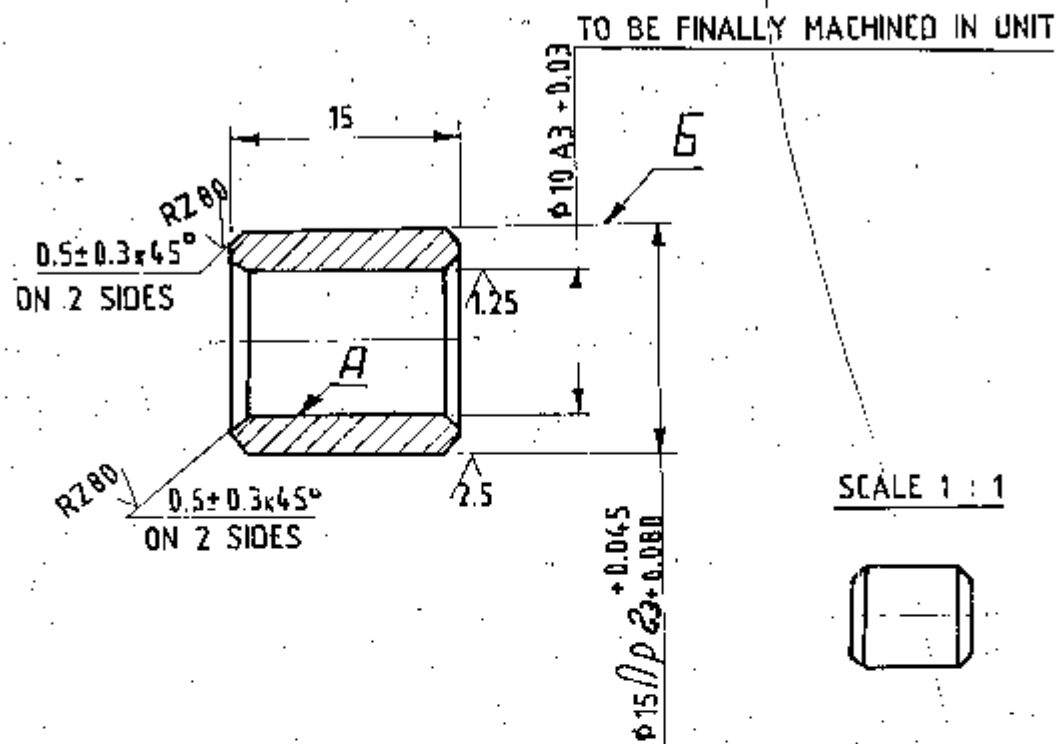

1. DIMENSIONS WITH UNSPECIFIED DEVIATIONS SHOULD BE OBTAINED AS PER ACCURACY CLASS 7 OST 1010.
2. RUN-OUT OF SURFACE B RELATIVE TO SURFACE A SHOULD NOT EXCEED 0.05mm.

EXPLANATORY NOTE:

MATERIAL QUOTED: AC 59-1 GOST 15527-70
AC 59-1 GRADE OF BRASS

CHEMICAL COMPOSITION (AS PER GOST 15527-70) %

COPPER : 57.0 - 60.0
LEAD : 0.8 - 1.5
ZINC : REMAINDER

ADMIXTURES

IRON : 0.5 (MAX) ANTIMONY : 0.010 (MAX)
BISMUTH : 0.003 (MAX) PHOSPHORUS : 0.02 (MAX)
TIN : 0.30 (MAX) TOTAL : 0.75 (MAX)

KVD No. 63490

PILOT SAMPLE SHOULD BE APPROVED BY A H S P BEFORE BULK PRODUCTION

EST WT
0.012 Kg

TO BE STAMPED OR MARKED WHERE INDICATED THUS # LETTERS)

ALL SHARP EDGES AND CORNERS TO BE REMOVED UNLESS OTHERWISE STATED MACHINED CORNERS TO HAVE R OUT-SIDE R INSIDE EQUIVALENT CHAMFERS ARE PERMISSIBLE

8

7

6

			DRN	<i>None</i>	MATERIAL	USED ON: CB 20-15-665-5
			CHD	<i>None</i>	BRASS AC 59-1	CB 315-665
			TCD	<i>None</i>	GOST 15527-70	
			APPD	<i>None</i>	CONTROLLERATE OF INSPECTION (HEAVY VEHICLES)	
			DATE	08-5-'86	AVADI	
			SCALE	1 : 1	TITLE VARIABLE SPEED GOVERNOR LEVER BUSHING	
			DIMENSIONS	IN mm		
			TOLERANCE	ON DIMNS UNLESS OTHERWISE STATED		
			ALL THREADS TO	CONFORM TO	D S CAT NUMBER	DRAWING NUMBER
			ISSUE	DATE		315-636-1

A6

SIZE A3



DRAWING NUMBER
Cb.315-665-7

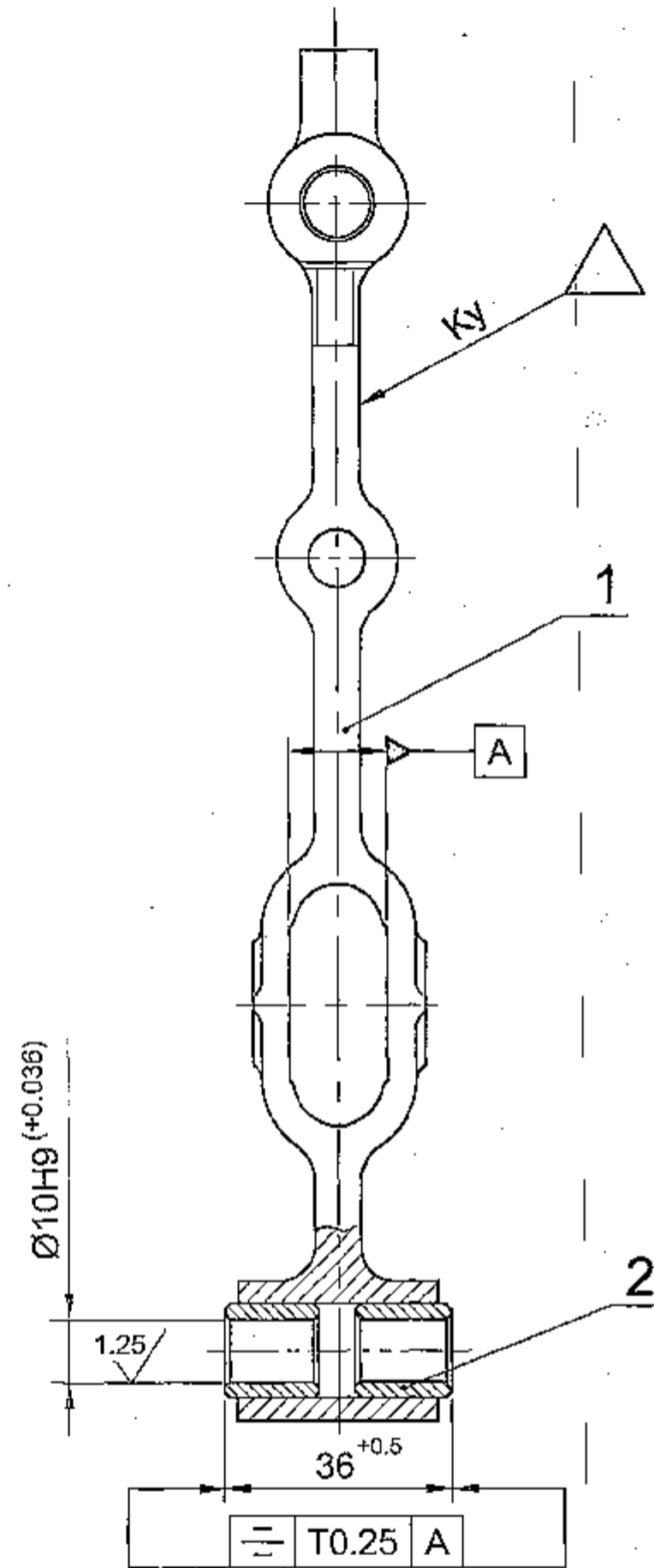

PILOT SAMPLE SHOULD BE APPROVED BY A H S P
BEFORE BULK PRODUCTION.

EST. WT. (Kg) 0.315	TO BE STAMPED OR MARKED WHERE INDICATED THUS # (LETTERS)
------------------------	---

ALL SHARP EDGES AND CORNERS TO BE REMOVED UNLESS
OTHERWISE STATED MACHINED CORNERS TO HAVE R OUT-
SIDE R INSIDE EQUIVALENT CHAMFERS ARE PERMISSIBLE.

DRN	CHD	APPD	DATE	SCALE:- 1:1	DIMENSIONS IN mm	TOLERANCE ON DIMNS UNLESS OTHERWISE STATED IS : 2102 - 69	ALL THREADS TO CONFORM TO	ISSUE	DATE	NATURE OF AMENDMENTS	
MATERIAL :-				USED ON :- CB 315-662-16				CONTROLLERATE OF QUALITY ASSURANCE (HEAVY VEHICLES) AVADI			
TITLE :- MAIN GOVERNOR LEVER ASSY.							D S CAT NUMBER		DRAWING NUMBER Cb.315-665-7		

DRAWING INDIANISED BASED ON RUSSIAN ORIGINAL ISSUE - 4

F-5
42
283
SIZE A2

