

THIS DOCUMENT AND THE INFORMATION CONTAINED IN IT ARE PROPRIETARY AND CONFIDENTIAL TO OFT. NO PERSON OR ENTITY IS ALLOWED TO COPY, REPRINT, REPRODUCE OR PUBLISH ANY PART OF THIS DOCUMENT, NOR DISCLOSE ITS CONTENTS TO OTHERS, NOR MAKE ANY USE OF IT, NOR ALLOW OR ASSIST OTHERS TO MAKE ANY USE OF IT UNLESS BY THE PRIOR WRITTEN EXPRESS AUTHORIZATION OF OFT AND THEN ONLY TO THE EXTENT AUTHORIZED.
COPYRIGHT-OFT.

NOTES:

- INTERPRET THIS DRAWING IAW ASME Y14.100M.
- MATERIAL: STEEL ALLOY BAR SAE 4130 PER SAE-AMS-S-6758 OR SAE 4340 PER SAE-AMS-S-5000. (EQUIVALENT MATERIAL IS PERMITTED AFTER ELBIT APPROVAL).
- HEAT TREATMENT: QUENCH AND TEMPER ENTIRE PART; HARDNESS 35±4 HRC. PER AMS 2579/1
- DEBURR AND REMOVE SHARP EDGES APPROX. 0.3X45°.
- GENERAL TOLERANCES ACCORDING TO ISO 2768-m.
- FINISH: DRY FILM LUBRICATION IN A FLUOROPOLYMER ORGANIC RESIN SOLVENT COLOR BLACK CLASS 2 TYPE I, 15±5 MICRON THICK
- BAKE PART AFTER PLATING WITHIN 3 HOURS per MIL-DTL-16232 TABLE I for 8 hours at 98°C to 107 °C.
- QUALITY ASSURANCE PROVISIONS: 8.1 QUALITY ASSURANCE PROVISIONS FOR THIS ITEM PER RDMQD00012P.
- PARENTHETICAL FIGURES ARE FOR REFERENCE ONLY.
- PACKAGING AND PACKING: THE FINISHED PART SHALL BE PRESERVED AND PACKAGED IN ACCORDANCE WITH COMMERCIAL PRACTICE.
- IDENTIFY PER MIL-STD-130 PARA 4.1.B, BY LABELING ITS CONTAINER WITH THE PART NUMBER. CHARACTERS MINIMUM TEXT HEIGHT 1.25 MM.

SHEET REV RECORD	
ALL SHEETS ARE THE SAME REVISION	

REVISION RECORD				
REV	ECO	DESCRIPTION	DATE	APVD
01		Freeze	01-Jan-14	
02		Restricted	06-Jan-14	
--	T00065	Identical To Previous Released	09-Apr-18	L. Goldshtein

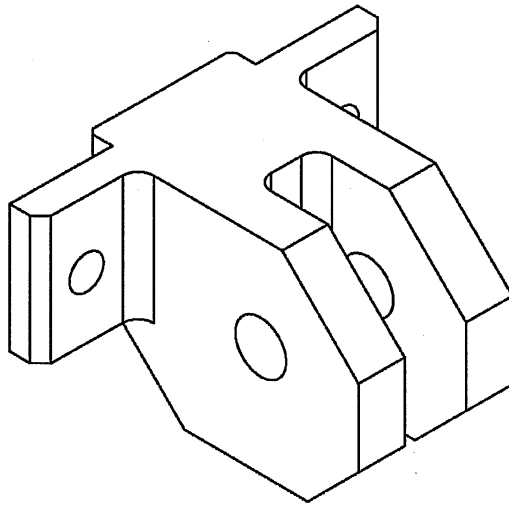
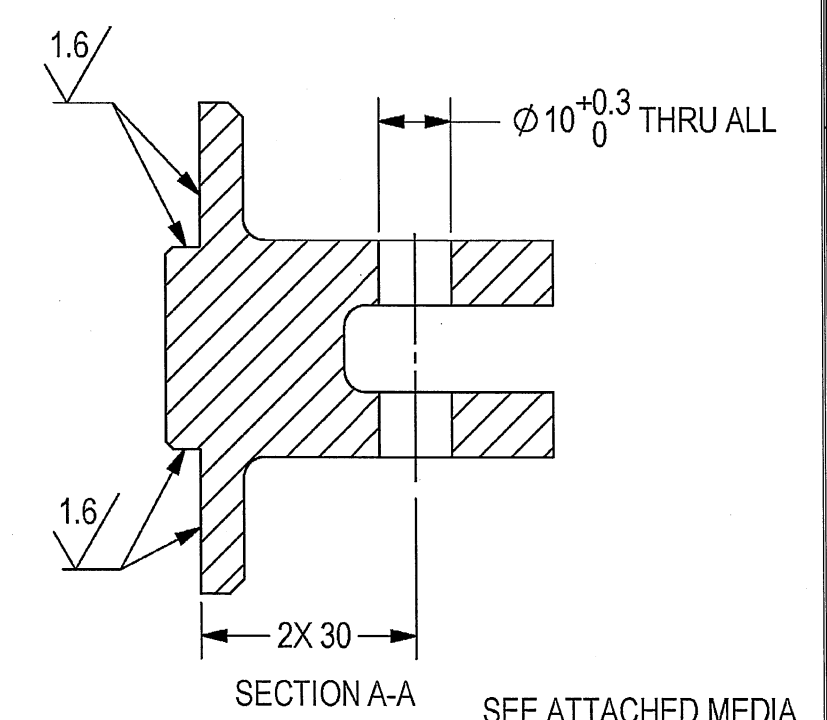
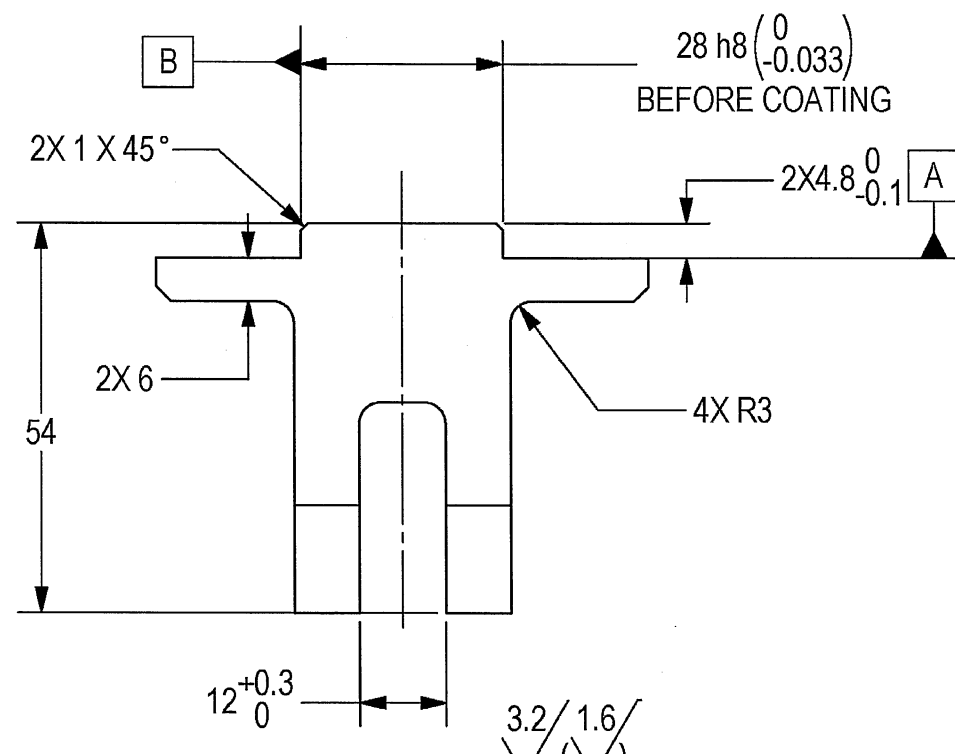
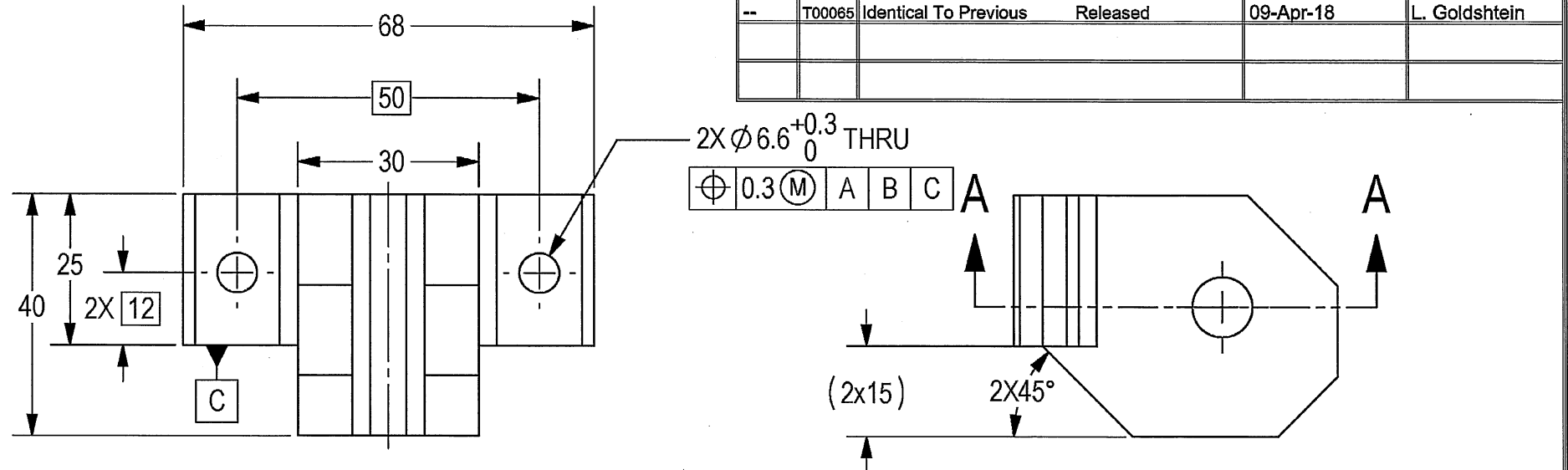

(WEIGHT APPROX.: 0.38 Kg.)

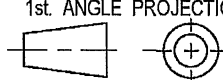
UNLESS OTHERWISE SPECIFIED		SIGNATURE	DATE	 ORDNANCE FACTORY TIRUCHIRAPPALLI	
DIMENSIONS ARE IN MM PER ASME Y14.5M -1994		DRAWN	11/9/20		
TOLERANCES		CHECKED		TITLE	
LINEAR	ANGULAR	HOS/DDO	P. Fortin 3/9/20	LIMITER EXTERNAL	
SEE NOTE 5	SEE NOTE 5	OFFICER/PRODN		FOR: PEDESTAL ASSY	
1st ANGLE PROJECTION		OFFICER/QC		OF: 12.7MM SRCG	
		OFFICER/DDO		SIZE	CAGE CODE
SURFACE TEXTURE IN Micro M				B	2291A
PROJECT OFFICER	PLM Control			DWG NO	075150A-00
				SCALE	1:1
				AUTOMATED DRAWING (SW)	SHEET 1 OF 1