

DRG. No. **AW2-23-1-411-0001**

ALL DIMENSIONS ARE IN MM UNLESS OTHERWISE STATED

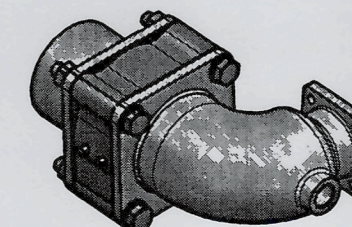

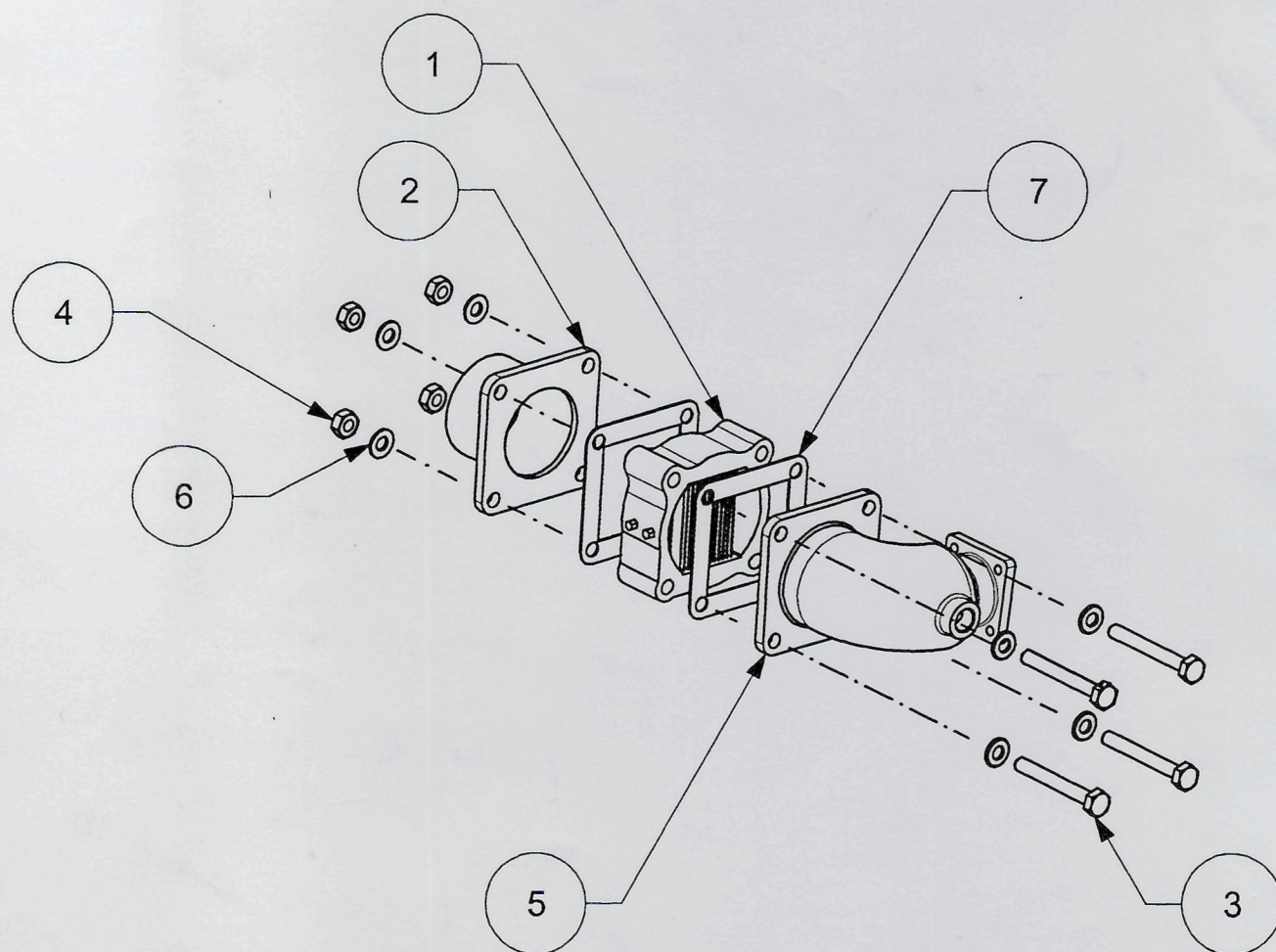

7	GASKET (CUMMINS PART NO.3969988)	2
6	WASHER 10.5 IS 2016-STEEL	8
5	AW2-23-1-411-0002 (AIR INLET)	1
4	PREVAILING TORQUE TYPE HEX NUT ISO 7040-M10-5	4
3	HEXAGON HEAD BOLT ISO 4014-M10X80-5.6	4
2	AW2-23-1-411-0005 (FLANGE)	1
1	AW2-23-1-411-0006 (GRID HEATER)	1
PC NO	PART NAME	QTY

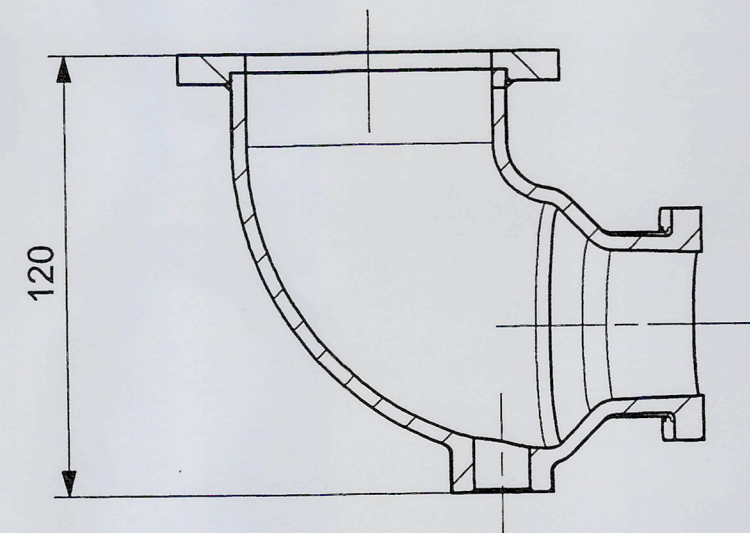
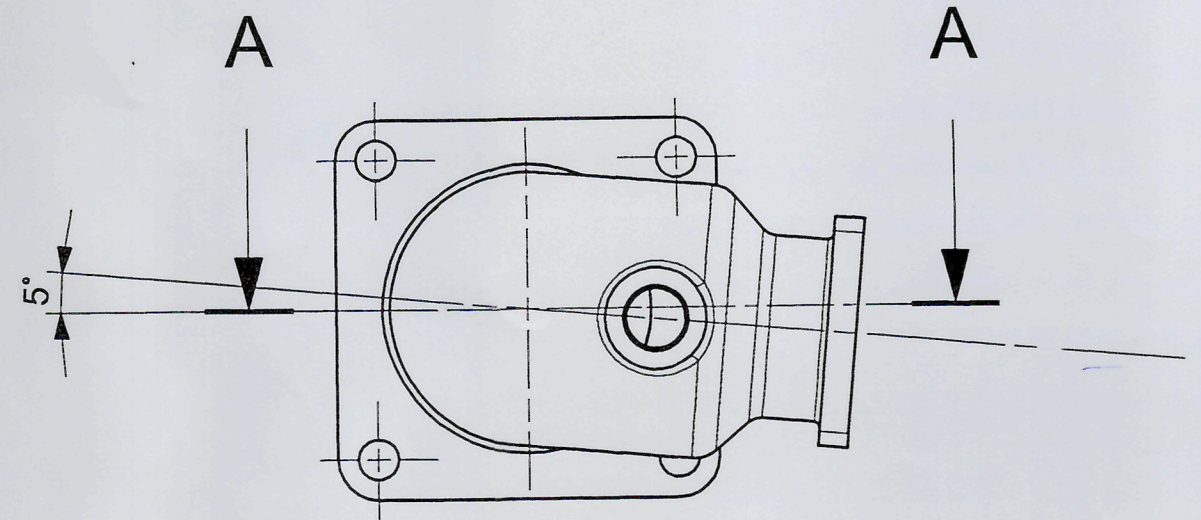
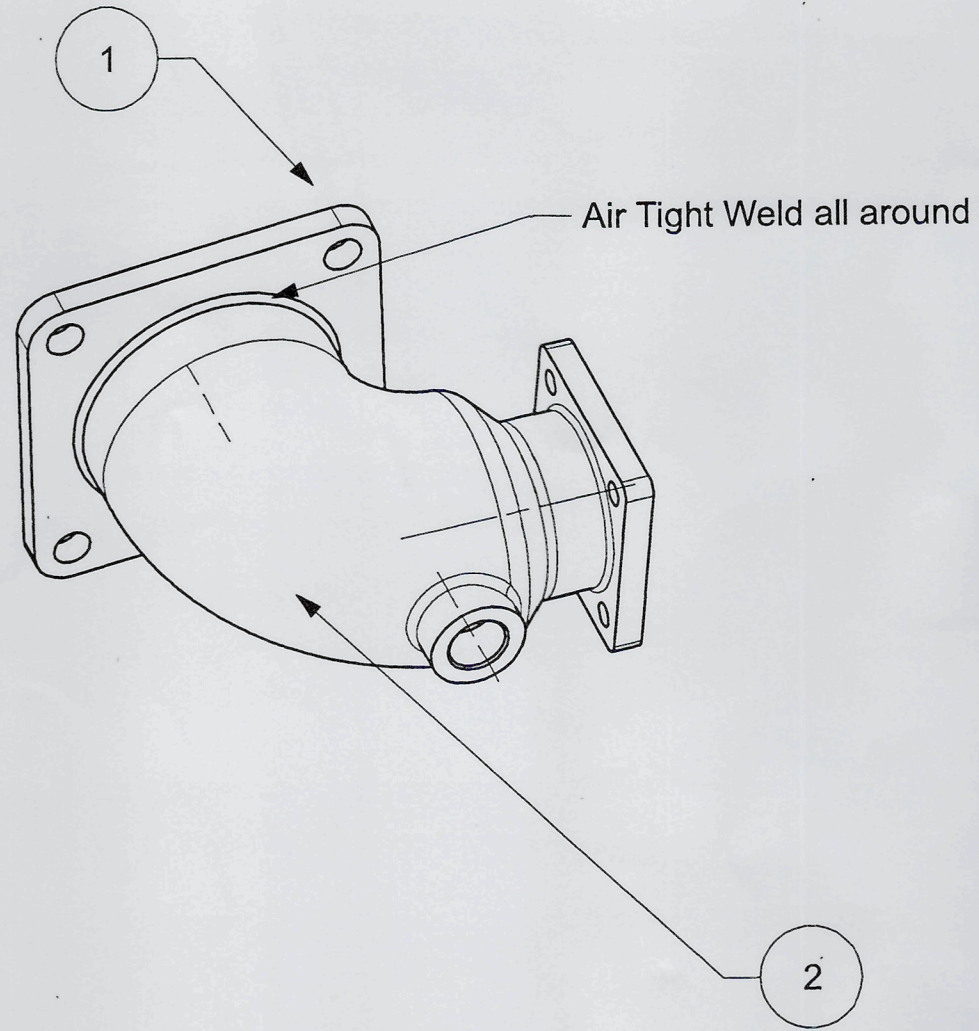
				GUN CARRIAGE FACTORY, JABALPUR			
		NAME	DATE	ASSY. No.		WEIGHT (K)	
		DRAWN	DK	03-08-2023	REF. DRG. No.	REF. ONLY	
		CHECKED			MATERIAL		
REV	AMENDMENTS	SIGN	DATE	APPROVED			
SURFACE TREATMENT		SCALE		NTS		Hot Air Starter Aid for M616	
GENERAL TOLERANCE ACCORDING TO IS 2102-1993						DRG. No. AW2-23-1-411-0001	SHEET 1 of 1



SECTION A-A

2	AW2-23-1-411-0003 (AIR INLET PIPE)	1
1	AW2-23-1-411-0004 (BRACKET AIR INLET)	1
PC NO	PART NAME	QTY

				 GUN CARRIAGE FACTORY, JABALPUR			
		NAME	DATE	ASSY. No.	WEIGHT (KG)		
		DRAWN	DK	03-08-2023	REF. DRG. No.		
		CHECKED			MATERIAL		
REV	AMENDMENTS	SIGN	DATE	APPROVED			
SURFACE TREATMENT		SCALE		NTS		Air Inlet	
GENERAL TOLERANCE ACCORDING TO IS 2102-1993						DRG. No.	AW2-23-1-411-0002
						SHEET	1 OF 1

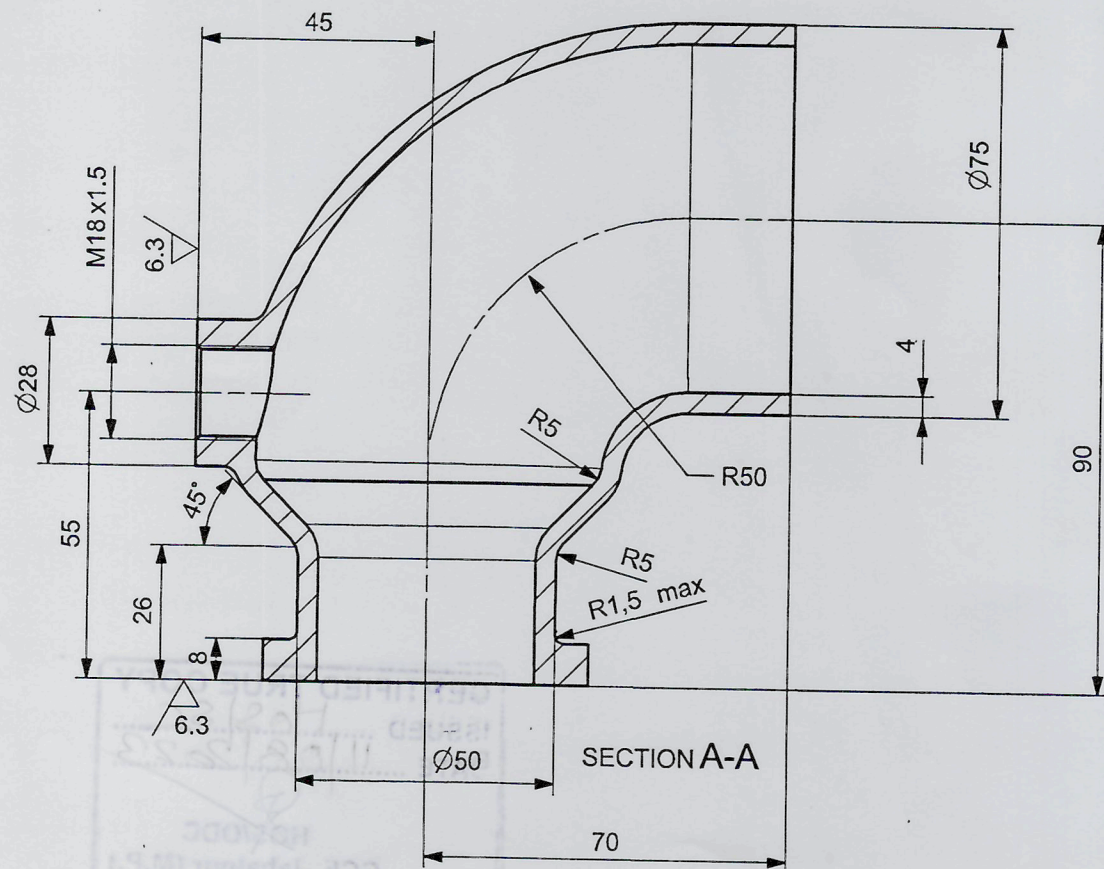
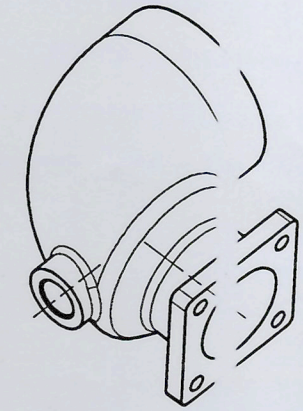
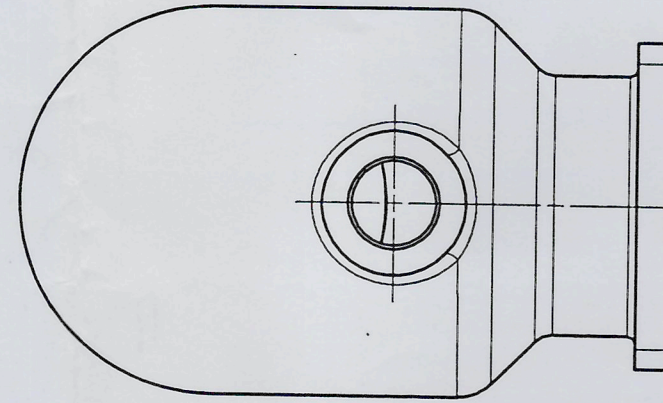
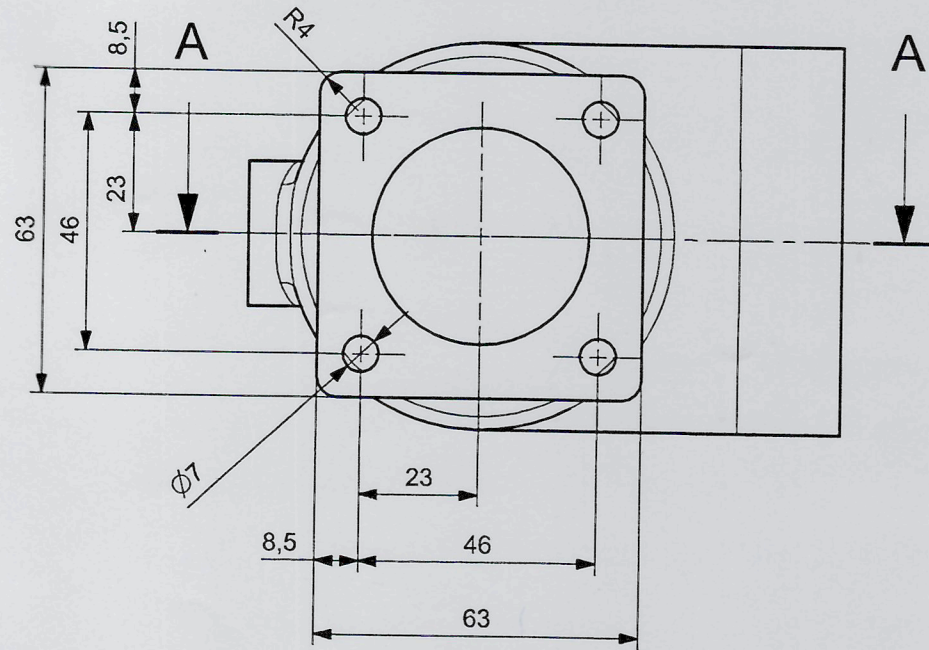

				GUN CARRIAGE FACTORY, JABALPUR			
		NAME	DATE	ASSY. No.	WEIGHT (KG) REF. ONLY		
		DRAWN	DK	03-08-2023	REF. DRG No.		
		CHECKED			MATERIAL	IS:73 394 Grade 65032 T6 OR I.A. 6061 T6	
REV	AMENDMENTS	SIGN	DATE	APPROVED			
SURFACE TREATMENT				SCALE	1:1		
GENERAL TOLERANCE ACCORDING TO IS 2102-1993						DRG. No.	AW2-23-1-411-0003
						SHEET	1 OF 1
						A2	

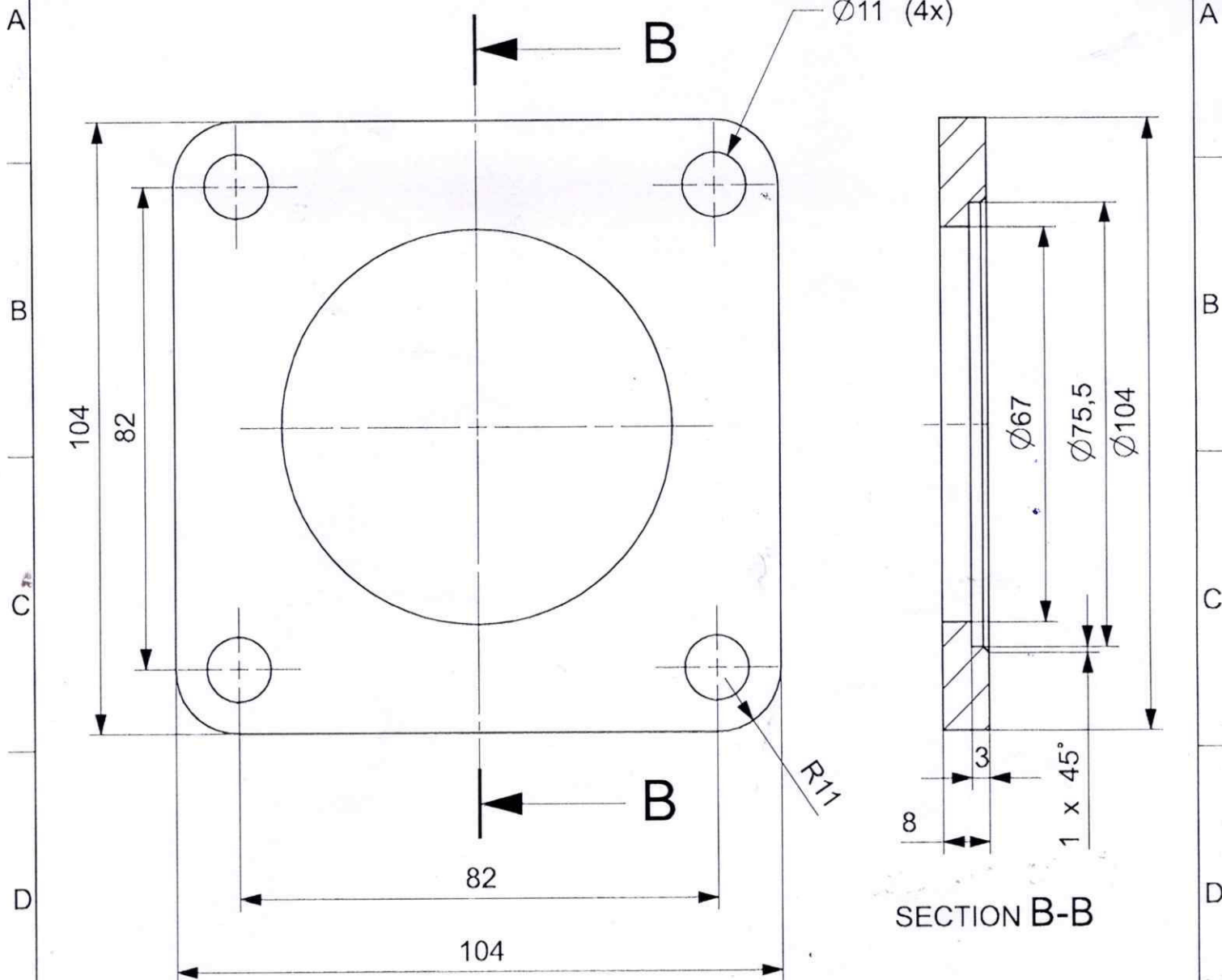

**GUN CARRIAGE FACTORY,
JABALPUR**

REV		AMENDMENTS	SIGN	DATE	APPROVED	NAME	DATE	ASSY. No.	WEIGHT (KG) REF. ONLY	
						DK	03-08-2023	REF. DRG. No.		
					CHECKED			IS:736-1994 Grade 65032 T6 OR A.A. 6061 T6		
								MATERIAL		
SURFACE TREATMENT				SCALE	NTS		Bracket Air Inlet			
GENERAL TOLERANCE ACCORDING TO IS 2102-1993							DRG. No.	AW2-23-1-411-0004	SHEET	1 OF 1

DRG. No. AW2-23-1-411-0005

ALL DIMENSIONS ARE IN MM UNLESS OTHERWISE STATED

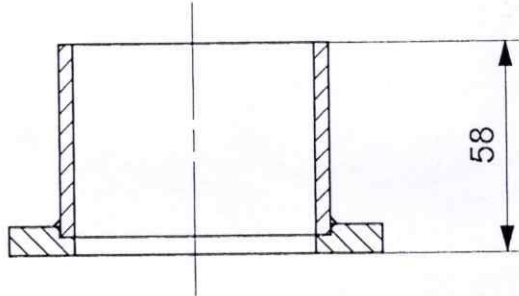

SECTION A-A

Air Tight Weld all around

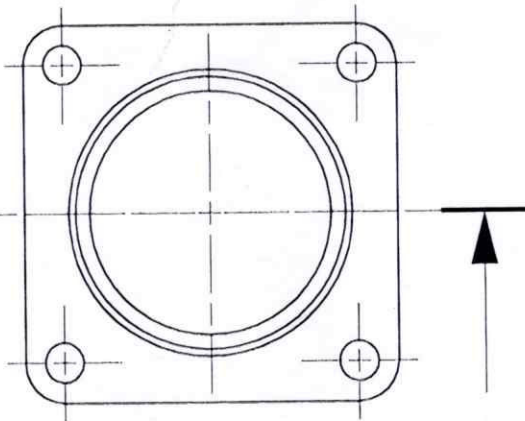
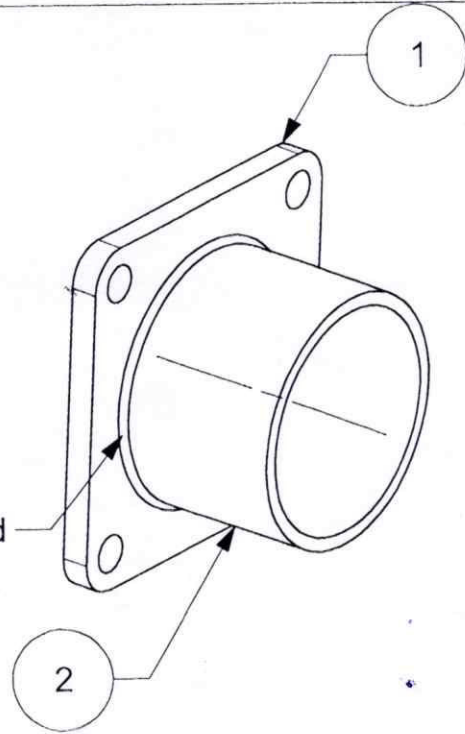

A

A

2	AW2-23-1-411-0007 (TUBE)	1
1	AW2-23-1-411-0004 (BRACKET AIR INLET)	1
PC NO	PART NAME	QTY



**GUN CARRIAGE FACTORY,
JABALPUR**

REV	AMENDMENTS	SIGN	DATE	APPROVED	NAME	DATE	ASSY. No.	WEIGHT (KG) REF. ONLY	
					DRAWN DK	03-08-2023	REF. DRG. No.		
					CHECKED		MATERIAL		
SURFACE TREATMENT				SCALE	Flange				
GENERAL TOLERANCE ACCORDING TO IS 2102-1993									
						DRG. No.	AW2-23-1-411-0005	SHEET	1 OF 1

1

2

3

4

DRG. No. AW2-23-1-411-0007

ALL DIMENSIONS ARE IN MM UNLESS OTHERWISE STATED

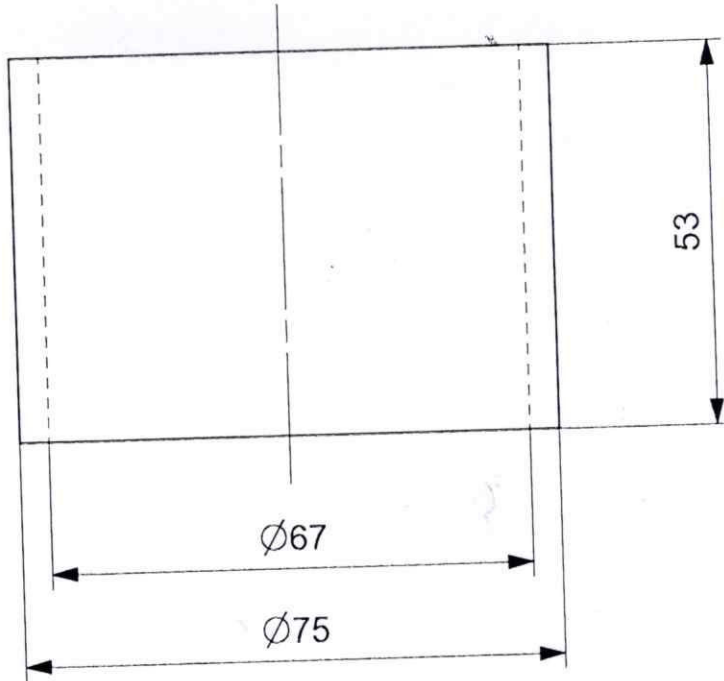

**GUN CARRIAGE FACTORY,
JABALPUR**

				NAME		DATE		ASSY. No.	
				DRAWN		DK		03-08-2023	
				CHECKED				REF. DRG. No.	
REV		AMENDMENTS		SIGN		DATE		APPROVED	
								MATERIAL	
								IS:738-1994 Grade 65032 T6 OR A.A. 6061 T6	
SURFACE TREATMENT				SCALE		NTS		Tube	
GENERAL TOLERANCE ACCORDING TO IS 2102-1993						DRG. No.		AW2-23-1-411-0007	
						SHEET		1 OF 1	