

069100-500  
D.S.CAT. NO.

1.02 x 45° CHAM.

DI MMS. ARE IN mm.

FOR EXPLANATION OF DIMENSIONING  
ETC. SEE D.D. NOTE SHEET NO.3 (LATEST  
ISSUE)

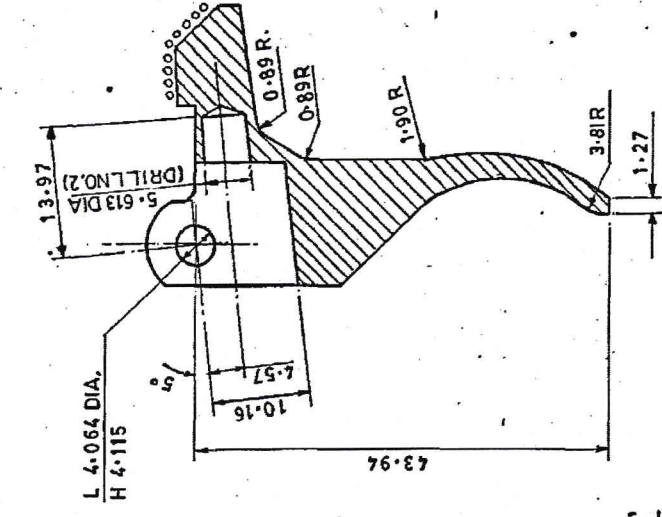
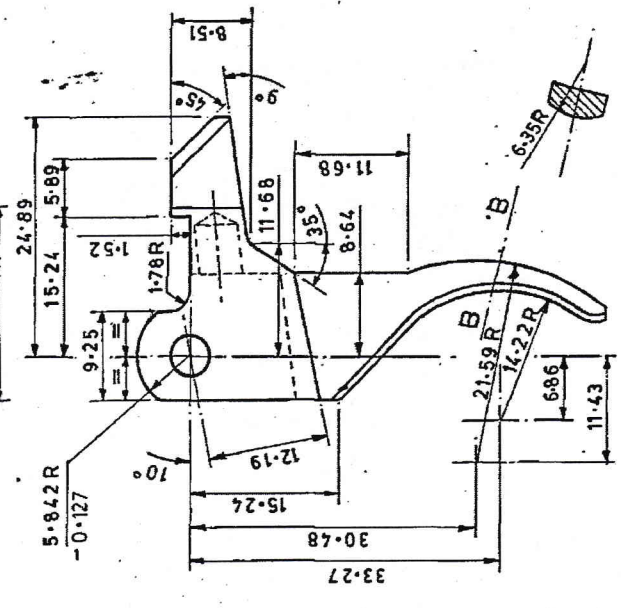
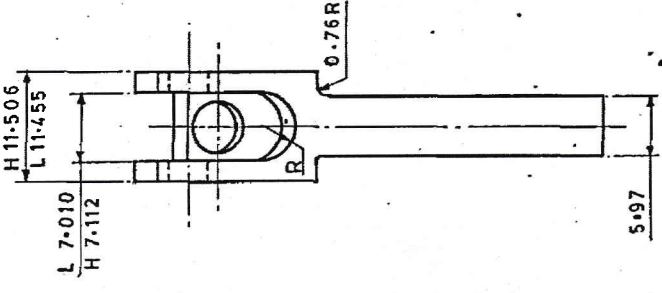

UN CONTROLLED COPY  
CERTIFIED CORRECT COPY OF APPROVED  
DRAWINGS AT THIS DATE: 28/12/21  
DESIGN & DRAWING OFFICE,  
ORDNANCE FACTORY, TIRUCHIRAPPALI-60016

ICR 1238

FINISH :-  
THUMB PORTION :- PHOSPHATE  
TO SPECN. JSS:0465-01:1988  
CLASS I PAINT REF FINISHING  
AMMUNITION STOVING BLACK  
SPRAYING FOR SMALL ARMS TO  
SPECN. JSS: 8010-37.  
REST PORTION :- PHOSPHATE  
TO SPECN. JSS:0465-01:1988  
CLASS I OIL FINISH.

NOTE :-  
FOR SPECN. LATEST ISSUE  
SHOULD BE FOLLOWED.

SECTION 'AA'

SECTION 'BB'

METRIC

23.031727044-SA	MATERIAL AMENDED	DRN. SCALE :- 2:1	TRD. Scaled COMP. APPROVED	AHSP CQA(SA), ICHA PUR
12-5-99 24361-SA	PROFORMA CHANGED & REDUCED, FINISH NOTE AMENDED, NEG. RE-TRACED AND DRG. RE-SCALED	CHD. <i>Ande</i>	EST. MASS	ASSY. 1005-001594, 1005-001595, 1005-001596
	PREVIOUS D.C. NOS. 14991-SA, 17584-SA, 17686-SA, 17760-SA & 18638-SA	DI. 12-5-99	NEG. RE-TRACED	DGR'S ARDE 657/283
DATE AUTHY.	BRIEF RECORD	<i>Ande</i> DAC	MATERIAL :- IS:5517-1993 DESIGNATION 55CB	PART NO.
SEALED :-	D.C. NO. 14991-SA, DT. 14.1.77	COPY	H.T / HARDNESS :- 0000 HARDNESS :- 400 - 475 H.V. REST OF THE BODY 24.0-2.60 H.V. (56-615 HRD)	DRG. NO.
NOMENCLATURE :-	TRIGGER	ZONE I/C/D.O. G.O. SIGN.	PROTECTIVE FINISH	D.S.CAT. NO. 1005-001690