

A A

Funktionsstärkrav
Medium: Luft
Tryck: 10 kPa övertryck
Temperatur: 20 °C
Tillåtet läckage: 890 mm³/s.

Requirements in imperviousness
Medium: Air
Pressure: 10 kPa over pressure
Temperature: 20 °C
Permitted leakage: 890 mm³/s

Häftsvetsad på fyra
Tackwelded in four

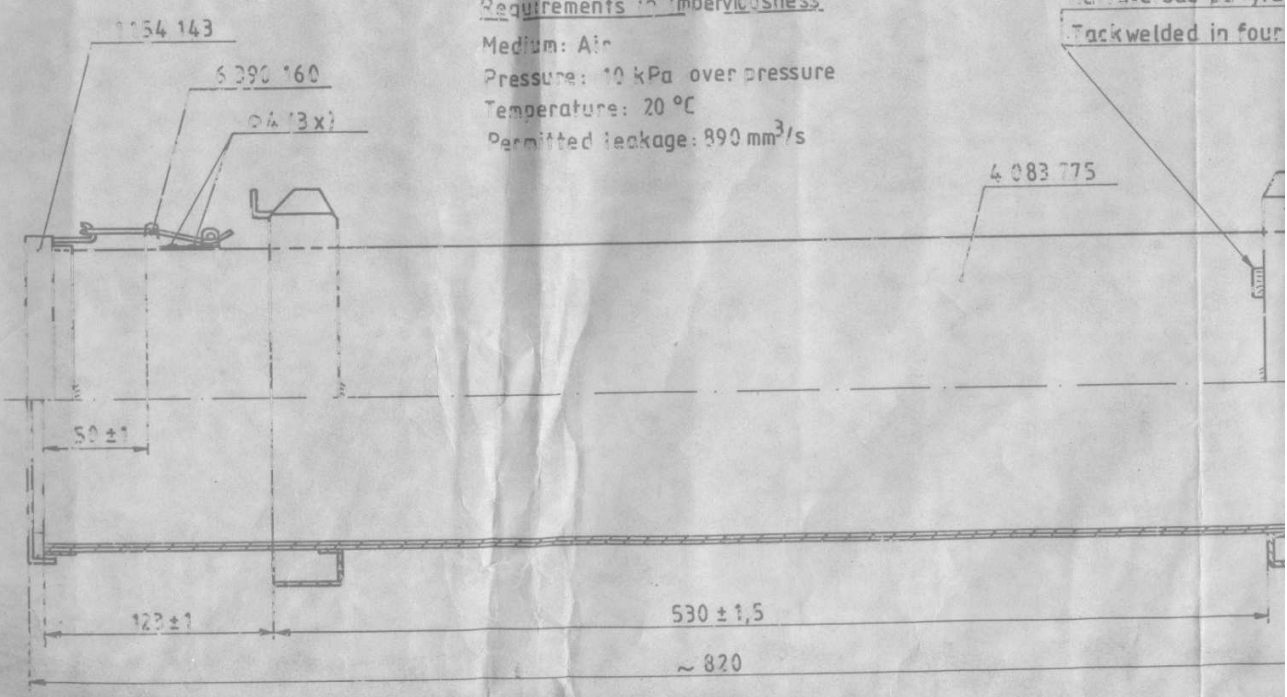

Scale 1:1

AFTER CLEANING AND INSPECTION THE METAL CONTAINER INCLUDING ALL STEEL FITTINGS WILL BE PHOSPHATED IN ACCORDANCE WITH SPEC. JSS 0465-01-1988 OR COATED WITH PRIME COAT OF PAINT READY MIXED QUICK DRYING MATT FINISH FOR GENERAL PURPOSE RED OXIDE (ISC 446 TO SPEC. IS:5-1978 REAFFIRMED IN 1991) CONFORMING TO SPEC. IS:168-1973 WITH AMENDMENT N° 3 (REAFFIRMED IN 1988) INTERNALLY AND EXTERNALLY, FOLLOWED BY A COAT OF PAINT OLIVE GREEN (ISC:220 TO IS:5-1978 REAFFIRMED IN 1991) TO SPEC. IS:168-1973 WITH AMENDMENT N° 3 (REAFFIRMED IN 1988) EXTERNALLY. METHOD OF APPLICATION FOR RED OXIDE AND PAINT OLIVE GREEN IS BY BRUSHING / SPRAYING / DIPPING.

Skala 1:
Scale 1:

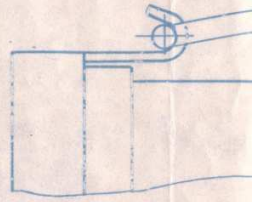

TESTING OF METAL CONTAINERS IS IN ACCORDANCE WITH SPEC. IA 1169 (n)

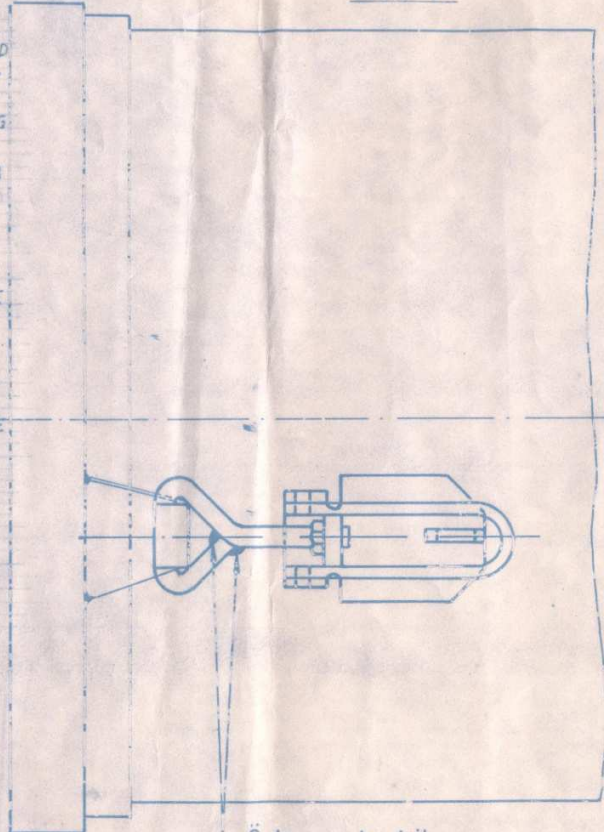

Ytbehandling:
Förbehandling V8-47
Målningsmetod Y4-25-9-600
Invändigt erfordras endast gr
Alternativ ytbehandling enligt

~~Surface treatment:
Pre-treatment V8-47
Painting method Y4-25-9-600
Inside only primer is required
Alternate surface treatment c~~

Öglan svetsad ihop
Loop welded together

T9 för köp 0 807 999
Technical specification 0 807

Op. nr. 4085561
Svarskort nr. 8

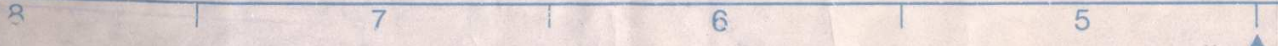

Toleranser enligt ISO		Tolerances acc. to ISO	
Basmått och tolerans		Gränsvärd	Limit deviation
Basic size and tolerance		ovre/upper	undre/lower

Typgodkännandemärkning
stämplas enl. 0 808 055
alternativ 014.

Package type approval stamped
in accordance with 0 808 055
alternative 014.

tällen. L=15mm
 places L=15mm.

4 099 622 (2x)

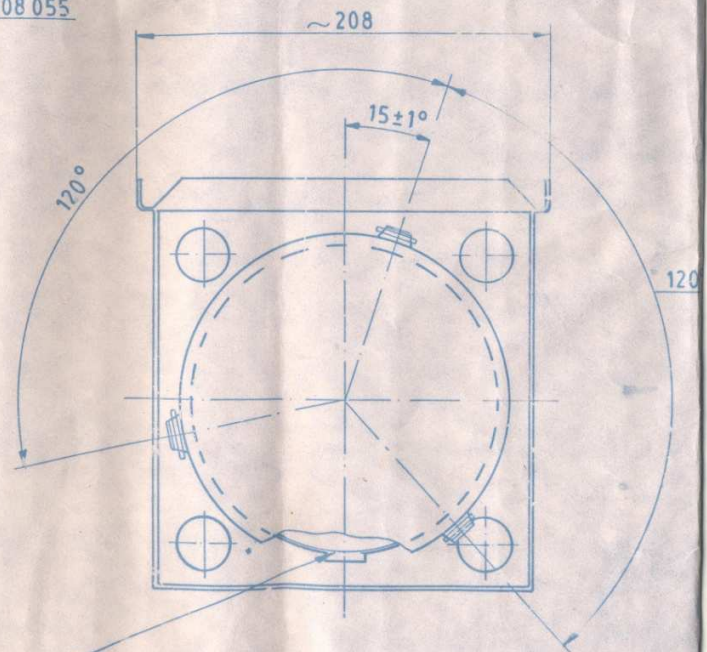
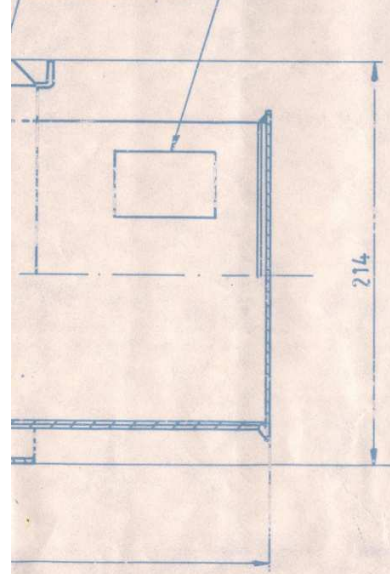

Placering av längsgående svets
Placing of longitudinal weld