

MATERIAL - IS 1109:84, Gr.3.	TREATMENT
SURFACE FINISH R=40	HARDNESS
	PROTECTIVE FINISH

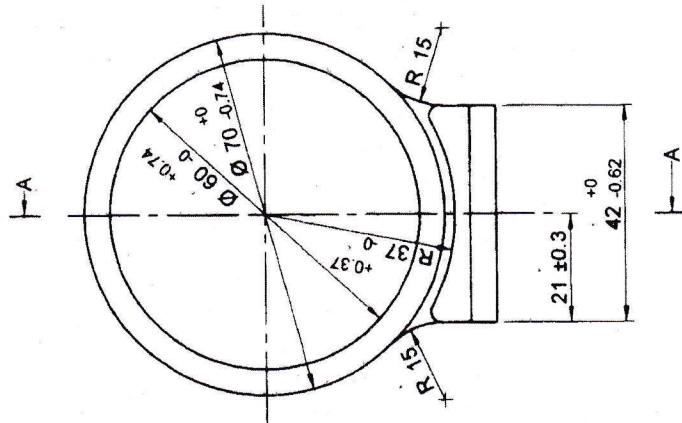
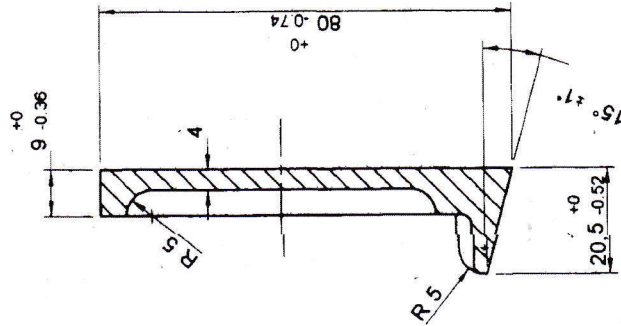

NOTES:-

1. INVESTMENT CASTING, CASTING OF GROUP I OCT 3- 4223-79.
2. CASTING ACCURACY 5-0-0-5 GOST 26645-85
3. UNSPECIFIED CASTING RADI R2 MAX.
4. PILOT SAMPLE SHOULD BE APPROVED BEFORE BULK SUPPLY.
5. FOR COMPONENT MACHINING SEE DRAWING No. 10- 73 34 605

*FOR BRADY COPY
Date of 10/09/06/2010
Ry*

ITEM DESCRIPTION		No. OFF	MATERIAL	REMARKS
2005		LIST OF PARTS		
COMPT. No.	ASSY. DRG.	OPTO ELECTRONICS FACTORY		
2005	GEN. TOL. IS 2102(M)	DEHRADUN		
DRAWN	9/1/05	TITLE		
CHD	2/1	HOLDER		
JWM	2/1	(CASTING)		
NAME	DATE	REF.		
DGMDOO	1/05	DRG. No. B23/IC/73.34.605/72		
APPROVED		SCALE:- 1 : 1		
AMENDMENTS		SHTS. 01		
DA No.	DESCRIPTION	ISH. No. 01		
22 P 5	DATE/SIGN	M 1		
41. 3/1/05	DRG. REVISED.			

34