

DRG. NO. SP-58

DIMENSIONS ARE IN mm.
 INFORMATION MARKED THUS '†' TO BE MARKED ON
 UNTOLERATED DIMENSIONS AS PER IS. 2102 (MEDIUM)

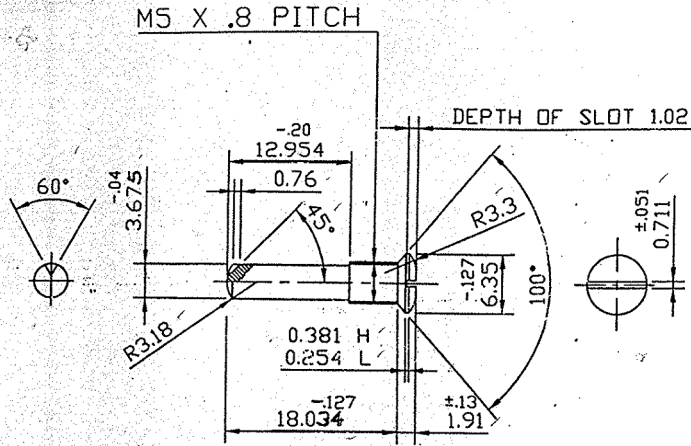

NOTE :- THE HEAD OF THE SCREW TO BE TURNED FROM
 THE WIRE OR BAR AND NOT SPUN OR SET UP.
 HEAD OF SCREW TO BE POLISHED BEFORE
 HARDENING OR PHOSPHATING

MATERIAL :- STEEL BS 970 PT.1-1983 070 M-55 (En-9)
 (HARDNESS :- 300-400 H.V.)

PROTECTIVE FINISH :- ~~PHOSPHATE TO SPECN. ISS 0465-01-1988~~
 CLASS-I OIL FINISH

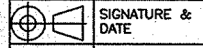
PART NO.	DESCRIPTIONS	NO OFF	MATERIAL	TREATMENT	REMARKS	
	 SIGNATURE & DATE TRACED DRAWN <i>[Signature]</i> CHECKED <i>[Signature]</i> OIC/D&DO <i>[Signature]</i> PRODN. OFFICER DIV. OFFICER D&DO				SUB: SCREW, SEAR FOR: OF: .315" SPORTING RIFLE DES. REF. NO: ^{SP-58} DS CAT No. 5305-005025 DRG. NO: 29 P 0058 ORDNANCE FACTORY TIRUCHIRAPALLI-16.	SCALE 2:1 STORE DRG. NO. OPERATION NO. SHEETS: SHEET NO:
AMENDMENTS	SIG. & DATE APPROVED ON:					