

UN CONTROLLED COPY

MATERIAL:- Steel Sheet 1.5mm

BS:1449 Pt-1 1983 Gr CS50

IS:2507-1975 Gr-2 55 C6

HARDNESS:- 320 - 380 HV

PROTECTIVE FINISH :- PHOSPHATED TO SPEC:

JSS:0465-01-1994 CLASS-II OIL FINISH.

CERTIFIED CORRECT COPY  
 OF APPROVED DRAWINGS  
 AT THIS DATE

*[Signature]*  
 Design & Drawing Office  
 Ordnance Factory,  
 Tiruchirappalli-620016

Qty/Gun :- 2-Nos.

AMENDMENTS	SIG. & DATE		SIGNATURE & DATE.	SUB: DETENT SHOULDER	SCALE NTS
		TRACED			
		DRAWN	<i>[Signature]</i> 7/8/20	OF: KALASHNIKOV MACHINE GUN(PKM)	Weight (g)
		CHECKED	<i>[Signature]</i>	DES. REF. NO.	REVISION
		OIC/D&DO	<i>[Signature]</i>	DRG. No.: PKM - 7212	
				DIV. OFFICER/D&DO	<i>[Signature]</i>
		APPROVED ON: 07.08.2020			SHEET No.: Sheet1



WIRE DIA : 1mm  
 OUTER DIA : 6.0 -0.2  
 WOUND : R.H.(OR)L.H.  
 No. OF EFFECTIVE COILS:  
 SOLID LENGTH : mm

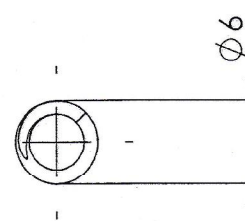
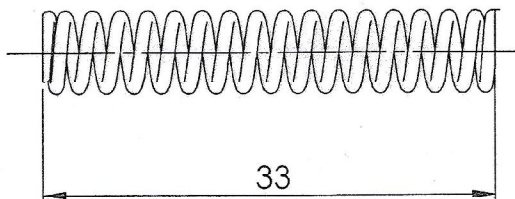

MATERIAL :- BS:5216:1975 Gr.5 Code 'M'

OR

IS:4454,Pt.1-2001 Gr.DH

PROTECTIVE FINISH :- PHOSPATED TO SPEC:  
 JSS:0465-01-1994 CLASS-II , OIL FINISH.

12 Hours Cramping for solid length.  
 Stress Relieve: 200 °C to 240 °C , 1Hr.

ONE COIL AT EACH END TO BE CLOSED AND GROUND  
 SQUARE TO THE AXIS OF THE COIL LEAVING 3/4  
 COIL AT EACH END NON -EFFECTIVE WOUND .

CERTIFIED CORRECT COPY  
 OF APPROVED DRAWINGS  
 AT THIS DATE .....

*[Signature]*  
 Design & Drawing Office  
 Ordnance Factory,  
 Tiruchirappalli-620016

UN CONTROLLED COPY

			SIGNATURE & DATE.	SUB: SPRING SHOULDER REST	SCALE NTS
		TRACED		FOR: BUTT PLATE ASSY	Weight (g)
		DRAWN	<i>[Signature]</i>	OF: PKM	REVISION
		CHECKED		DES.REF.NO.	
		OIC/D&DO	<i>[Signature]</i>	DRG. No.: PK - 7214	SHEETS: 1
OFFICER/PRD.N.		ORDNANCE FACTORY TIRUCHIRAPPALLI-16.	SHEET No.: Sheet1		
AMENDMENTS	SIG. & DATE	DIV.OFFICER/D&DO	APPROVED ON.		



B

C

D

E

F

A

B

C

D

E

F

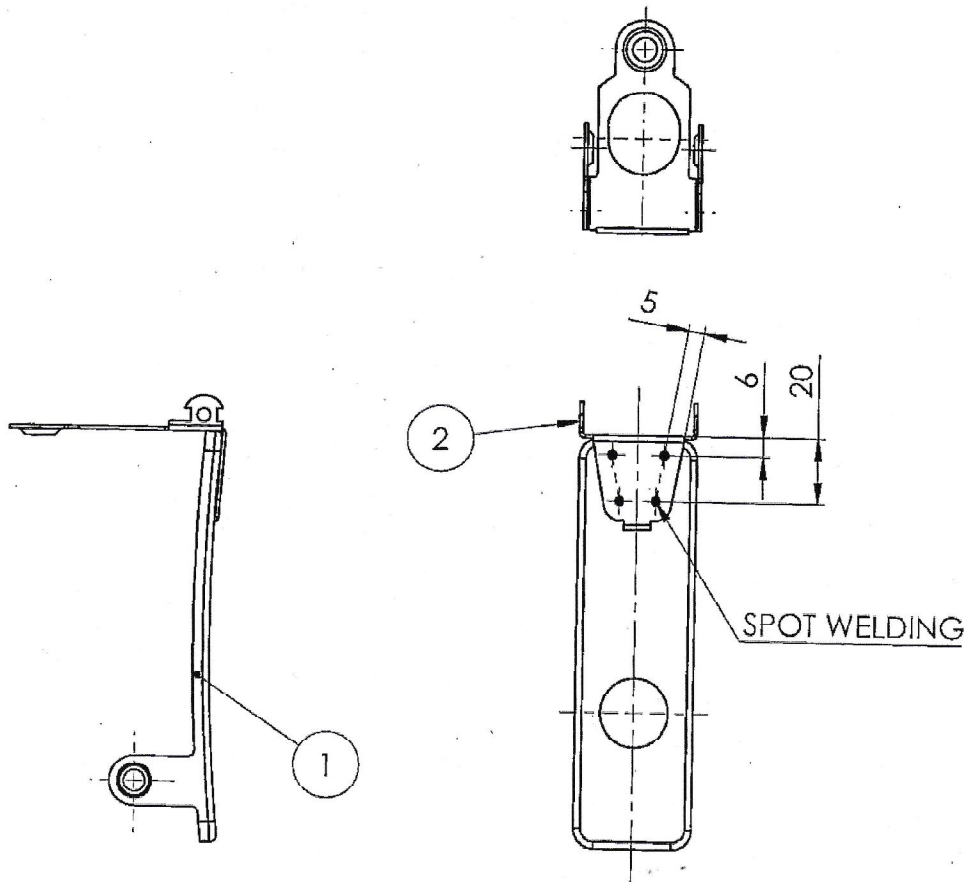

**NOTE :-**

SPOT WELDING TO BE MADE AS SHOWN IN DRG.

CERTIFIED CORRECT COPY  
OF APPROVED DRAWINGS  
AT THIS DATE

Design & 8/12/20  
Ordnance Factory,  
Tiruchirappalli-620016

ON CONTROLLED COPY

ITEM NO.	PART NUMBER	QTY.
1	PKM - 7221 BUTT PLATE	1
2	PKM - 7222 BRACKET SHOULDER REST	1

AMENDMENTS	SIG. & DATE		SIGNATURE & DATE.	SUB: BUTT PLATE WELD ASSY. FOR: BUTT ASSY(PKM-7200) OF: KALASHNIKOV MACHINE GUN(PKM)	SCALE
		TRACED			NTS
		DRAWN	8/8/20		Weight (g)
		CHECKED			REVISION
		OIC/D&DO			SHEETS: 1
		OFFICER/PRODN.		DRG. No.: PKM - 7220	SHEET No.: Sheet 1
		DIV.OFFICER/D&DO		ORDNANCE FACTORY TIRUCHIRAPPALLI-16.	
		APPROVED ON. 07.08.2020			



UNCONTROLLED COPY

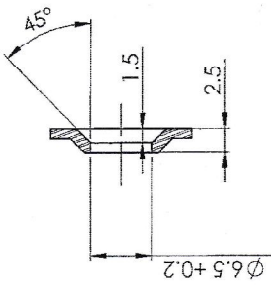

SECTION D-D  
SCALE 2:1

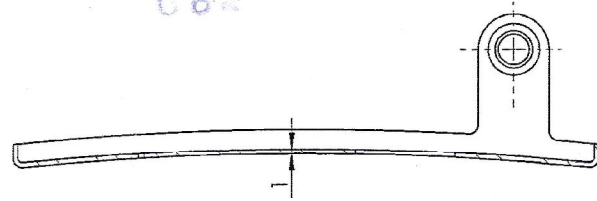
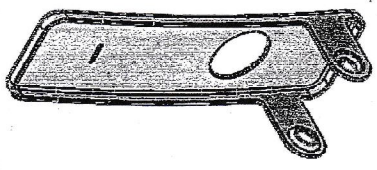

SECTION B-B

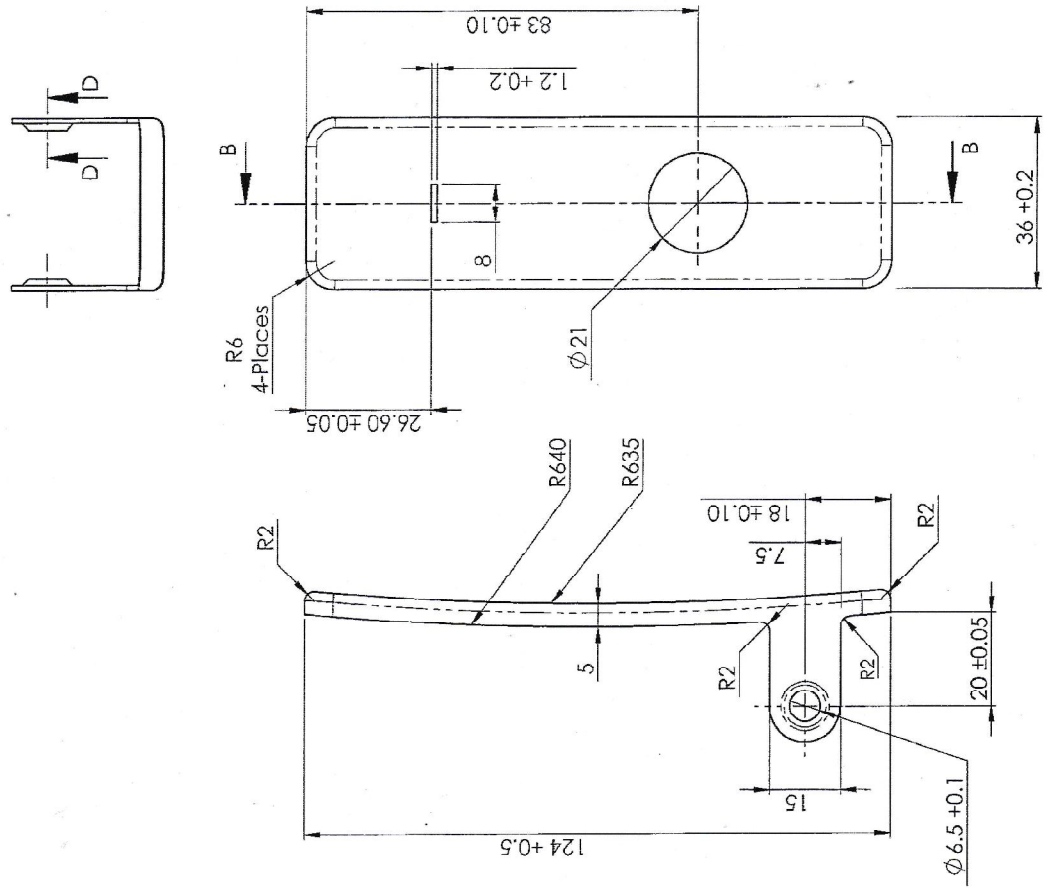

**MATERIAL:-** Steel Sheet 1mm  
**BS:** 1449 Pt-1 1983 Gr CS50  
**IS:** 2507-1975 Gr-2 55 C6  
**HARDNESS:-** 320 - 380 HV  
**PROTECTIVE FINISH:-** PHOSPHATED TO SPEC:  
**JSS:** 0465-01-1994 CLASS-II OIL FINISH.

Handwritten signature and date: 22/8/2020  
 Design & Drawing Office  
 Ordnance Factory,  
 Tiruchirappalli-620016

SIGNATURE & DATE:		SUE: BUTT PLATE		SCALE	
TRACED		FOR: BUTT PLATE WELD ASSY (PKM-7220)		NTS	
DRAWN	U 7/8/20	OF: KALASHNIKOV MACHINE GUN(PKM)		STORE DRG.NO.	
CHECKED		DES REF.NO.		OPERATION NO.	
HOSID&O OFFICER/PROJECT		DRG. No.: PKM - 7221		SHEETS: 1	
OFFICER/D&DO		ORDNANCE FACTORY TIRUCHIRAPPALLI-16.		SHEET No.: 1	
AMENDMENTS	SIG. & DATE	APPROVED ON: 07.08.2020			

DIMENSIONS ARE IN mm.  
 UNTOLERATED DIMENSIONS AS PER IS:2102(MED)

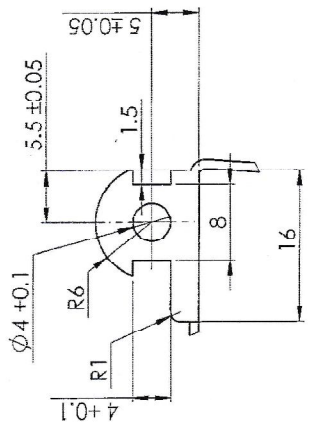
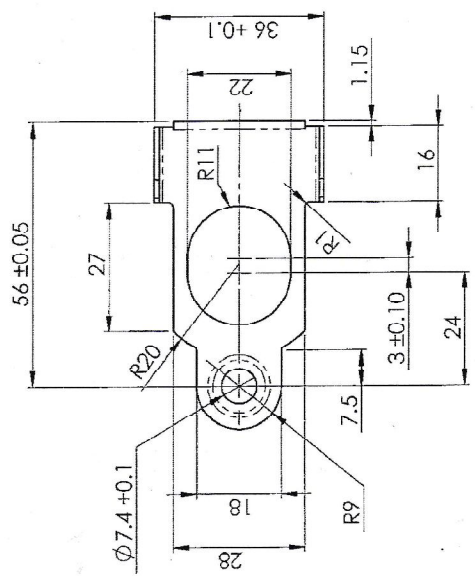

DETAIL B  
SCALE 2:1

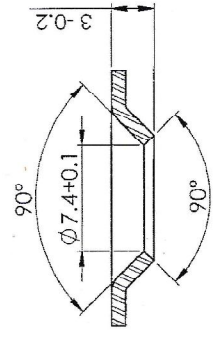
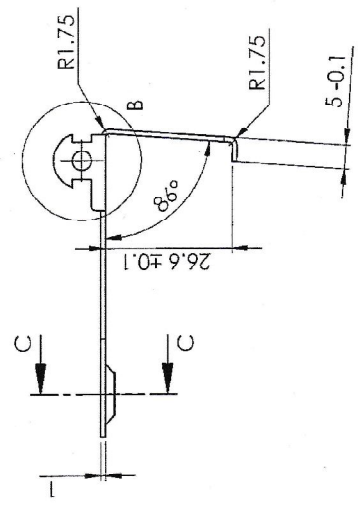
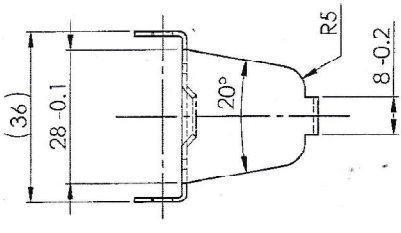
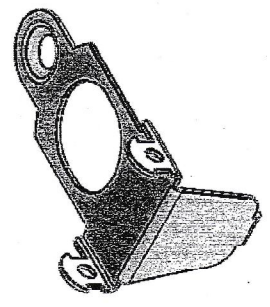

SECTION C-C  
SCALE 3:1

NON CONTROLLED COPY

MATERIAL:- Steel Sheet 1mm  
BS:1449 Pt-1 1983 Gr CS50  
IS:2507-1975 Gr-2 55 C6  
HARDNESS:- 320 - 380 HV

PROTECTIVE FINISH :- PHOSPHATED TO SPEC:  
JSS:0465-01-1994 CLASS-II OIL FINISH.

DIMENSIONS ARE IN mm.  
UNTOLERATED DIMENSIONS AS PER IS:2102(MED)

CERTIFIED CORRECT COPY  
OF APPROVED DRAWINGS  
AT THIS DATE *17/11/20*  
Design & Drawing Office  
Ordnance Factory,  
Tiruchirappalli-620016

TRACED	SIGNATURE & DATE	SUB: BRACKET SHOULDER REST	SCALE
DRAWN	<i>[Signature]</i> 7/8/20	FOR: BUTT PLATE WELD ASSY (PKM-7220)	NTS
CHECKED	<i>[Signature]</i>	OF: KALASHNIKOV MACHINE GUN(PKM)	STORE DRG.NO.
HOS/DADO	<i>[Signature]</i>	DES.REF.NO.	OPERATION NO.
OFFICER/PROJECT	<i>[Signature]</i>	DRG. No.:	SHEETS: 1
OFFICER/D&DO	<i>[Signature]</i>	PKM - 7222	SHEET No.: 1
SIG. & DATE	APPROVED ON. 07.08.2020	<b>FT</b> ORDNANCE FACTORY TIRUCHIRAPPALLI-16.	8

DRG NO. PK - 7230

DIMENSIONS ARE IN mm.  
 UNTOLERATED DIMNS. AS PER IS : 2102 (MED)

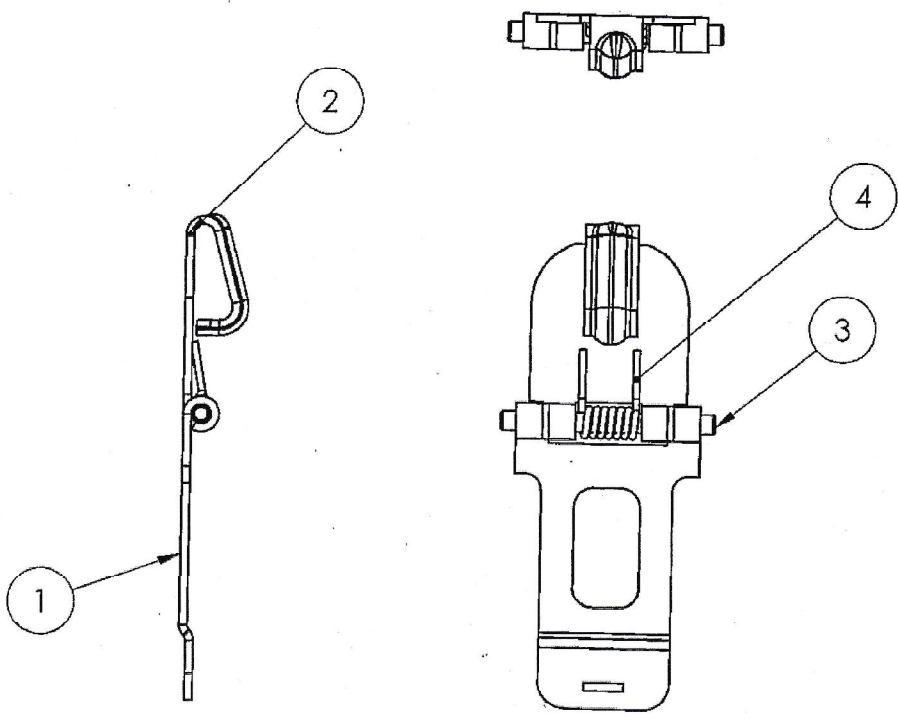

UN CONTROLLED COPY

CERTIFIED CORRECT COPY  
 OF APPROVED DRAWINGS  
 AT THIS DATE .....

*[Signature]*  
 Design & Drawing Officer  
 Ordnance Factory,  
 Tiruchirappalli-620016

ITEM NO.	PART NUMBER	QTY.
1	PKM - 7231 BUTT COVER PLATE	1
2	PKM - 7232 BUTT COVER	1
3	PKM - 7233 AXLE BUTT COVER PLATE	1
4	PKM-7234 HELICAL SPRING BUTT COVER ASSY	1

AMENDMENTS	SIG. & DATE		SIGNATURE & DATE.	SUB: BUTT COVER ASSY FOR: BUTT ASSY (PKM-7200) OF: KALASHNIKOV MACHINE GUN(PKM) DES. REF. NO. DRG. No.: PKM - 7230 ORDNANCE FACTORY TIRUCHIRAPPALLI-16.	SCALE NTS
		TRACED			Weight (g)
		DRAWN	<i>[Signature]</i> 8/8/20		REVISION
		CHECKED			SHEETS: 1
		OIC/D&DO	<i>[Signature]</i>		SHEET No.: Sheet1
APPROVED ON: 07.08.2020					



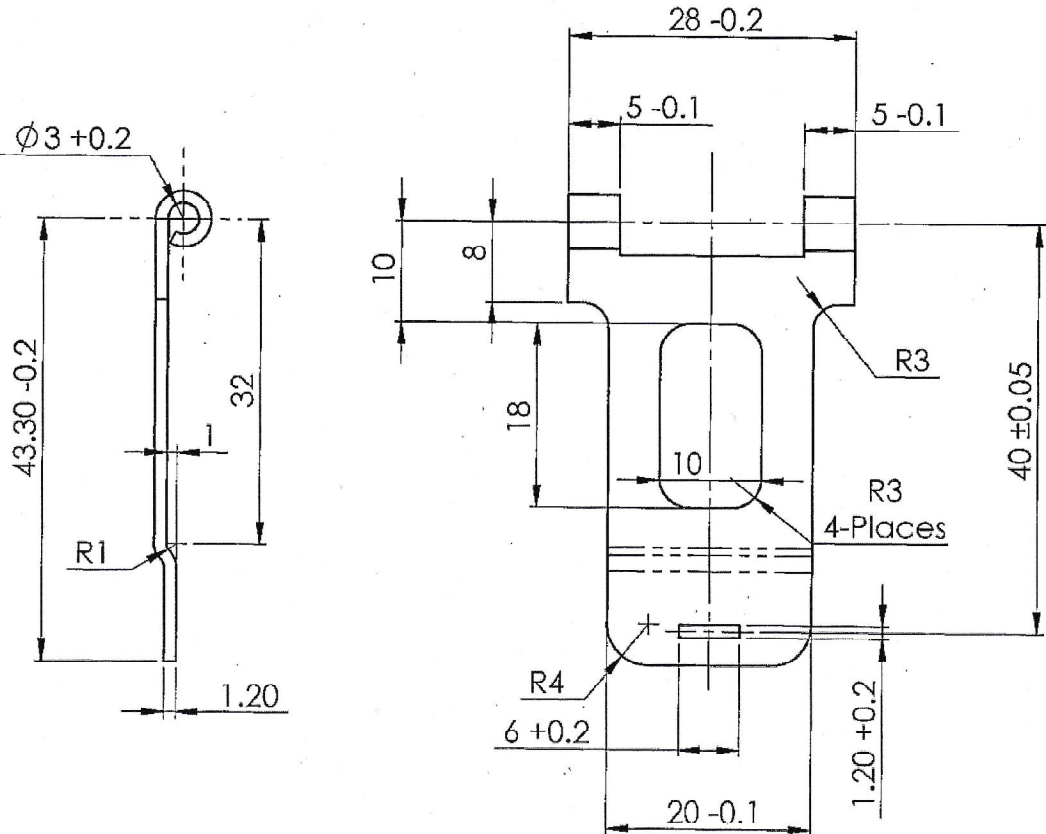

UN CONTROLLED COPY

CERTIFIED CORRECT COPY  
 OF APPROVED DRAWINGS  
 THIS DATE  
 [Signature]  
 Design & Drawing Office  
 Ordnance Factory,  
 Tiruchirappalli-620016

**MATERIAL:-** Steel Sheet 1mm  
**BS:**1449 Pt-1 1983 Gr CS50  
**IS:**2507-1975 Gr-2 55 C6  
**HARDNESS:-** 320 - 380 HV

**PROTECTIVE FINISH :-** PHOSPHATED TO SPEC:  
**JSS:**0465-01-1994 CLASS-II OIL FINISH.

AMENDMENTS	SIG. & DATE		SIGNATURE & DATE.	SUB: BUTT COVER PLATE	SCALE NTS
		TRACED		FOR: BUTT COVER ASSY (PKM-7230)	Weight (g)
		DRAWN	<i>Uk</i> 7/2/20	OF: KALASHNIKOV MACHINE GUN(PKM)	
		CHECKED	<i>Jan</i>	DES. REF. NO.	REVISION
		OIC/D&DO	<i>P. For</i>	DRG. No.: PKM - 7231	
		OFFICER/PRODN.		ORDNANCE FACTORY TIRUCHIRAPPALLI-16.	
DIV.OFFICER/D&DO	<i>SK</i>	SHEET No.: Sheet 1			
		APPROVED ON: 07.08.2020			

DRG. NO. PKM - 7232

DIMENSIONS ARE IN mm.  
 UNTOLERATED DIMNS. AS PER IS : 2102 (MED)

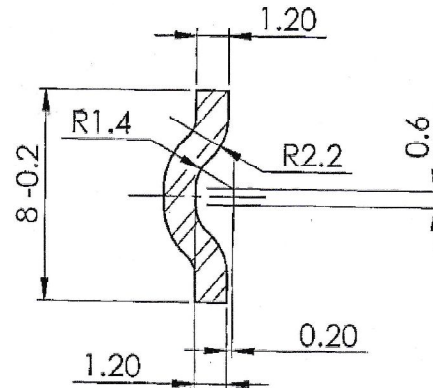
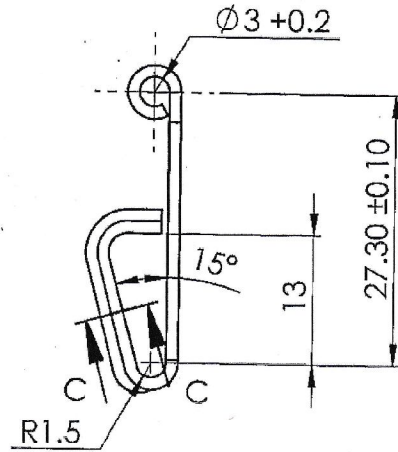
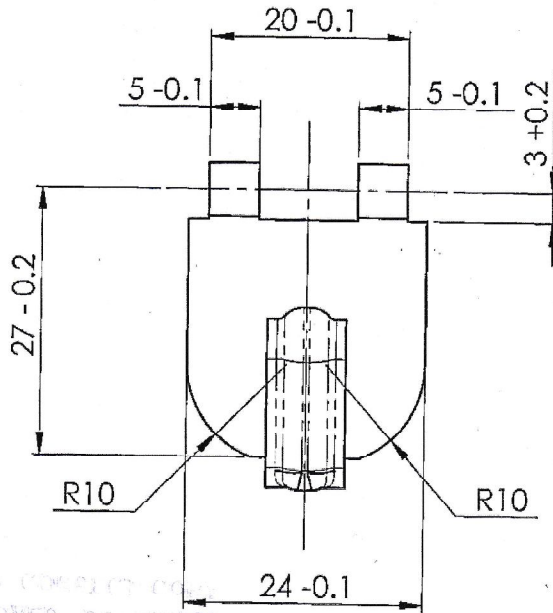
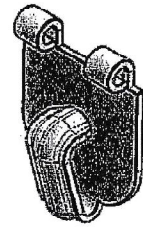

APPROVED DRAWINGS  
 8/12/20  
 Ordnance Factory,  
 Tiruchirappalli-620016

**MATERIAL:-** Steel Sheet 1.2mm  
 BS:1449 Pt-1 1983 Gr CS50  
 IS:2507-1975 Gr-2 55 C6  
**HARDNESS:-** 320 - 380 HV

**PROTECTIVE FINISH :-** PHOSPHATED TO SPEC:  
 JSS:0465-01-1994 CLASS-II OIL FINISH.

SECTION C-C  
 SCALE 4 : 1

AMENDMENTS	SIG. & DATE		SIGNATURE & DATE.	SUB: BUTT COVER	SCALE NTS
		TRACED		FOR: BUTT COVER ASSY (PKM-7230)	Weight (g)
		DRAWN	<i>Var</i> 7/8/20	OF: KALASHNIKOV MACHINE GUN (PKM)	REVISION
		CHECKED	<i>JM</i>	DES. REF. NO.	SHEETS: 1
		OIC/D&DO	<i>P. T. M.</i>	DRG. No.: PKM - 7232	SHEET No.: Sheet 1
		DIV. OFFICER/D&DO	<i>S. K. M.</i>	ORDNANCE FACTORY TIRUCHIRAPPALLI-16.	
APPROVED ON: 07.08.2020					

DRG NO. PKM - 7233

DIMENSIONS ARE IN mm.  
UNTOLERATED DIMNS. AS PER IS : 2102 (MED)

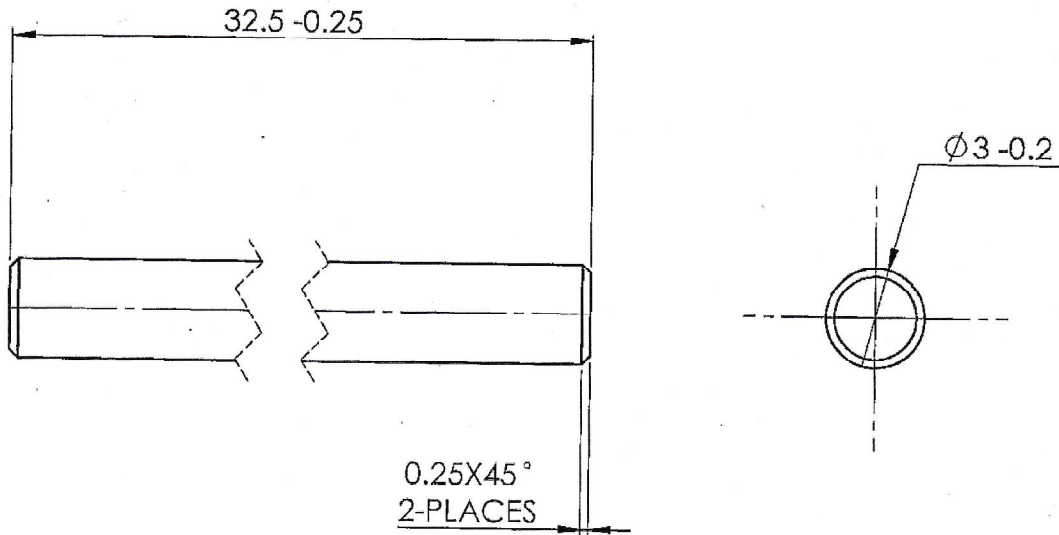

MATERIAL :- SPRING STEELS

IS:4454 Pt-1:2001 GR DH (OR)  
BS:5216-1975 SEC 3 CODE ND GR 3 (OR)  
BS:5216-1975 SEC 4 CODE M GR 5



ALT. MATERIAL :- CARBON SPRING STEELS

BS:970 Pt-5 1972 ,070 A72 (OR)  
BS:970 Pt-5 1972 ,070 A78 (OR)  
En-42 (OR) En-42G (OR) En-42J

HARDNESS :- 370 - 430 HV

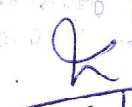
UN CONTROLLED COPY

  
 8/12/20  
 Drawing Officer  
 Ordnance Factory,  
 Tiruchirappalli-620016.

AMENDMENTS	SIG. & DATE		SIGNATURE & DATE.	SUB: AXLE BUTT COVER PLATE	SCALE
		TRACED		FOR: BUTT COVER ASSY (PKM-7230)	NTS
		DRAWN	<i>Ch</i> 8/8/20	OF: KALASHNIKOV MACHINE GUN(PKM)	Weight (g)
		CHECKED	<i>[Signature]</i>	DES. REF. NO.	REVISION
		OIC/D&DO	<i>P. Fox</i>	DRG. No.: PKM - 7233	SHEETS: 1
		OFFICER/PRODN.		 ORDNANCE FACTORY TIRUCHIRAPPALLI-16.	SHEET No.: Sheet 1
		DIV. OFFICER/D&DO	<i>[Signature]</i>		
		APPROVED ON: 07.08.2020			



DRG. NO. PKM - 7234

DIMENSIONS ARE IN mm.

UNTOLERATED DIMNS. AS PER IS : 2102 (MED)

WIRE DIA : 1mm

INNER DIA : 3 +0.8

WOUND : R.H.(OR)L.H.

No. OF EFFECTIVE COILS: 5

No. OF COILS: 7

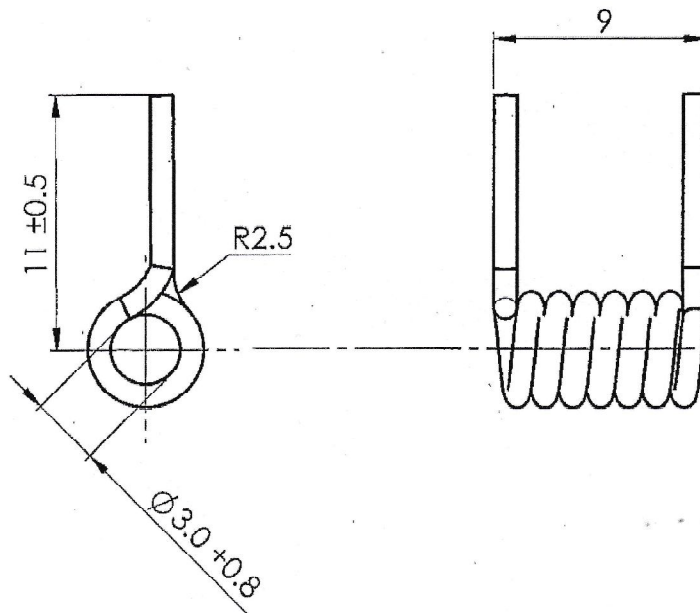

UN CONTROLLED COPY

CERTIFIED CORRECT COPY  
OF APPROVED DRAWINGS  
AT THIS DATE

Design & Drawing Office  
Ordnance Factory,  
Tiruchirappalli-620012

MATERIAL :- BS:5216:1975 Gr.5 Code 'M'

OR

IS:4454,Pt.1-2001 Gr.DH

PROTECTIVE FINISH :- PHOSPATED TO SPEC:

JSS:0465-01-1994 CLASS-II , OIL FINISH.

CRAMP TEST :- The spring to be compressed for a period of  
12 Hours before gauging .

Stress Relieve: 200 °C to 240 °C , 1Hr.

AMENDMENTS	SIG. & DATE		SIGNATURE & DATE.	SUB: SPRING HELICAL TORSION	SCALE NTS
		TRACED		FOR: BUTT COVER ASSY (PKM-7230)	Weight (g)
		DRAWN		OF: KALASHNIKOV MACHINE GUN(PKM)	REVISION
		CHECKED		DES. REF. NO.	
		OIC/D&DO		DRG. No.: PKM - 7234	SHEETS: 1
		OFFICER/ PRDN.		ORDNANCE FACTORY TIRUCHIRAPPALLI-16.	SHEET No.: Sheet1
DIV.OFFICER/ D&DO					
APPROVED ON: 14.09.20					