

1 2 3 4

ISS C V AA S SS IC DRG.No.

0 2 0 4 0 4 0 3 0 0 0 2 0 0 5 0 0 D A

GEN TOL FINE/MEDIUM/COARSE  
CLASS TO IS:2102

DRG CONVENTIONS CONFIRM TO INDIAN STDS.  
DIMN IN mm UNLESS OTHERWISE STATED

**CONTROL COPY No.**

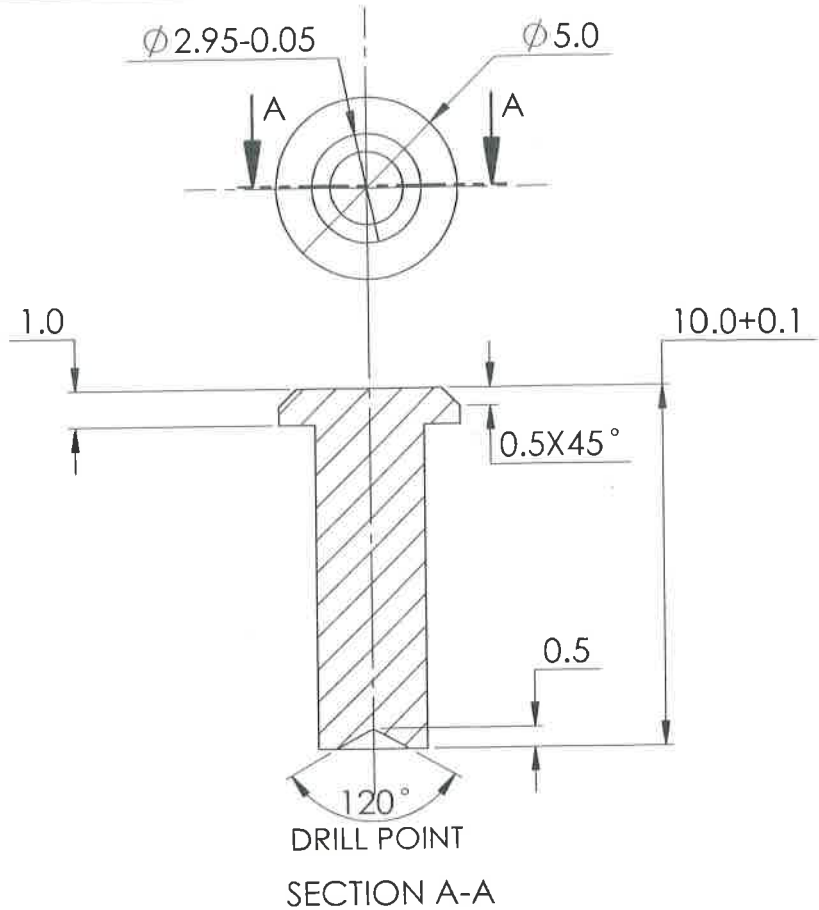

NOTES:

- 1) REMOVE ALL SHARP EDGES AND BURRS.
- 2) HARDNESS: 300-350HV
- 3) ALT. PROTECTIVE FINISH: Ni-PTFE, 20µm THICKNESS.

SR No	DATE	AUTHORITY	BRIEF RECORD	ZONE	CD	GO
DRN	SD	CHD	MATERIAL	SIGN		
APPD	DATE	DATE	STEEL TO IS: 5517:1993,Gd-55C8 (EN-9)			
SEALED	DATE	For Director	PROTECTIVE FINISH			
SCALE	5:1	EST MASS	PHOSPHATED TO SPECN IS:3618-1966, CLASS B			
DESIGN AUTHORITY	TITLE		PIN HINGE HOOK SLING			
ARDE	PUNE 411021					
DRG.No.	IC	SS	S	AA	A	C
PART No	DS CAT No		AHSP			

1 2 3 4