

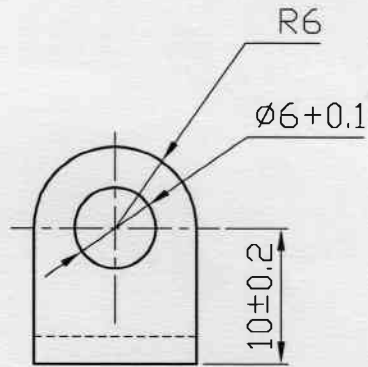

DIMENSIONS ARE IN mm.
 UNTOLERATED DIMNS. AS PER IS : 2102 (MED)

CERTIFIED CORRECT COPY
 OF APPROVED DRAWINGS
 AT THIS DATE
 31-1-15
 Design & Drawing Office
 Ordnance Factory
 Tiruchirappalli-600045

UN CONTROLLED COPY

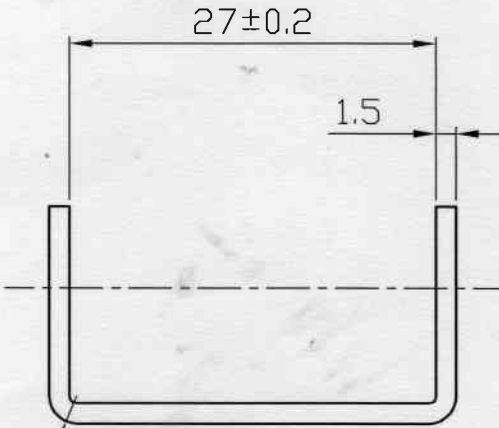
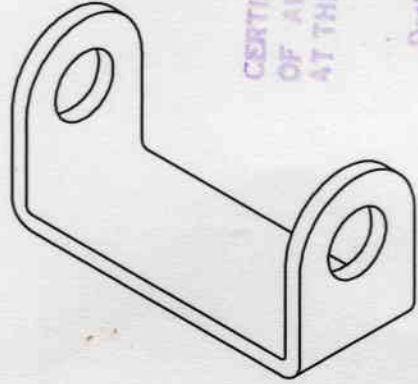
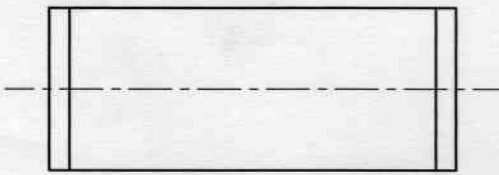

MATERIAL: BS/S-535 OR 15CDV6
 HARDNESS: 300 TO 350 VPN

PART NO.	DESCRIPTIONS	NO OFF	MATERIAL	TREATMENT	REMARKS
 TRACED DRAWN CHECKED HOS/D&DO OFFICER/ PRODN. OFFICER/ D&DO	SIGNATURE & DATE.	SUB: BRACKET SLING			SCALE
		FOR: AMMUNITION BOX			NTS
		OF : AGS 30			STORE DRG.NO.
		DES.REF.NO. GL 30 383			OPERATION NO.
		DRG. No.: 45P 5025			SHEETS: 1
		 ORDNANCE FACTORY TIRUCHIRAPPALLI-16.			SHEET No.: 1
AMENDMENTS	SIG. & DATE	APPROVED ON.	01.01.2015		