

D. A. NO.

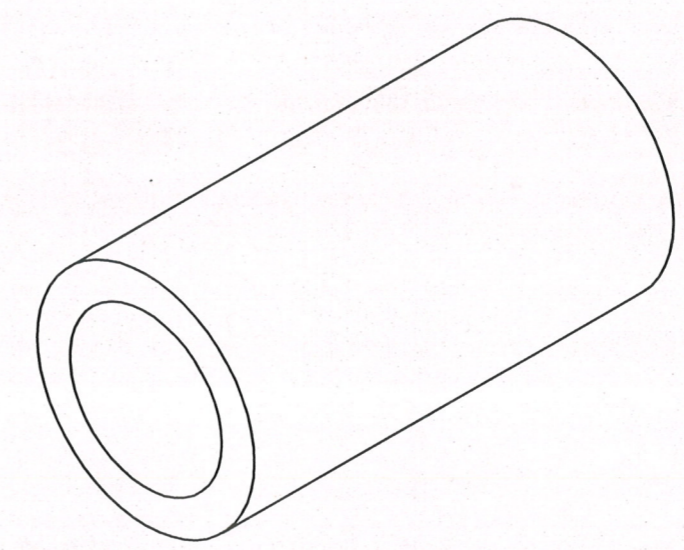
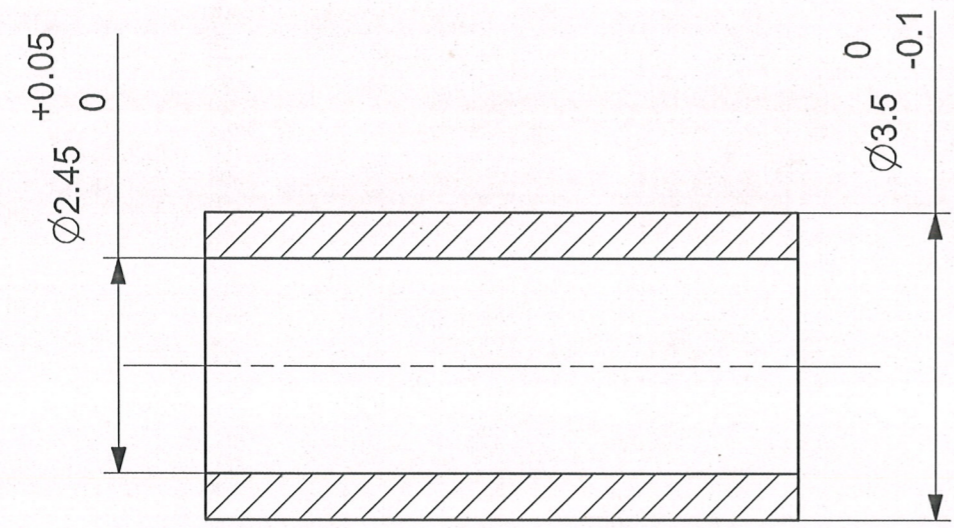
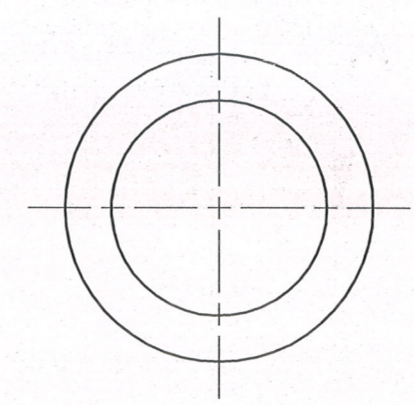
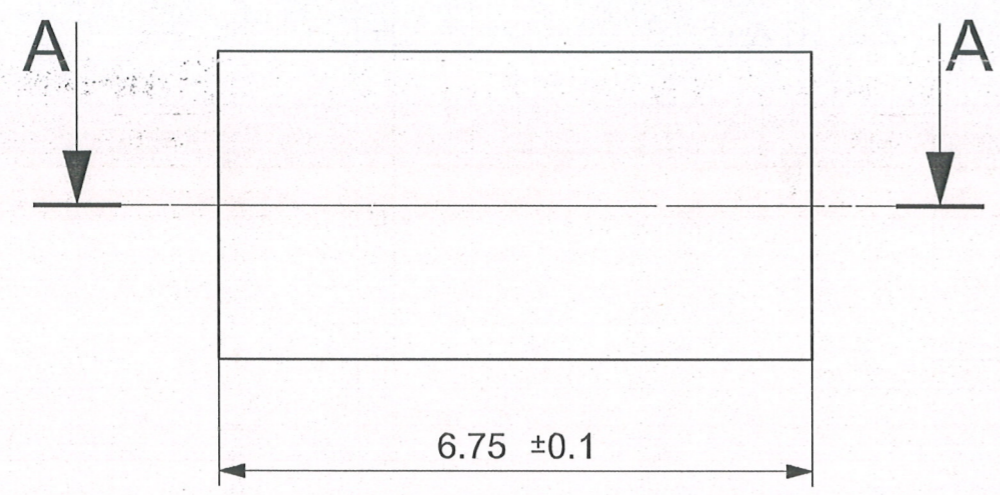

SECTION A-A

ISOMETRIC VIEW

MATERIAL:- STEEL BS970 Pt.1:1983 Gd.080M40 OR En-8

HEAT TREATMENT:- HARDENED & TEMPERED TO 250 - 300 H.V.

PROTECTIVE FINISH:-PHOSPHATED TO SPECN. J.S.S.-0465-01:1988 CLASS II (ACCELERATED) OIL FINISH.

DIMENSIONS ARE IN MM.

REVOLVER.32 (7.65 mm) SIDE SWING  BUSHING TRIGGER	DESIGNED BY	<i>A.S.RANA</i> A.S.RANA
	CHECKED BY	<i>JWM/DDO</i> JWM/DDO
	APPROVED BY	<i>WM/DDO</i> WM/DDO
	DATE	25.06.2019
SCALE 12 : 1	DRAWING NO.	
	RV-07/7 SW	
SMALL ARMS FACTORY KANPUR		SHEET 1 OF 1
		A3