

S.No	BEARING DESIGNATION	Ød	ØD	B	r	USED ON	CLASS OF ACCURACY ETY-500	EQUIVALENT BEARING (FOR REFERENCE)
1	104	20	42	12	1.0	172-46-002CD-1 188-45-001 CD-3	0	KNK 6004
2	106	30	55	13	1.5	188-45-001 CD-3	0	SKF/6006 HMT/6006, FAG/6006 & NBC/6006, KNK 6006
3	111 П	55	90	18	2.0	188-45-001 CD-3	0	SKF/6011 M/PG & HMT/6011 FY/PG, KNK 6011 M/PG
4	113 П	65	100	18	2.0	188-45-001 CD-3	0	SKF/6013 M/PG & HMT/6013 FY/PG, KNK 6013 M/PG
5	128	140	210	33	3.0	188-45-001 CD-3	0	SKF/6028 HMT/6028
6	202	15	35	11	1.0	172-46-002 CD-1	0	SKF/6202 HMT/6202, FAG/6202 & NBC/115 KNK 6202
7	205	25	52	15	1.5	188-45-001 CD-3 172-47-015CD	0	SKF/6205 HMT/6205 & FAG/6205
8	206	30	62	16	1.5	188-45-001 CD-3	0	SKF/6206 HMT/6206, FAG/6206
9	210	50	90	20	2.0	188-45-001 CD-3	0	SKF/6210 HMT/6210, FAG/6210 & NBC/150 & SBL 210K
10	211	55	100	21	2.5	188-45-001 CD-3	0	SKF/6211 HMT/6211, FAG/6211 & NBC/155 & SBL 211K
11	212	60	110	22	2.5	188-45-001 CD-3	0	SKF/6212 HMT/6212, FAG/6212 NBC/160 & SBL 212K, KNK 6212
12	309 П	45	100	25	2.5	188-45-001 CD-3	0	SKF/6309 M/PG HMT/6309 M/FY, KNK 6309
13	7000107	35	62	9	0.5	188-45-001 CD-3	0	SKF/16007 HMT/16007, FAG/16007

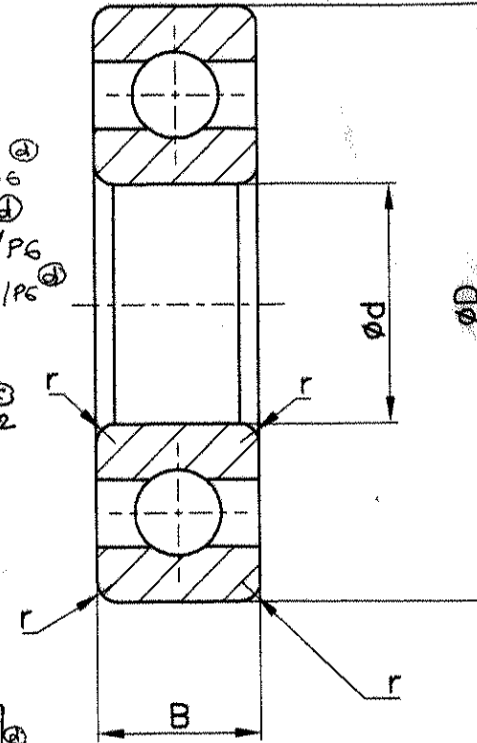

CHEMICAL COMPOSITION (%)		
ELEMENT	ISX15 GOST 801-78	SAE 52100
C	0.95-1.05	0.95-1.10
Si	0.17-0.37	0.20-0.35
Mn	0.20-0.40	0.25-0.45
Cr	1.30-1.65	1.30-1.60
S	0.02 Max.	0.025 Max.
P	0.027 Max.	0.025 Max.
Ni	0.30 Max.	--
Cu	0.25 Max.	--
Ni+Cu	0.50 Max.	--



@ EQUIVALENT BEARINGS ADDED:
AS PER CQA (HV), LETTER NO. 98704/04/ID-COORD/ALT. COM.
DATED: 05/03/2007.

@ Authority: CQA (HV) AVADI letter no. 98704/00/ID COORD/ALT. COM
dt. 14.10.08

ALTERNATE MATERIAL: SAE 52100 TO AISI

AUTHORITY: CQA (HV), AVADI, LETTER NO. 98704/04/ID-CO ORD/ALT COM
DATED 03/05/2005

@ AUTHORITY: CQA (HV) AVADI LETTER NO. 98704/04/ID COORD/ALT. COM
dt. 28.08.2007 HRC:61-65

@ Authority: CQA (HV) AVADI LETTER NO. 98704/04/ID COORD/ALT COM DT. 23.05.08

IT - INDICATES CAGE IS MADE OF BRASS.

NOTES:-

1. BEARING SHOULD BE FREE FROM CRACKS, CORROSION AND ALSO GRINDING BURRS IN THE SHAPE OF SPOTS OF SECONDARY HARDENING AND SECONDARY TEMPERING.
2. BEARING PARTS SHOULD BE DEMAGNETISED.
3. SURFACE QUALITY IS INSPECTED BY NON-DESTRUCTIVE METHODS SURFACE QUALITY MAY BE CHECKED, WITHOUT THE USE OF MAGNIFYING DEVICES.
4. ABSENCE OF SHRINK HOLES MAY BE CHECKED ON DISCS. CUT FROM TWO ENDS OF A ROD OR BUNDLE, BY MAGNETIC METHOD.
5. PILOT SAMPLE SHOULD BE APPROVED BY A.S.H.P BEFORE BULK SUPPLY.

#) THIS SKETCH ALONG WITH ALL DETAILS IS AN ABSTRACT BASED ON GOST-8338-75

SINGLE ROW RADIAL BALL BEARING		ISX15	GOST 801-78			
संख्या NO OFF	विवरण DESCRIPTION	पुर्जा क्र. PART NO.	पदार्थ MATERIAL	मानक STANDARD	परिमाण DIMENSIONS	अध्यक्षित REMARKS
	सामान्य सहिष्णुता GENERAL TOLERANCE	①	Equivalent added	②	EQUIVALENT BEARING ADDED.	
	रेखिक परिमाण LINEAR DIMENSION	②	DRG UP TO DATED ON. 7. 6. 11	③	Equivalent Bearing FAG 6202 & NBC 115 deleted for bearing designation 128 vide CQA (HV) letter no. 98704/04/ID-COORD/ALT. COM dt. 20.06.2007	
0-6	±0.1					
6-30	±0.2					
30-120	±0.3					
120-315	±0.5					
315-1000	±0.8					
1000-2000	±1.2					
	कोणिक परिमाण ANGULAR DIMENSION	संख्या NO. OFF	संबंधित पुर्जा का आरेखण क्र. DRG. NO. OF ASSOCIATED PART	सूचक INDEX	संशोधन ALTERATION	2006 दिनांक DATE
1-10	±1'					
10-50	±30'					
50-100	±20'					
>100	±10'					
	मापक 'म्यू एम' में VALUE IN 'um'					
-	>25					
∇	8-25					
∇∇	1.6-8					
∇∇∇	0.025-1.6					
∇∇∇∇	<0.025					
SINGLE ROW RADIAL BALL BEARING TRANSMISSION GEAR UNIT CODE - 45 / T-72 & T-90				मापमान SCALE		आरेखित DRAWN
				NTS		10.02.06 DHR
				जाँचा CHECKED		15.2.06
				अनुमोदित APPROVED		15.02 d
				द्वारा बदला REPLACED BY		
				हेतु बदला REPLACED FOR		
				कार्यालय OFFICE		
				D.O.		
				मशीनी औजार आदिरूप फैक्टरी, अम्बरनाथ MACHINE TOOL PROTOTYPE FACTORY, AMBERNATH		
				मूलमाप व अन्वयोजन NOMINAL SIZE & FIT		विचलन DEVIATION
				आरेखण क्र. DRAWING NO.		MPF/IGB/8338

इन आरेखणों तथा इसके साथ की सम्पूर्ण सामग्री का स्वत्वाधिकार भारत सरकार रक्षा मंत्रालय की भारतीय आयुध निर्माणियों के पास है। भारतीय आयुध निर्माणियों के महानिदेशक की लिखित अनुमति के बिना इनकी नकल या किसी भी रूप में इनके उद्धरण या इनमें समाहित सूचना किसी अनधिकृत व्यक्ति को उपलब्ध नहीं कराई जानी चाहिए।

THE COPYRIGHT OF THESE DRAWINGS AND ALL ATTACHMENTS THERE TO BELONGS TO THE INDIAN ORDNANCE FACTORIES, MINISTRY OF DEFENCE, GOVT. OF INDIA THEY SHOULD NOT BE COPIED, REPRODUCED IN ANY WAY OR THE INFORMATION CONTAINED THEREIN MADE AVAILABLE TO UNAUTHORISED PERSONS WITHOUT THE WRITTEN PERMISSION OF THE DIRECTOR OF ORDNANCE FACTORIES.