

PROVISIONAL

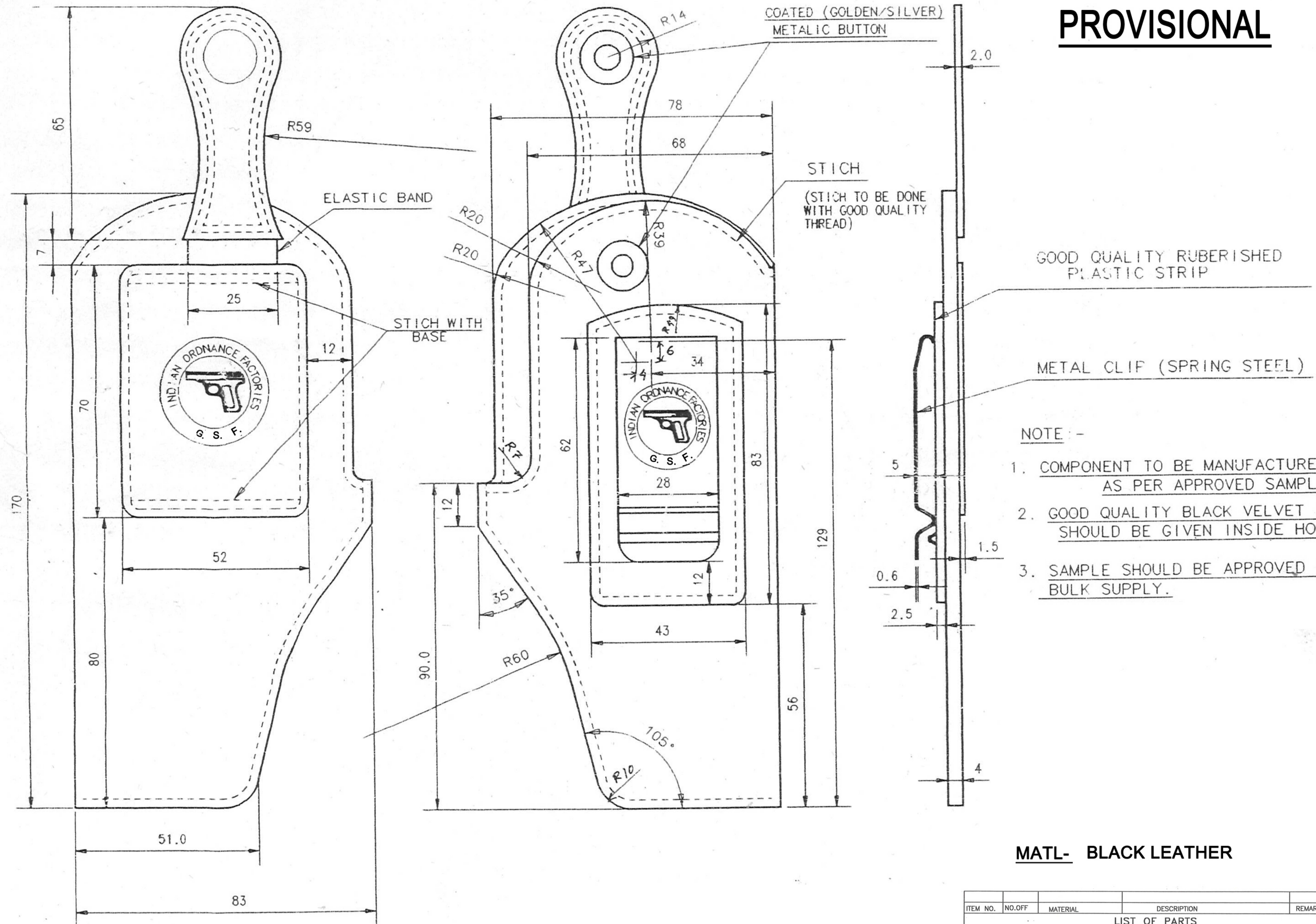

- NOTE -**
1. COMPONENT TO BE MANUFACTURED AS PER APPROVED SAMPLE
 2. GOOD QUALITY BLACK VELVET LINER SHOULD BE GIVEN INSIDE HOLSTER
 3. SAMPLE SHOULD BE APPROVED BEFORE BULK SUPPLY.

MATL- BLACK LEATHER

Prateek
05/08/18
APPROVED BY : AWM/ PISTOL

ITEM NO.	NO.OFF	MATERIAL	DESCRIPTION	REMARKS
LIST OF PARTS				
		SCHEDULE NO :	COMPT- LO.F PISTOL 7.65 MM (0.32")	STORE DRG. No.
		SCALE=	PROJECTION : THIRD ANGLE	
		DRAWN BY :	<i>S.B. S</i>	HOLSTAR
		TRACED BY :		FOR MODIFIED 0.32" PISTOL
		CHECKED BY :		DRG. NO. :- CTM-0133
		APPROVED BY :	<i>S.B. S</i>	
DT.&SG.	DESCRIPTION	CONCURRED BY:	M/C :	NO. OF SHTS. : 1
AMENDMENTS	DATE:	SIGN:	G. & S. FY. COSSIPORE	SHIT. NO. : 1.