

JSS 0 V VV S SS IC
 000 030 00 20 10 1012
 DRG No. 210101201012

GENERAL TOL. : FINE / MEDIUM / COARSE
 CLASS TO IS: 2102

DRG. CONVENTIONS CONFIRM TO INDIAN STANDARDS
 DIMENSIONS ARE IN mm UNLESS OTHERWISE STATED.

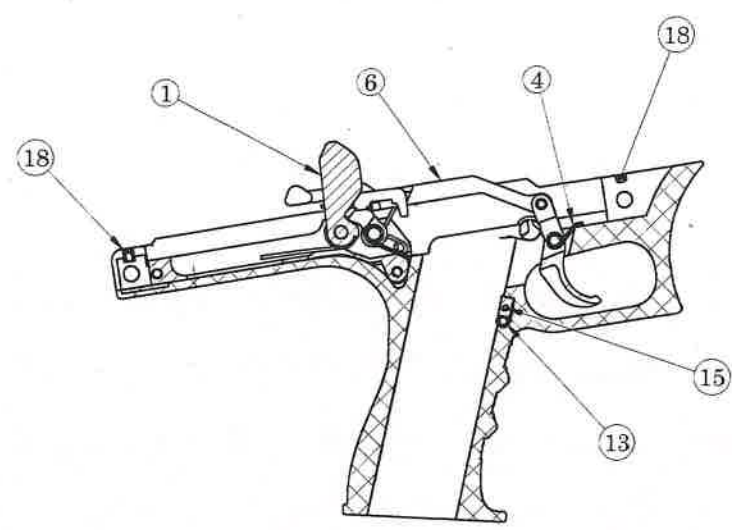

SECTION A-A

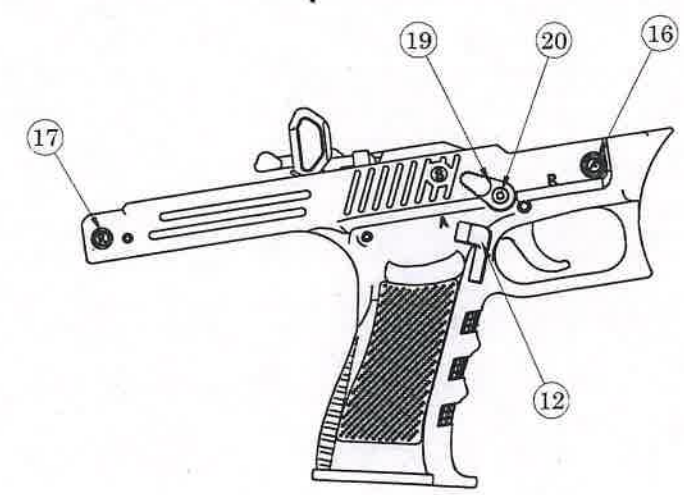

SECTION B-B

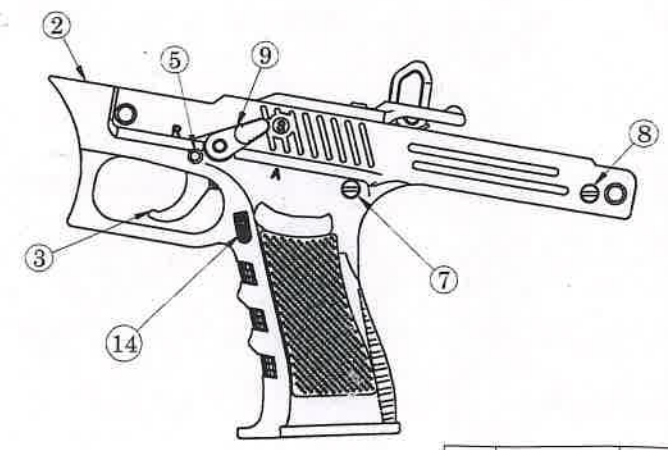
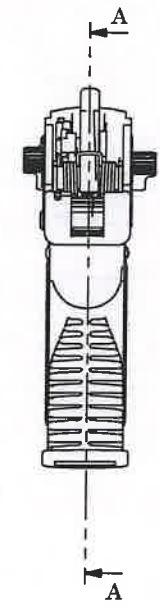

CONTROLLED COPY No.: 01

ITEM NO.	PART NUMBER	DESCRIPTION	QTY.
1	TRIGGER MECHANISM ASSEMBLY	2101 01 02 03 10 000 00DA	1
2	PISTOL GRIP AND LOWER HOUSING	2101 01 02 00 03 001 00DA	1
3	TRIGGER FRONT	2101 01 02 00 03 002 00DA	1
4	SPRING FRONT TRIGGER	2101 01 02 00 03 003 00DA	1
5	PIN TRIGGER FRONT	2101 01 02 00 03 004 00DA	1
6	LINK	2101 01 02 00 03 005 00DA	1
7	SCREW FRONT TRIGGER HOUSING	2101 01 02 00 03 006 00DA	1
8	SCREW REAR TRIGGER HOUSING	2101 01 02 00 03 007 00DA	1
9	STUD CHANGE LEVER	2101 01 02 00 03 008 00DA	1
10	PLUNGER SAFETY CATCH	2101 01 02 00 03 009 00DA	1
11	SPRING PLUNGER SAFETY CATCH	2101 01 02 00 03 010 00DA	1
12	CATCH MAGAZINE	2101 01 02 00 03 011 00DA	1
13	SPRING CATCH MAGAZINE	2101 01 02 00 03 012 00DA	1
14	BUTTON CATCH MAGAZINE	2101 01 02 00 03 013 00DA	1
15	SCREW CATCH MAGAZINE	2101 01 02 00 03 014 00DA	1
16	CAPTIVE PIN FRONT	2101 01 02 00 03 015 00DA	1
17	CAPTIVE PIN REAR	2101 01 02 00 03 016 00DA	1
18	WIRE SPRING CAPTIVE PIN NEW	2101 01 02 00 03 017 00DA	2
19	LEVER CHANGE	2101 01 02 00 03 018 00DA	1
20	SCREW LEVER STUD CHANGE	2101 01 02 00 03 019 00DA	1

NOTE:
 ASSEMBLY TO BE CARRIED OUT AS PER ASSEMBLY PROCEDURE
 DOC. No. ARDE/9mm MP/ASSY/2022/01

Sr. No.	DATE	AUTHORITY	BRIEF RECORD	ZONE	CD	GO
DRN: AKASH	SIGN:	DATE: 24/08/2022	CHECKED	MATERIAL:		
APPD.	DATE: 24/08/2022	FOR DIRECTOR	PROTECTIVE FINISH:			
SEALED DATE:	SHEET SIZE: A2	EST. MASS	TITLE:			
SCALE: 1:2	DESIGN AUTHORITY	ARDE	PUNE 411021	LOWER HOUSING ASSEMBLY		
DRG No. 21010101012	IC	SS	S	AA	A	C
9 mm	PART No.	DS CAT No.	AHSP			