

DIMENSIONS ARE IN mm.

UNTOLERATED DIMNS. AS PER IS : 2102 (MED)

SHARP CORNERS SHOULD BE BLUNT TO R 0.5

PROTECTIVE FINISH : PHOSPATED TO SPECIFICATION. JSS : 0465-01-1988  
CLASS-I (ACCELERATED) OIL FINISH.

UN CONTROLLED COPY  
 CERTIFIED CORRECT COPY OF APPROVED  
 DRAWINGS AT THIS DATE.....  
 25.05.2021  
 DESIGN & DRAWING OFFICE,  
 ORDNANCE FACTORY, TIRUCHIRAPPALI - 620 016.

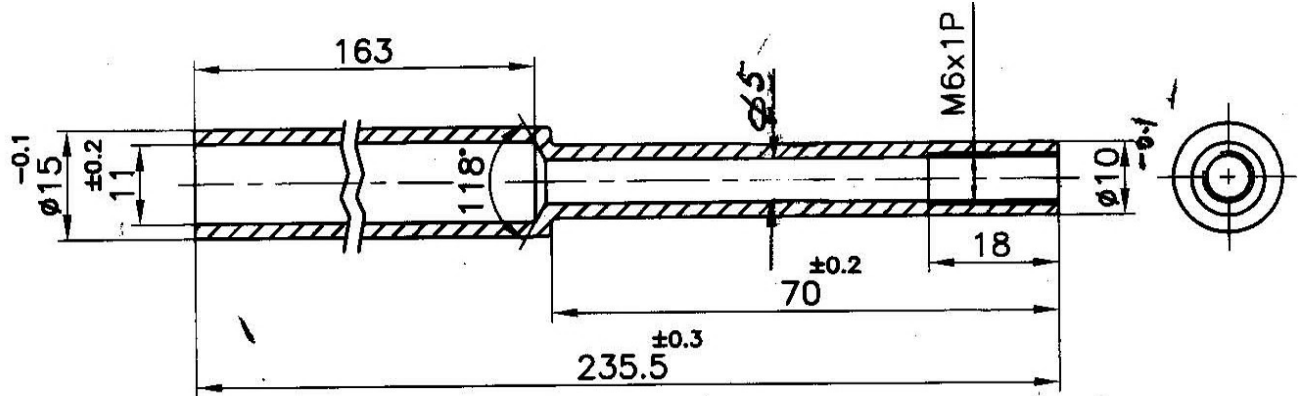

MATERIAL:- IS: 1875 - 1992, CLASS-4, DES. 45 C8

(OR) BS:970 PT1, 1983, GRADE - 080M40.

ALTERNATE MATERIAL: En8

HARDNESS: 325-375 HV

PART NO.	DESCRIPTIONS	NO OFF	MATERIAL	TREATMENT	REMARKS
	SIGNATURE & DATE.	SUB: <u>ROD HANDLE</u>			SCALE N.T.S
	TRACED	FOR: <u>HANDLE RELEASE SUB ASSY</u>			STORE DRG.NO.
	DRAWN <i>[Signature]</i>	OF: <u>38 mm MSL</u>			OPERATION NO.
	CHECKED <i>[Signature]</i>	DES.REF.NO.			
	HOS/D&DO <i>[Signature]</i>	DRG. No.: <u>33P 2021</u>			
	NSBL OFFICER FOR MSL	 ORDNANCE FACTORY TIRUCHIRAPPALI-16.			SHEETS: 1
	OFFICER/D&DO <i>[Signature]</i>				SHEET No.: 1
AMENDMENTS	SIG. & DATE	APPROVED ON. <u>22/12/2014</u>			