

8 7 6 5 4 3 2 1

DRAWING CONVENTIONS CONFORM TO IS: 696.

SURFACES FINISH :- AS PER IS: 3073-67,
WHERE NOT SPECIFIED SHOULD BE ∇

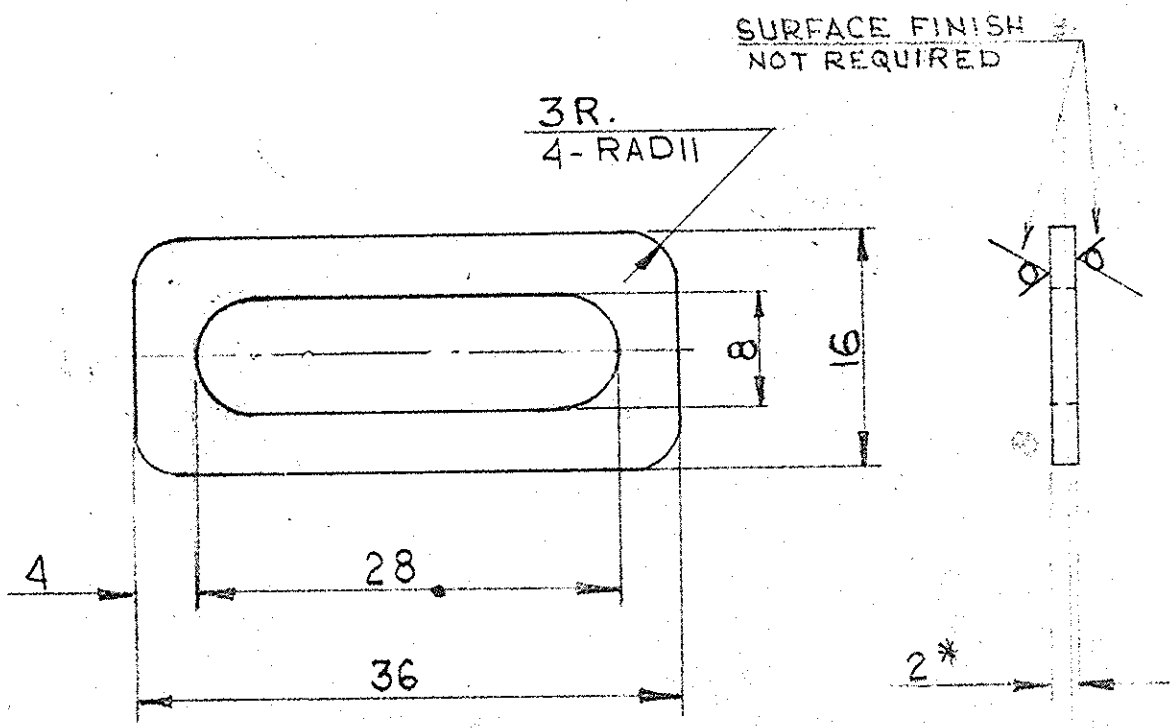

1. * DIMENSIONS FOR REFERENCE.
2. SHARP EDGES TO BE BLUNTED R 0.2 mm.
3. COATING & CHEMICAL PHOSPHATING ACCELERATED, OIL FINISH.
4. THE REST OF THE REQUIREMENTS ARE AS PER 6011 SPECIFICATION.

MATERIAL:- SHEET 5-09-0-2 GOST 19903-74
4-III-30 GOST 16523-70

MATL. FOR INDIA:-
30 HS BS 1449 PT.1:1983 SEC.4

PROTECTIVE FINISH FOR INDIA:-
PHOSPHATE TO SPECN. JSS: 0465:01-1988
CLASS II OIL FINISH

A-9
21

CERTIFIED COPY OF THE STORE
DRG CAUCE DRG/SCHEDULE/
/NOTE SHEET/SPECIFICATION.
COA (SA) ICHAPUR
DATE: 21/9/98

					DATE	NAME	ASSEMBLY	6101400100-505	COA(SA) ICHAPUR
					DGN.				
					DRN.	SKL		MATERIAL:- AS STATED	
					CHD.	Q.2.2.1		DIMENSIONS ARE IN MILLIMETRES	
					TRD.				APPROVED
					COMP.				
						DT. 24.9.90	IC: D.O.		DT. 24.9.90 FOR COA(SA)
						SCALE:- 2:1			DESIGNER'S REF
						SEALED:- PROV.			61014 100-14
						DCC(I) 20963-SA			DS.CAT.NO.
						DT. 23.10.90			

20984-6-11-90
SA
20963-23-10-90
SA

MATL. & PROT. FINISH FOR INDIA ADDED
DRG. SEALED PROVISIONALLY
LT. COL

BUCKLE