

DETAIL K

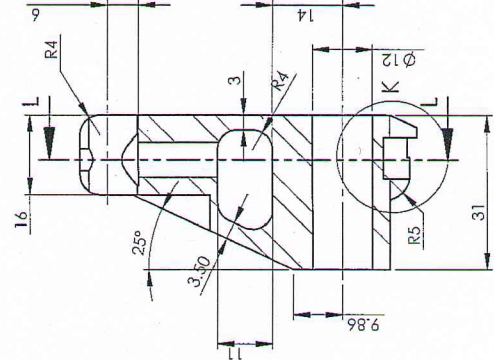

SECTION H-H

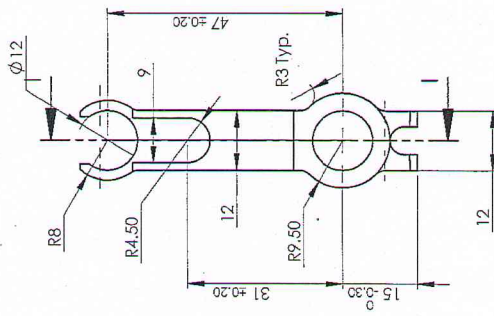
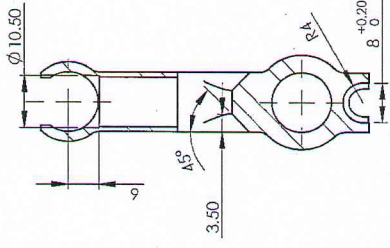

SECTION L-L

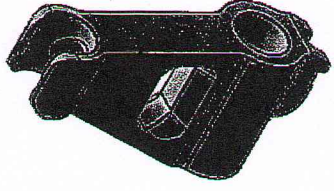

UN CONTROLLED COPY
 CERTIFIED CORRECT COPY OF APPROVED
 DRAWINGS AT THIS DATE. 21.10.12
 DESIGN & DRAWING OFFICE,
 ORDNANCE FACTORY, TIRUCHIRAPPALLI-620 016.

Material for Casting:-

BS:3146 PART-1, 1974 Class:5, Grade:A
 Non Stressed Component
 Radiographic Test as per ASTM-E-192
 Hardness : 230 BHN max

Acceptance Standard:-

Gas hole & Foreign Material: Level-3
 Shrinkage (All Types) : Level 3

Note:- for Casting

Tolerance as per IS:1166 Class-I
 Flatness Tolerance : ±0.1 / 25.4mm
 Casting Radius 0.5 mm

| | | | | | |
|------------------------|--------------------|----------------------------------|--|--------------|--|
| SIGNATURE & DATE | | SUB: IC-Front Sight Block | | SCALE | |
| TRACED | | FOR: Front Sight Block | | NTS | |
| DRAWN | <i>V. Palani</i> | OF: TRICHY ASSAULT RIFLE | | QPC | |
| CHECKED | <i>V. Palani</i> | DES. REF. NO. K1207 | | 1 | |
| OIC/D&DO | <i>A. J. S. S.</i> | DRG. No.: IC-K-1207 | | Weight(g) | |
| OFFICER/PRODN | | | | 85.50 g | |
| DWG/OFFICER/D&DO | <i>G. K.</i> | | | SHEETS: 1 | |
| APPROVED ON 01/12/2018 | | | | SHEET No.: 1 | |
| AMENDMENTS & DATE | | ORDNANCE FACTORY | | | |
| | | TIRUCHIRAPPALLI-16. | | | |