

**RESTRICTED
(DRAFT/PROVISIONAL)
QUALITY ASSURANCE PLAN**

FOR

(LEVER (INVESTMENT CASTING))

DRG.NO. 172.28.135-3/IC

(LF NO: 3806211141)

No.HVF/T-90/QAP/28/LEVER (INVESTMENT CASTING) /241279-00

ISSUE No:00

DATE: AUG-2021

QUALITY ASSURANCE (RIG-SUB ASSEMBLY)

HEAVY VEHICLES FACTORY

AVADI CHENNAI – 600 054

QUALITY ASSURANCE PLAN (QAP)

FOR

LEVER (INVESTMENT CASTING)

172.28.135-3/IC

PREPARED BY



(V. RAJA)

JWM/QA (RIG-SA/ST&CT)

REVIEWED BY

(C. NANDAKUMAR)
JWM/QA (RIG-SA)

APPROVED / REVIEWED BY

(SUBHAM BIJLWAN)
AWM/QA-RIG-(SA)

ISSUED BY

QUALITY ASSURANCE (RIG- SUB ASSEMBLY)
HEAVY VEHICLES FACTORY
AVADI CHENNAI – 600 054

Sl. no	CONTENTS	PAGE .No.
1.	IMPORTANT NOTES	4
2.	INTRODUCTION	4
3.	AIM	4
4.	SCOPE	5
5.	DOCUMENTS	5
6.	ITEM USED ON	6
7.	LIST OF DRAWINGS	6
8.	BILL OF MATERIAL	6
9.	CONDITIONS OF USE/ STORAGE INSTRUCTIONS	6
10.	SAMPLING PLAN	6
11.	VISUAL INSPECTION	7
12.	DIMENSIONAL CHECKS	8
13.	MATERIAL CHECKS	9
14.	ACCEPTANCE / PERFORMANCE TESTS	10
15.	FITMENT AND PERFORMANCE TEST	10
16.	INTERCHANGEABILITY	11
17.	CALIBRATION CHECKS	11
18.	MARKING/IDENTIFICATION	11
19.	PRESERVATION CHECK	11
20.	PACKING CHECK	11
21.	DOCUMENTATION	12
22.	REFERENCE	12
23.	ANNEXURE - A	13
24.	FIGURE OF THE SAMPLE	14
25.	APPENDIX - A	15

1. IMPORTANT NOTE

Note-1

This is only a provisional and will be amended from time to time according to the requirement. No addition, deletion and reproduction will be done without permission of The Sr. General Manager, Heavy Vehicles Factory, Avadi, Chennai – 54.

Note –2

Any instruction contained in this does not prejudice the terms and conditions of the contract what so ever. In case of any contradiction between the contents of this QAP and the clause in the contract, the latter will prevail.

Note-3

The stores should be manufactured strictly only as per the drawings supplied by the Inspection Authority and not as per the samples, if any received by the manufacturer for guidance purpose.

Note-4

Any amendment issued by the Inspection Authority shall be incorporated in the QAP and the records for the amendments carried out should be maintained as per the Performa at Appendix-“A”.

Note-5

In case of any contradiction between the contents of this QAP and drawings issued along with the contract, the latter will prevail.

2. INTRODUCTION

1. This quality plan lays down the inspection and testing procedure to be carried out on the component **LEVER (INVESTMENT CASTING) TO DRG NO. 172.28.135-3/IC** being procured indigenously. This is prepared, based on the acceptance standards and inspection parameters laid down in collaborators documents and on the inspection test standards followed in respect of similar indigenous items.
2. This QAP is the property of Government of India and is liable for amendments as and when required. The Sr. General Manager, Heavy Vehicles Factory, Avadi, Chennai – 600 054, is the inspecting Authority for this assembly. Any query / clarification on the content of this QAP shall be referred to this Factory. Any departure from these instructions is allowed only after written approval from the above authority. Notwithstanding the tests indicated in this QAP, the inspecting Officer has the right to carry out any test to check conformance to the paper particulars quoted in the Supply Order, which he may consider necessary to satisfy himself about the stores which he has to accept.

3. AIM

The QAP is aimed at standardizing the Inspection procedure and acceptance norm for **LEVER (INVESTMENT CASTING) TO DRG NO. 172.28.135-3/IC**.

It also aims at giving adequate information to the manufacturer on the quality requirements so that the required quality control methods are established.

This is also meant to guide authorized Inspection Officer in his routine inspection and to set out main points to which his attention must be drawn to ensure that the accepted stores meet the stipulated standards.

4. SCOPE:

This QAP outlines in general terms, the checks and methods to be used during inspection of **LEVER (INVESTMENT CASTING) TO DRG NO. 172.28.135-3/IC** including the technical requirements of the drawings. The recommended Quality Plan stipulated herein is mandatory and should be strictly adhered to.

For inspection purpose, only the latest issue of this QAP will be made applicable and copies of this QAP can be obtained from the issuing authority i.e. The Sr. General Manager, Heavy Vehicles Factory, Avadi, and Chennai.

Note:

- i. Tender enquiry (TE) and supply order (S.O) will be issued with QAP stating that inspection will be done as per QAP.
- ii. In case of TE, It is responsibility of the vendor to obtain the copy of QAP and give the statement of compliance that vendor will abide by the QAP in case supply order is placed.
- iii. In case of S.O, it is the responsible of the vendor to obtained copy of QAP and give the statement of compliance that the vendor will follow QAP. However, GM/HVF reserves the right to revise/update the QAP from time to time.

5. DOCUMENTS:

- a) On placement of firm supply order, One set of relevant specification and technical instructions on the subject item can be obtained by the contractor from AHSP through DDO/HVF
- b) Any clarification required on these documents should be obtained from the Inspecting Authority i.e. The Sr. General Manager, Heavy Vehicles Factory, Avadi, Chennai – 600 054. Equivalentents to the collaborators specifications and standards will be decided only by the Inspecting Authority and should not be unilaterally decided. For any change in the specifications, standards or written approval, any alterations in specification can be affected and not otherwise.
- c) The process instruction sheets supplied by the collaborators are available with the Authority Holding Sealed Particulars, i.e. The Controllerate of Quality Assurance (Heavy Vehicles), Avadi, Chennai for the reference. The relevant process sheets may be studied at the premises of the AHSP after obtaining necessary permission.
- d) The supplier after scrutiny of the concerned process sheets and connected paper particulars should establish the necessary production and inspection facilities. Particularly the inspection test rigs, stands, fixtures, template, gauges etc should be provided as recommended in these process sheets. If process sheet / Process Book is not available the details particulars/parameters available in the drawings to be strictly adhered.

6. ITEM USED ON:

1. 172.28.135-3 - LEVER

7. LIST OF DRAWINGS:

Single (individual) item

SI. NO.	DRG. NO	NOMENCLATURE	REMARKS
1	172.28.135-3/IC	LEVER (INVESTMENT CASTING)	-

8. BILL OF MATERIALS:

Single (individual) items, details as below,

SI. NO	DRG. NO	NOMENCLATURE	MATERIAL SPECIFICATIONS	Qty
1	172.28.135-3/IC	LEVER (INVESTMENT CASTING)	STEEL 40XII GOST 977-88	1

Note: Vendor/Contractor may use approved alternate material as per drawing. Refer Para 13.

9. CONDITIONS OF USE/STORAGE INSTRUCTIONS

This assembly/item should be properly packed to protect from transit / handling damage and influence of atmospheric precipitations. In addition, the following parameters should be ensured:

- (a) The threaded parts if any should be covered with suitable plastic caps to prevent damages.
- (b) If the item consists of assemblies, each assembly should be packed separately.
- (c) The stores are to be suitably covered for preventing ingress of dust and Dirt/entry of sunlight / moisture.
- (d) The packaging slip shall contains
 - (i) Certificate of testing (NABL)
 - (ii) Guarantee/ Warranty Certificate
 - (iii) Service and maintenance instructions
 - (iv) Delivery Slip with Inspector's Acceptance Mark
- (e) The stores are not permitted to be stored together with oils. Petrol, acids, alkaline and other substances to avoid damage to the metal / rubber components.

10. SAMPLING PLAN:

Sl. No.	Sampling Plan	Pilot *	Bulk
(i)	Visual Inspection	100%	100%
(ii)	Dimensional Inspection	100%	General Inspection level III, single sampling, Normal Inspection, AQL 2.5 of IS 2500 (Part-I)-2000

(iii)	Material Inspection	1 No	1 No. for each batch of raw material or heat treatment lot as required by specifications.
(iv)	Acceptance test	100%	-----
(v)	Pressure testing	-----	-----
(vi)	Machining / Fitment/ Performance trial on higher assembly / Tank	02 Nos.	-----
(vii)	Interchangeability Test	---	-----
(viii)	Test stand/Jigs/ Fixtures/Gauges/M andrels/etc.	100 %	100 %
(ix)	Marking/Identificati on	100%	100%
(x)	Packing/ Preservation	100%	100%

Note:-

*This clause is applicable if mentioned in supply order or project sanction order.

A New (First time supplier of this item) supplier should obtain clearance from HVF for bulk production which will be issued only after inspection/evaluation of pilot samples by HVF.

During acceptance of castings, the following are to be checked as per Specification: (For details refer Specification 172 TY 10 & GOST 977-88).

- chemical composition of steel;
- mechanical properties of steel;
- external view (absence of defects) and quality welding of casting defects;
- dimensions;
- hardness;
- absence of internal defects;
- microstructure.

11. VISUAL INSPECTION [Sampling plan as per Para- 10 (i)]

The stores are to be visually examined on 100 % of pilot /bulk and same should be free from any defects and all the finishing requirements shall satisfy as indicated in technical conditions of the assembly / component drawing.

The components shall be checked for the following and should be free from the defects:

- Defects in construction
- Cracks/Flaws/blowholes/shrinkage/porosities
- Fitment of all components
- Presence of foreign particles

- Moisture and dust
- Corrosion of metal parts
- Mechanical imperfections & distortion
- Any form of deterioration of material and finishing.

Packing and preservation should be ensured as per drawings/relevant TY specification (To be ensured on receipt at consignee end).

12. DIMENSIONAL CHECK[Sampling plan as per Para- 10(ii)]

The dimensions of individual component, sub assembly and major assembly shall be checked and ensured as per respective drawing. Dimensional check should be carried out as per sampling plan. However, the inspecting authority/rep. may at his discretion, tighten the inspection level and acceptance quality level on the critical items and adopt check point during manufacture.

12.1 LEVER (INVESTMENT CASTING) TO DRG.NO: 172.28.135-3/IC

1. All dimensions shall be confirmed as per drawing/specification

Sl. No.	Drawing Dimensions
1.	15°
2.	66(±0.5) mm
3.	R20 mm
4.	R10 mm
5.	43(±1) mm
6.	R10 mm
7.	15°
8.	135 (-1) mm
9.	R5 mm
10.	Hardness testing place
11.	62(±1) mm
12.	5.5(±1) mm
13.	1.5 mm
14.	5(±1) mm
15.	15°
16.	2(±1) mm
17.	15°
18.	10°
19.	R20 mm

20.	R20 mm
21.	R10 mm
22.	4(\pm 1) mm
23.	R6 mm
24.	15°
25.	R4 mm
26.	15°
27.	R2 mm
28.	30°
29.	26 mm
30.	R8 mm
31.	Φ 7 mm
32.	1.5 mm
33.	R8 mm
34.	4(\pm 0.5) mm
35.	15(\pm 1) mm
36.	4(\pm 1) mm
37.	$\bar{\sigma} R5$
38.	9.5 (-0.5) mm
39.	Place for marking refer Drawing.
40.	Surface finish / Roughness should be confirmed as per drawing and specification.

3. For admissible alternate method for manufacture in dimensions/material if any, refer drawing/specification.

13) MATERIAL CHECKS [SAMPLING PLAN AS PARA – 10 (iii)]

Material specimen /test bars of the components shall be in conformity as per the material mentioned in the relevant documents/drawing. The material check will be carried out as per sampling plan. However, if the manufacturer proposes any alternative material at the stage of tender enquiry, the same has to be approved and a written concurrence should be obtained from AHSP through DDO/HVF, before usage of such materials.

For each heat code/batch the test bars/test samples as specified in GOST/specification is to be submitted for testing chemical, mechanical, physical properties and other parameters of the casting and also the test certificates for the same tested by the supplier is to be submitted.

13.1 LEVER (INVESTMENT CASTING) TO 172.28.135-3/IC.

a) The component should be manufactured from STEEL 40XЛ GOST 977-88.

b) Chemical properties: As per STEEL 40XЛ GOST 977-88.

Grade of steel	Carbon	Magnesium	Silicon	Phosphor	Sulphur	Chromium
				Not more than		
40XЛ	0.35 to 0.45	0.40 to 0.90	0.20 to 0.40	0.040	0.40	0.80 to 1.10

Note : For mass fraction of other elements refer 977-88

The castings should be subjected to heat treatment. The mode of heat treatment for obtaining the given mechanical properties or the removal of internal stresses should be set by the manufacturing plant.

c). After final heat treatment, the mechanical properties of steel should comply with standards specified in table below

For more refer GOST 977-88

For details of other parameter/properties refer Specification STEEL 40XЛ GOST 977-88.

14) PERFORMANCES/ACCEPTANCE TEST: LEVER (INVESTMENT CASTING) to Drg. No. 172.28.135-3/IC.

The technical requirements shall be confirmed for acceptance of the component as specified in Specification and Drawing.

1. Casting of 1st group, GOST 977-88.
2. Casting material is steel 40XЛ GOST 977-88.
3. Alternate material is Steel 40Л,45Л,50Л.
4. Requirements for casting are as per 172 TY 10 .
5. Difference in measurement 'a', 'δ' should not exceed 2mm.
6. The remains of gate on surface 5 should not exceed 3 mm in height.
7. Scale 1:1.

Note:

- a) The Casting Manufacturers are required to follow the instructions strictly so far as supply of castings.(Refer Specification 172 TY 10 & GOST 977-88.).

15) FITMENT / MACHINING AND PERFORMANCE TEST:

- a. Pilot samples should be checked for fitment/machining trials and Performance test to ascertain the efficacy of the system under different operating conditions by fitting in higher assembly and repeating it for functional checks, wherever required.
- b. The item should possess appropriate material for machining as indicated in the drawing and should be supplied in such a way that the components to suit in machine/fixtures/Jigs etc to carry out machining.
- c. The component should be free from any defects after machining in trial and the casting should be in line with the parameters as specified in the GOST and Specification.
- d. The casting shall be clean, free from porosity blowholes, hard spots, Cold shut, distortion, cracks and other harmful defects as per the specification.

- e. The casting shall be well dressed and fettled and shall be readily machinable.
- f. Casting shall be cleaned/shot blasted and preservation coating is to be done after heat treatment as called for in the specification.
- g. No weld/repair should be carried out without prior permission from HVF.
- h. Testing methods for acceptance of the casting refer Specification 172 TY 10& GOST 977-88.

16) INTERCHANGEABILITY:

The assemblies should be interchangeable component wise and assembly wise, except the Component are to be supplied as a set and to be assembled selectively as per sampling plan.

17) CALIBRATION CHECKS

(TEST STANDS/JIGS/FIXTURES/GAUGES/INSTRUMENTS):

The supplier / Contractor should have suitable Instruments, Test Stand, jigs, fixture, mandrels, templates and gauges to carry out quality checks, to ensure conformance of components/assembly as per drawing and Specification /T.R points.

The supplier/contractor should submit calibration reports/certificates for instruments/fixtures/gauges/mandrels etc., which are used during process of inspection activities.

18) MARKING/IDENTIFICATION

Marking of the items is to be carried out as called for in the relevant drawing, drawing/T.R points.

Inscription if any on the components is to be carried out as called for in the drawing/T.R points. Unless otherwise specified in the drawing/ specification, marking should not be carried out over the components.

For traceability, marking of part No., Manufacturer name, supply order No, Serial No/Qty, batch No. and manufacture date & year are to be carried out. Suitable method can be adopted, provided that the above parameters are legible and considering the parameters mentioned in the drawing and specification.

19) PRESERVATION CHECK

a) Preservative coatings are to be strictly adhered to as called for in the drawing. However, equivalent BIS Standards can also be followed, subject to the thickness of the coating/preservative is maintained as per the drawing/specification.

b) Other preservations as necessary to prevent damages due to moisture and dust during process, storage and transit are to be carried out. Conventional Methods can also be resorted to.

20) PACKING CHECK

Components / Assemblies are to be packed separately to avoid damages during transit / handling of the same. Part No. and No. of sets are to be marked on the packing.

Packing and preservation should be ensured as per drawings/relevant TY specification (To be ensured on receipt at consignee end).

Finished products shall be wrapped / packed using black and opaque polyethylene sheet or bags.

21) DOCUMENTATION

- i. Firm has to maintain all the documents as per QAP with respect to the SI.No.to have traceability.
- ii. Vendor has to submit Bill of materials, Material test reports, Class 'C' /Endurance test reports (wherever specified in drawing/TY specification/QAP) and Complete PIR (pre-inspection report)at the time of offering the item for inspection. HVF will commence inspection only after scrutiny of these documents.
- iii. The testing/inspection responsibility to test all the parameters as per QAP and drawing specifications as mentioned in Annexure -A (enclosed).
- iv. Pre inspection reports (PIR) of firm like, 1. Chemical analysis, 2.Mechanical properties, 3. Pre-forming process, 4. Coating certification (wherever applicable), 5. Calibration reports of instruments and 6. 100% Dimensional inspection reports. 7. Pressure test (leakage test) if applicable, 8. Hardness checks, 9. Certificates for Macro/micro structure (wherever applicable), 10. Fracture test (if applicable) and other relevant test reports for acceptance of the Casting, etc.,

22) REFERENCE:

- a. Drawing No: LEVER (INVESTMENT CASTING) TO 172.28.135-3/IC
- b. *Material* specification as per drawing: STEEL 40XЛ GOST 977-88.
- c. GOST 977-88.
- d. Specification 172 TY 10.
- e. Alternate Material STEEL 40Л, 45Л, 50Л

LEVER (INVESTMENT CASTING) TO DRG. NO:172.28.135-3/C

Annexure - "A"

SL. NO.	CATEGO RY	ASSEMBLY/SU B ASSEMBLY	TESTS/INSPECTION PA RAMETERS	STANDARDS TO BE REFERRED	ACCEPTANCE CRITERIA	INSPECTION RESPONSIBILITY			REMARKS	
						Firm	HVF	DGOA		
1	LEVER (INVESTMENT CASTING) TO DRG. NO:172.28.135-3/IC									
1		Pre inspection reports (PIR) of firm	Firm has to produce all the document as per Para 21 (iv)	As per the relevant drawing and QAP.	Confirm to drawing and QAP as per bill of material	P	V	R	100% by firm/vendor.	
2		Bill of material (BOM)	Firm has to prepare the BOM as per QAP	Refer QAP Para no: 8 or item list.	Confirm to QAP.	P	V	R	100% by firm/vendor.	
3		Material tests	Chemical composition & Mechanical / Physical Properties	As per GOST 977-88	All the values to confirm with QAP (Para no:13.1 (a),(b) & (c)	P	W/V	R	SP followed by HVF.	
4		Dimensional checks	As per drawing & specification	As per Para 12.1 of QAP	All the values to confirm with QAP	P	W/P	R	100% by firm/vendor, SP followed by HVF.	
5		Machining Trial	Suitability of component for machining	Refer QAP Para no.10 (vi) & Para 15	Confirm to QAP Para no.10 (vi) & Para 15	-	P	R	SP followed by HVF	
6		Marking / traceability	Firm has to make marking / traceability records.	Refer QAP Para no: 18	Confirm to QAP Para no:18	P	V	R	100% by firm/vendor, SP followed by HVF	
7		Preservation & packing	Firm has to make Preservation & packing records	Refer QAP Para no: 19 & 20	Confirm to QAP Para no: 19 & 20	P	V	R	100% by firm/vendor.	

Note:

- For conformity of the items (Chemical/Physical/Mechanical properties).
- One sample per heat / batch shall be tested under NABL Lab/Govt. Approved lab by firm. In case of non-compliance to standards entire lot shall be rejected or not to use in production further.
 - For cross conformation of material, manufacturer has to submit sufficient quantity (as specified in GOST/Specification/supply order) test sample pieces for the items used / test slab and button for rubber items / HVF will draw samples from supplied lot for Witnessing (W) at HVF premises. In case of non-compliance to standards entire lot will be rejected.

P- Perform W- Witness V-Verify R-Review SP-Sampling Plan

FIG: LEVER (INVESTMENT CASTING) TO DRG. NO 172.28.135-3/IC

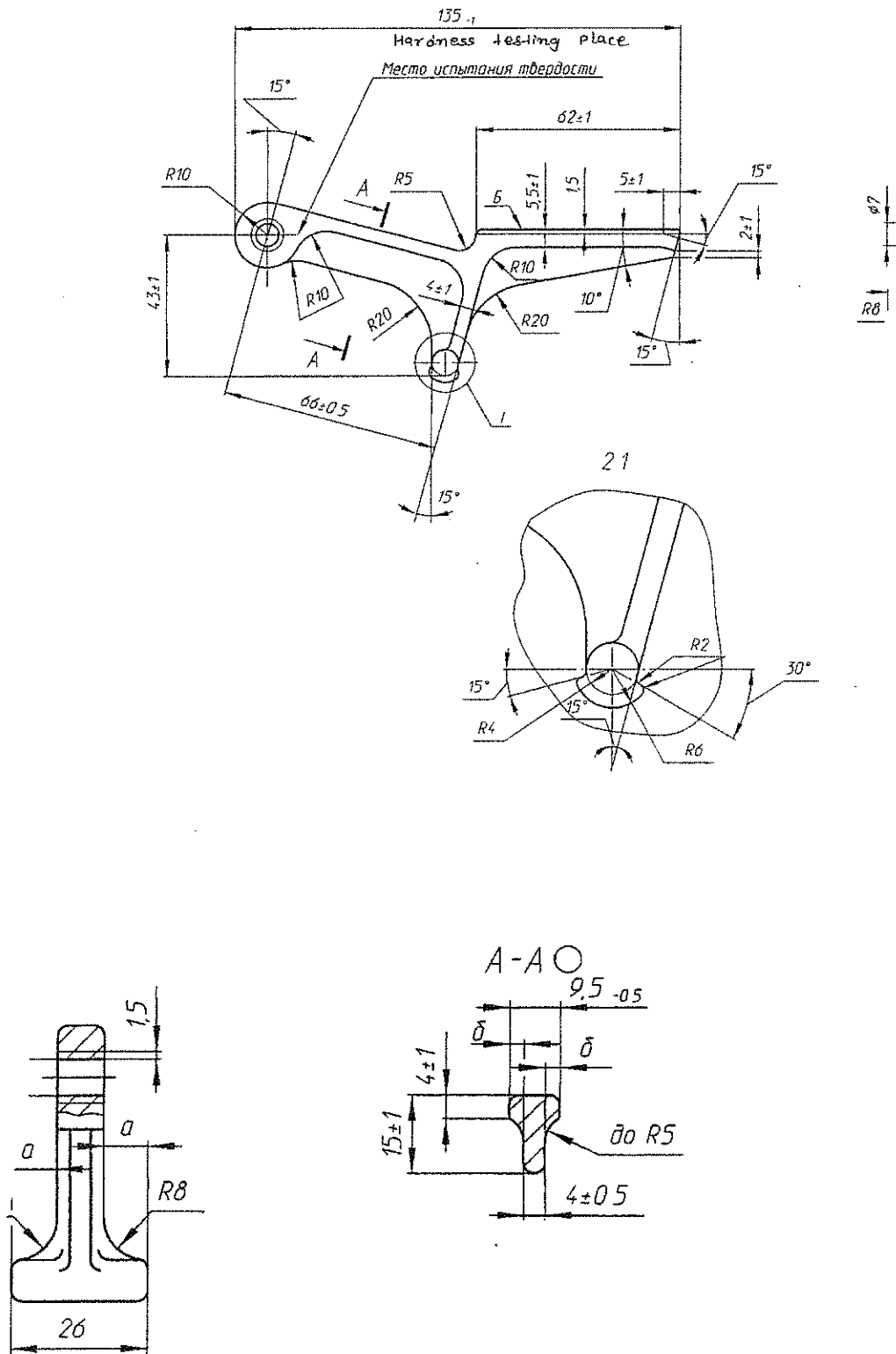

RECORD OF AMENDMENTS

Sl. No	Amendment No. & date	Amended by	Date of Insertion	Initial