

L/OUT No.

FACE MASK, GOGGLES N.V.P., 102A

DRG. No
IRDE-2016/16 SHT. 1

LOOP STRAP FASTENER

THIRD ANGLE PROJECTION

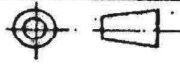

MCT-1856

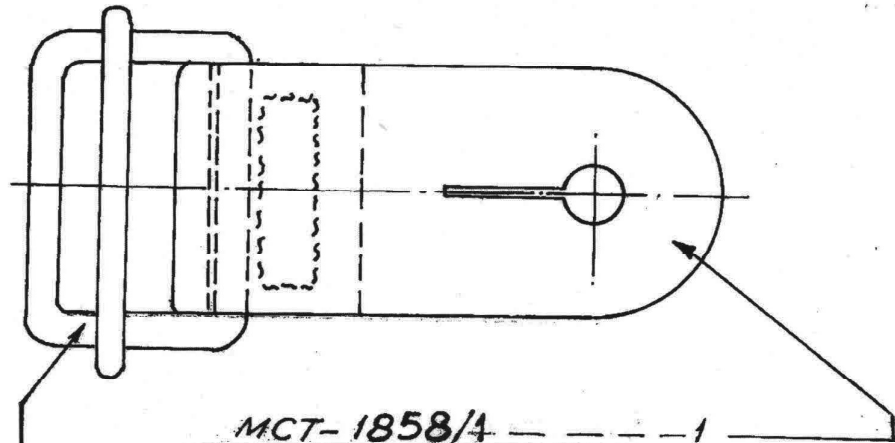

MCT-1858/4 — — — — 1
(TO BE STITCHED AS SHOWN)

MCT-1857 — — — — — 1

FOR TRADE MARK
Date of Issue 11/06/21
Rajm

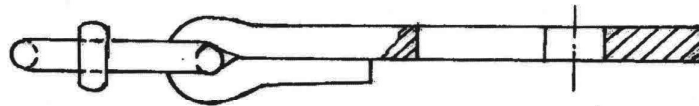

ORDNANCE FACTORY, DEHRADUN

DIMENSIONS ARE IN M/M.
IMPORTANT DIMENSIONS MARKED THUS ⊕
INFORMATION MARKED THUS † TO BE MARKED ON

	DR- <i>Amor</i>	DATE-30 ¹¹ / ₂₅	SCALE-2:1
	TR-	MATL.	TREAT.
	CH-	SEE DETAILS	SEE DETAILS
		SHEETS 1	SHT. No. 1
AMENDMENTS	APPROVED		DRAWING No.
OFD/DO/002	<i>[Signature]</i> JMM/D. O.	<i>N.K. Vij</i> AWM/TS	MCT-1856

ORDNANCE FACTORY, DEHRADUN

L/OUT No.

FACE MASK GOGGLES N.V.P. 102 A

LOOP STRAP FASTENER

DRG. No.
IRDE 2016/16 SHT-2

THIRD ANGLE PROJECTION

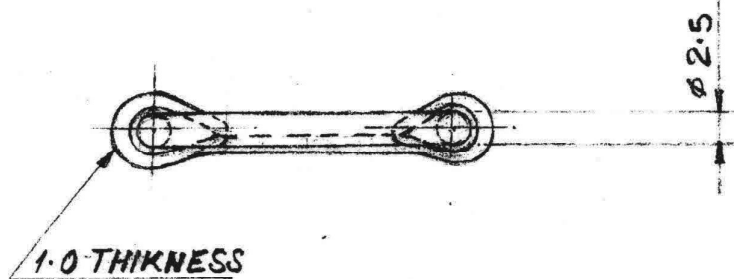
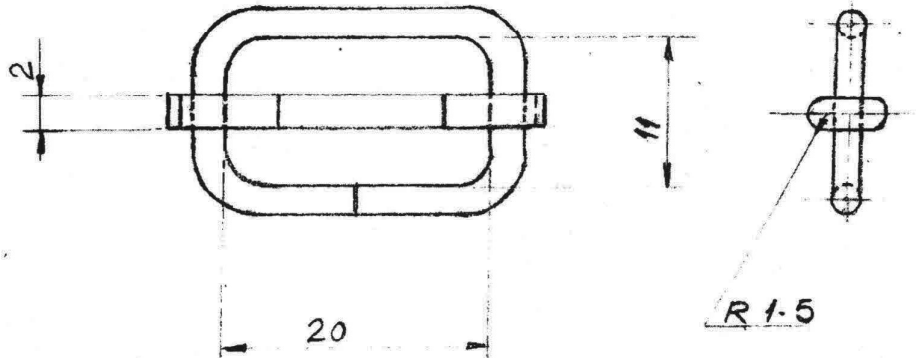
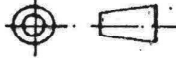

FOR TRADE COPY
Date of Issue 11/06/21
Rajiv

MATL. STEEL IS: 1570/C 10
FINISH: - PHOSPHATISED

DIMENSIONS ARE IN M/M.
IMPORTANT DIMENSIONS MARKED THUS ⊕
INFORMATION MARKED THUS † TO BE MARKED ON

	DR- <i>of hgt</i>	DATE-4 ¹² / ₂₀₀₀	SCALE-2:1
	TR-	MATL. AS ABOVE	TREAT. AS ABOVE
	CH-	SHEETS 1	SHT. No. 1
AMENDMENTS	APPROVED.	DRAWING No.	
OFD/DO/002	<i>[Signature]</i> ADM/TS	MCT-1857	

L/OUT No.

FACE MASK, GOGGLES N.V.P. 102 A.

DRG. NO

IRDE 2016/15

(SMT-3)

LOOP, STRAP FASTENER (LEATHER PIECE)

THIRD ANGLE PROJECTION

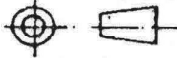

R 10.

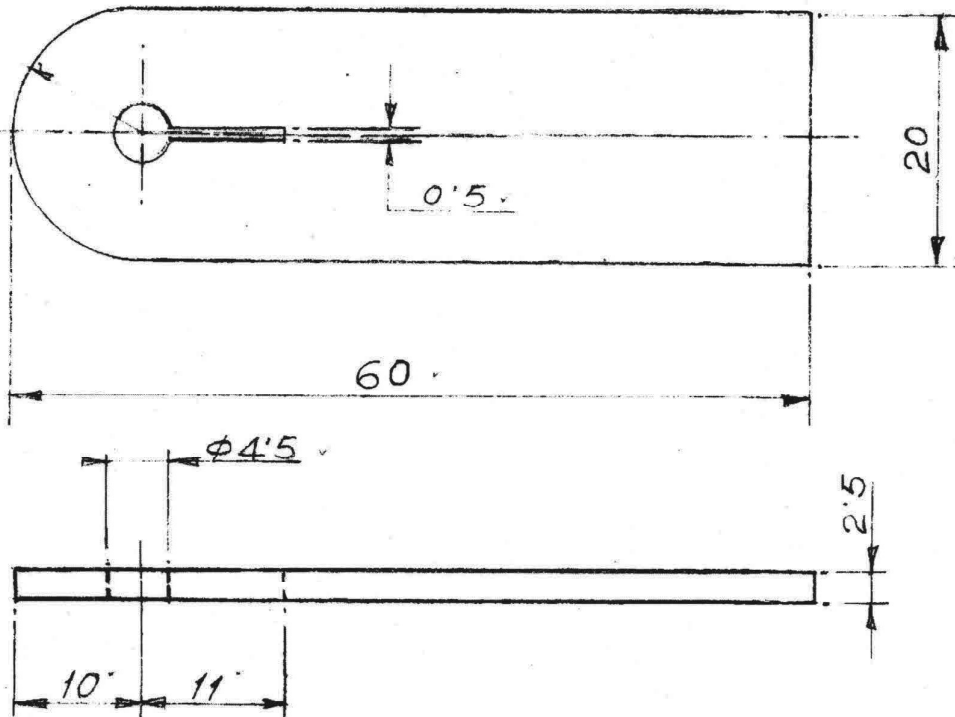

Date of Issue 11/04/2016

MATL. :-

LEATHER BUFFALO TANNED
2.5 mm. IS: 580-1973 II REVISION
BROWN COLOUR.

FINISH :-

ANTI-FUNGUS TREATMENT.

DIMENSIONS ARE IN M/M.
IMPORTANT DIMENSIONS MARKED THUS ⊙
INFORMATION MARKED THUS † TO BE MARKED ON

		DATE-30/11/2015	SCALE-2:1
DR- <i>[Signature]</i>		MATL.	TREAT.
TR-		AS ABOVE	-
CH- <i>[Signature]</i>		SHEETS 1	SHT. No. 1
(a) D.A. No. 10/2015 DT. 27.1.2015	APPROVED		DRAWING No.
AMENDMENTS	<i>[Signature]</i>	N.K. Vijaya	MCT-1858/A
OFD/DO/002	JMM/O. C.	AWM/TS	

ORDNANCE FACTORY, DEHRADUN

ORDNANCE FACTORY, DEHRADUN

L/OUT No.

**FACE MASK, GOGGLES NIGHT VISION PASSIVE, 102A
BUCKLE, SELF LOCKING**

DRG. No :- IRDE-2016/17

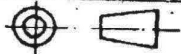
THIRD ANGLE PROJECTION 

MCT-1877

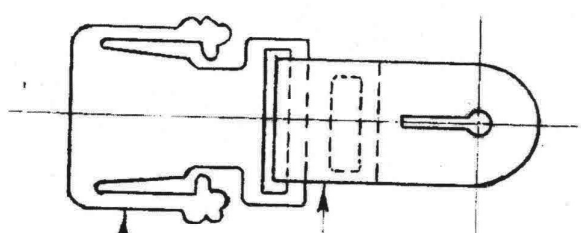

MCT-1858/1
(TO BE STITCHED AS SHOWN)

SELF LOCKING BUCKLE, 25 mm.
FEMALE PART, BLACK

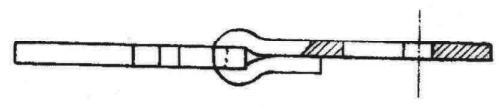

FOR TRADE USE
Date of Issue - 11/06/21
Rajiv

DIMENSIONS ARE IN M/M.
IMPORTANT DIMENSIONS MARKED THUS ⊙
INFORMATION MARKED THUS † TO BE MARKED ON

	DR- <i>Rakesh</i>	DATE-	SCALE- 1:1
	TR-	MATL.	TREAT.
	CH-	-	-
		SHEETS 1	SHT. No. 1
AMENDMENTS	APPROVED		DRAWING No.
OFD/DO/002	<i>JMM</i> D. O.	<i>N.K. Vijaya</i> AWM/TS	MCT-1877

MCT-1881

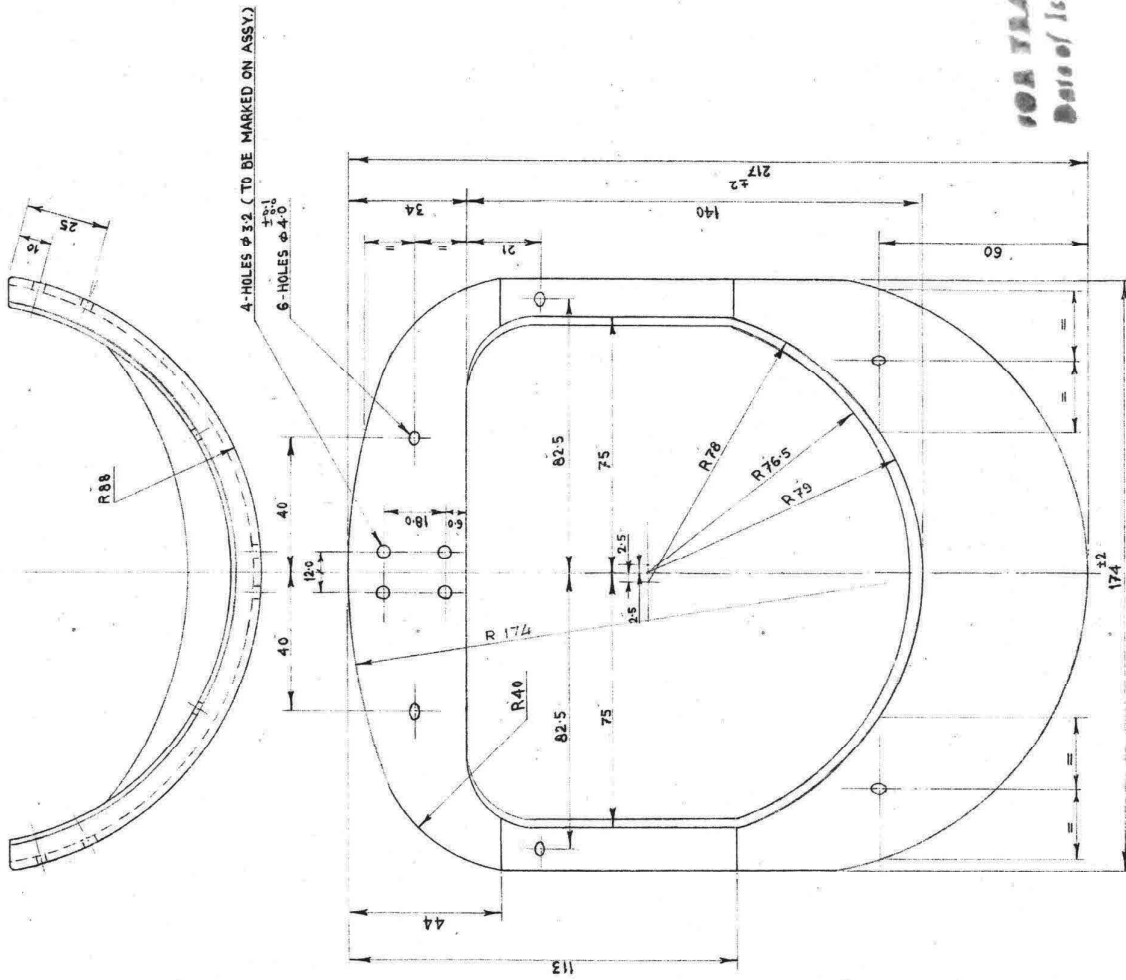

FOR TRADE ONLY
Date of Issue 14/06/24
Rajon

ALL DIMENSIONS ARE IN MM.

ORDNANCE FACTORY
DEHRADUN

DR. *Rajon*

TR.
CH. APPROVED

JWM/DO
ANIM/TS

DRG. No. IRDE-2016/26

FACE MASK GOGGLES NIGHT VISION PASSIVE 102A

FRAME

DT. 7-12-2000 SCALE: 1:1

MATL. TREAT

F.P.P. O.G. COLOUR
MATT. FINISH

SHT. NO. 1 SHTS. 1

DRAWING NO. MCT-1881

AMENDMENTS.
OPD/DO/002

ORDNANCE FACTORY, DEHRADUN

L/OUT No.

FACE MASK, GOGGLES N.V.P. 102 A.

PACKING PIECE (a)

DRG. No
IRDE 2016/21

THIRD ANGLE PROJECTION

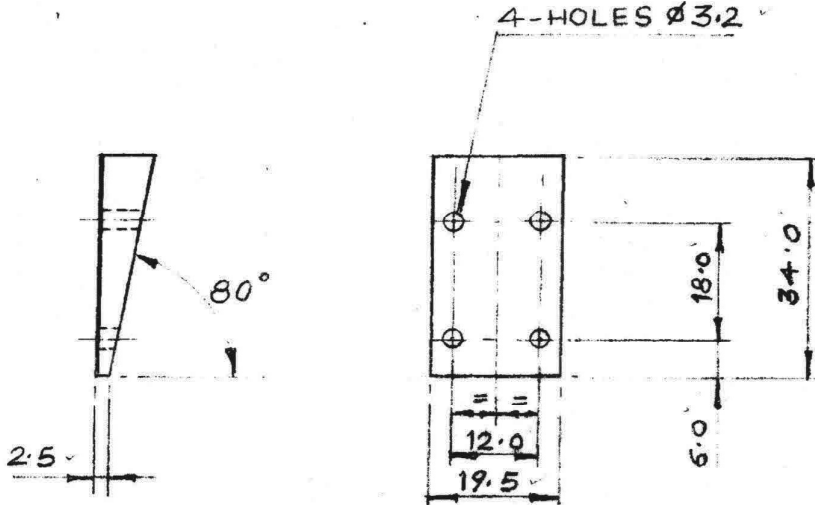
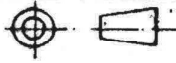

FOR QUOTE ONLY

Date of Issue: 11/06/24
[Signature]

(a)

MATL: HYLAM BLACK COLOUR, 15:2036-1974 Gde P3.

FINISH: CLEAN.

DIMENSIONS ARE IN M/M.
IMPORTANT DIMENSIONS MARKED THUS ⊕
INFORMATION MARKED THUS † TO BE MARKED ON

		DATE-30/11/2000	SCALE-1:1
DR- <i>[Signature]</i>	MATL.	TREAT.	
TR-	AS ABOVE	AS ABOVE	
CH- <i>[Signature]</i>	SHEETS 1	SHT. No. 1	
(a) D.A. No. 10/2015 DT. 27.1.2015	APPROVED		DRAWING No.
AMENDMENTS	<i>[Signature]</i>	M.K. Vijra	MCT- 1884/1
OFD/DO/002	JWA/D. O.	AWM/TS	

ORDNANCE FACTORY, BEHRADUN

L/OUT No.

FACE MASK, GOGGLES N. V.P. 102 A.
SUPPORT PIECE

DRG. N^o
IRDE 2016/20

THIRD ANGLE PROJECTION 

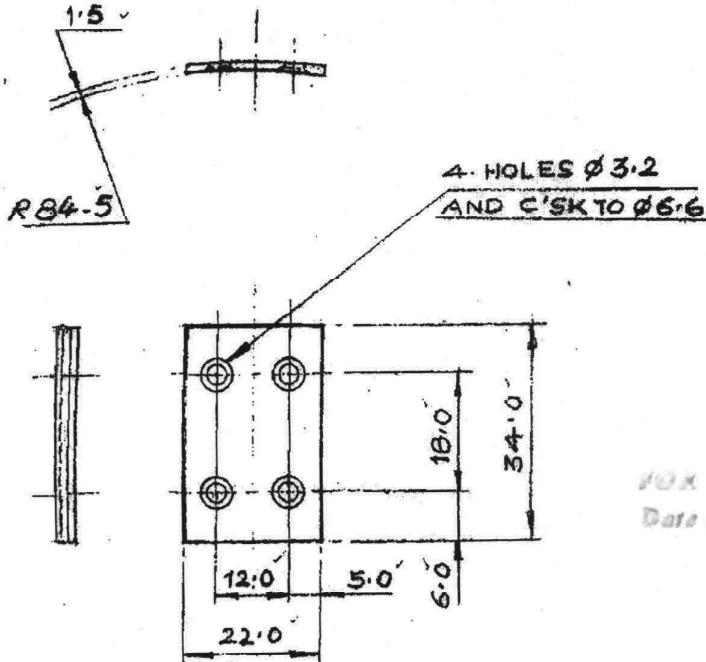

FOR TRADE SHM

Date of Issue 11/06/21

Revised

(a) MATL :- ALUMINIUM ALLOY IS: 737-1986
REAFFIRMED 1991, 1900-H
OR
64430-WP
FINISH :- ANODISED DYED DULL BLACK

DIMENSIONS ARE IN M/M.
IMPORTANT DIMENSIONS MARKED THUS ⊙
INFORMATION MARKED THUS † TO BE MARKED ON.

		DATE-30 th /2009	SCALE- 1:1
DR- <i>of mjt</i>		MATL.	TREAT.
TR-		AS ABOVE	AS ABOVE
CH- <i>2</i>		SHEETS 1	SHT. No. 1
(a) D.A.N ^o . 10/2015 DT. 27.1.2015		APPROVED	
AMENDMENTS		DRAWING No.	
OFD/DO/002		MCT-1883/1	

N.K. Vijaya
N.K. Vijaya
KWH/TS
JMM/D. O.

FACE MASK, GOGGLES N.V.P. 102A

PAD CUSHIONING ^(a)

DRG.No. IRDE 2016/23

ORDNANCE FACTORY D.DUN

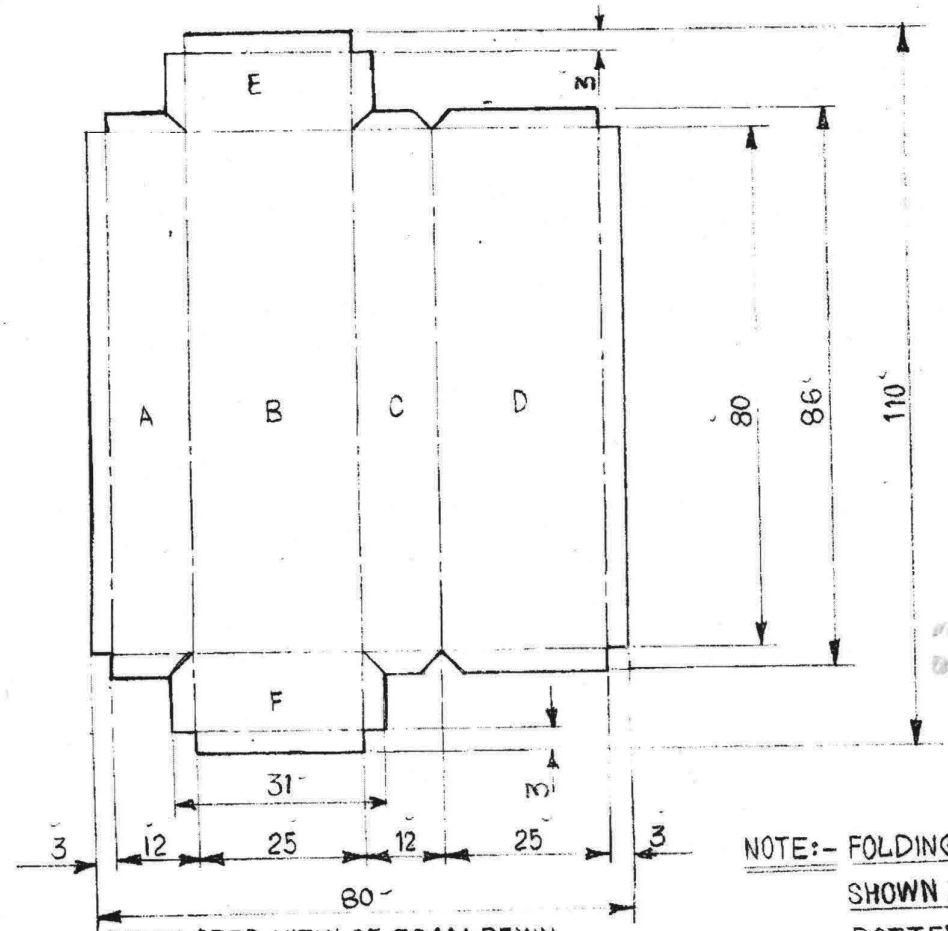

FOR TRADE PATTERN
Date of Issue 11/06/14
Ajay

DEVELOPED VIEW OF FOAM REXIN

SEQUENCE OF STITCHING

- 1- SMALL EDGE OF E TO BE STITCHED (MACHINE) WITH SMALL EDGE OF A
- 2- " " E " " " " " " C
- 3- " " F " " " " " " A
- 4- " " F " " " " " " C
- 5- BIG E " " " " " " D
- 6- " " F " " " " " " D

7-AFTER INSERTING THE PAD & FOAM THE LONG EDGE OF 'A' TO BE HAND STITCHED WITH LONG EDGE OF 'D' AS SHOWN.

	DR. <i>S. Bassi</i>	DATE 30-11-2K	SCALE:- 1:1
	TR.	MATL. FOAM REXIN BROWN COLOUR 1.0 THICK	TREAT. -
	CH.	SHEETS 1	SHEET No.1
(a) D.A.N.2 10/2015 DT. 27.1.2015	APPROVED	DRAWING No.	
AMENDMENTS	<i>(Signature)</i> N.K. Vij	MCT-1879/1	
OFD/DO/002	JWM/DO AWM/TS		

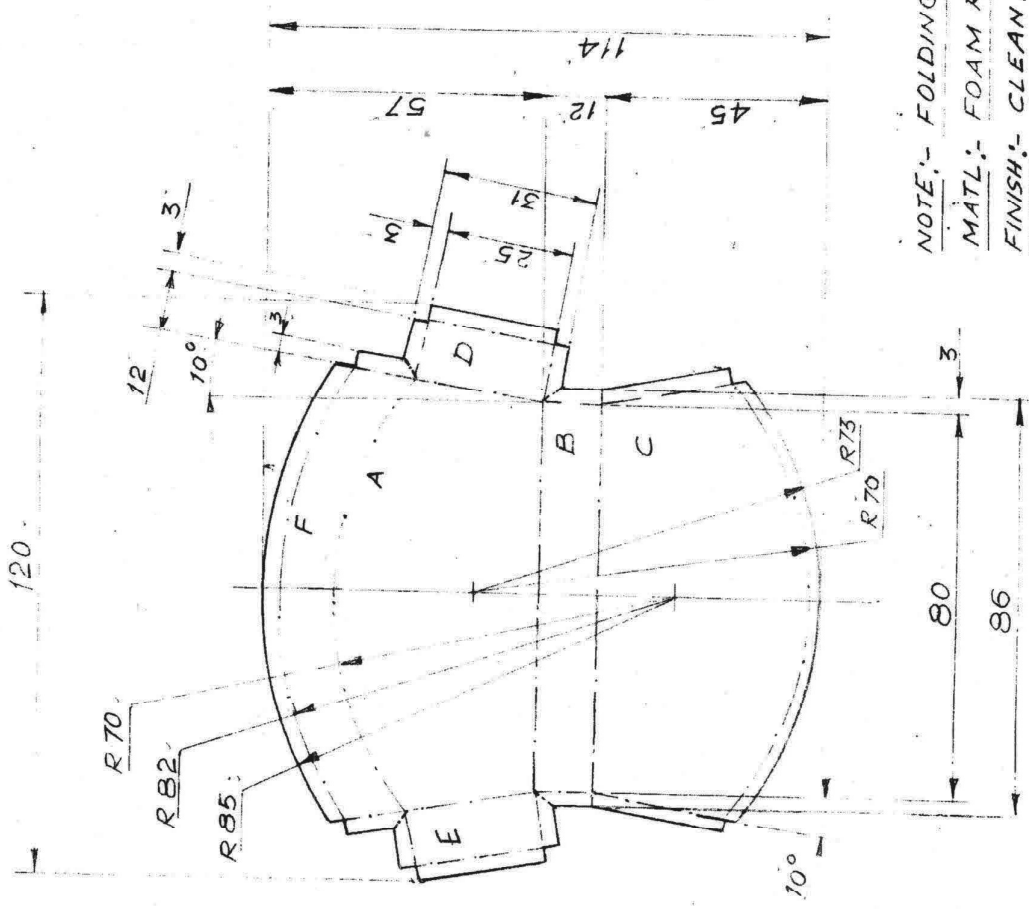

FOR TRADE COPY
 Date of Issue: 11-6-24
 M. K. V. S.

NOTE:- FOLDING LINES SHOWN IN CHAIN DOTTED.
 MATL:- FOAM REXIN, BROWN COLOUR 1/10 THICK.
 FINISH:- CLEAN.

DIMENSIONS ARE IN MM

आयुध निर्माणा
 ORDNANCE FACTORY
 धर्मपुर
 DIHRADUN

डिजाइन
 N. K. V. S.
 APPROVED
 APPROVED

FACE MASK, GOGGLES N.V.P. 102 A.

PAD CUSHIONING (CHIN) (A)

DRG. NO. IRDE 2016/24

ड्राइंग नं.	25	स्केल	1:1
मैट्रियल	AS ABOVE	कवरी	AS ABOVE
पैपर	AS ABOVE	नंबर	AS ABOVE
ड्राइंग नं.	27-115	ड्राइंग नं.	1
अमेन्डमेंट्स	CR. No.	ड्राइंग नं.	1860/1
ड्राइंग नं.	1860/1		

