

ALL DIMNS. ARE IN mm.  
UNTOL DIMNS. ARE AS PER IS:2102.

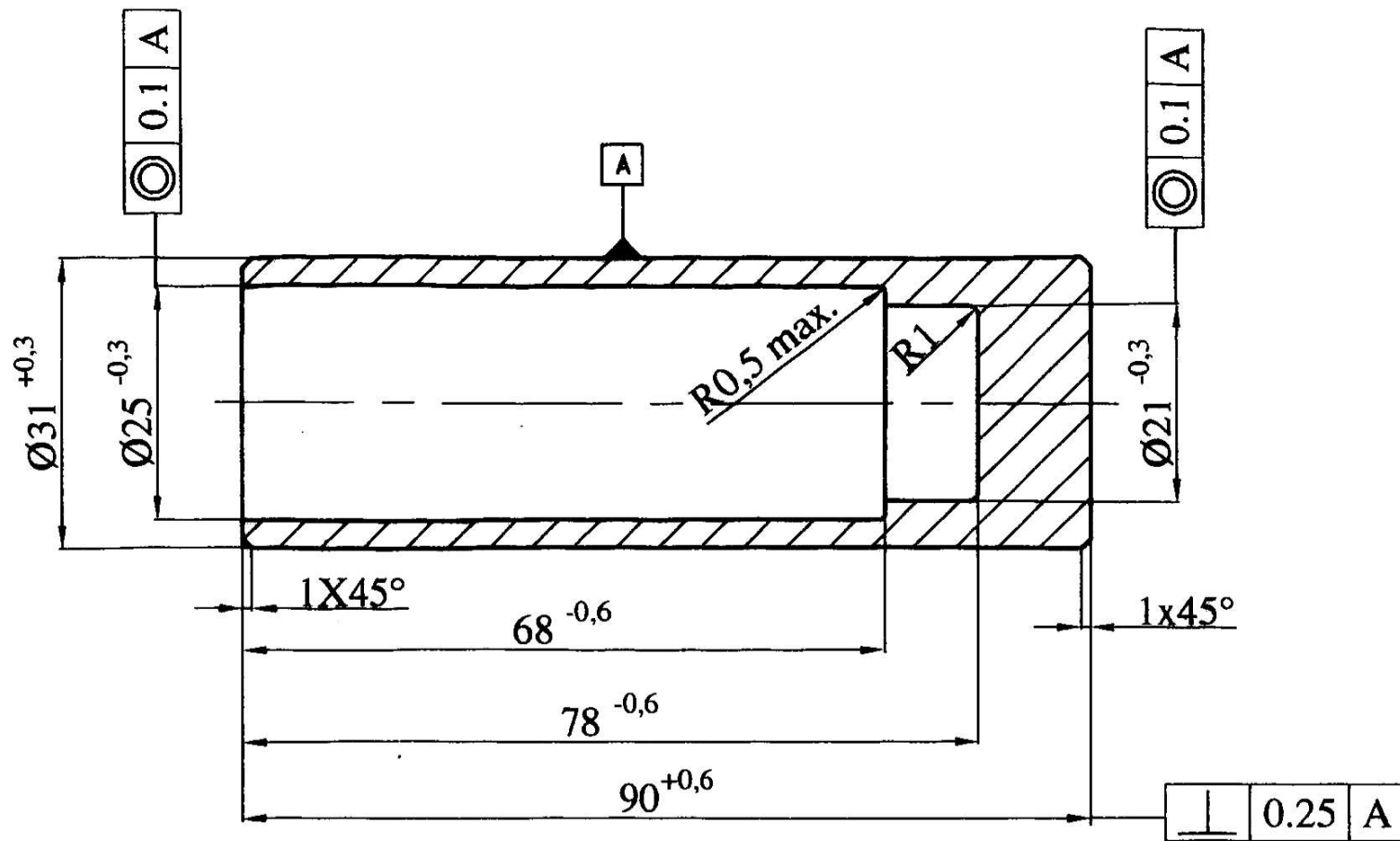

**NOTES:-**

- 1) ALL SHARP EDGES TO BE REMOVED
- 2) COMPONENT SHOULD BE MANUFACTURED EITHER BY IMPACT EXTRUSION OR BY COLD DRAWING OR BY FORGING OR BY MACHINING FROM SOLID BAR
- 3) COMPONENT TO BE SUPPLIED IN HEAT TREATED TO 'R' CONDITION.
- 4) HARDNESS TO BE ACHIEVE 230 TO 255 VPN ALLOVER (INCLUDING BASE) AFTER MACHINING  $\varnothing 31(\text{OD})$  TO  $\varnothing 29.60^{-0.1}$
- 5) SURFACE FINISH 6.3/ALL OVER
- 6) MATL. SPECH.: - STEEL 080 M40 TO BS. 970-PT, 1-1983

BASED ON O.F. Ambajhari DRG. NO. FS-1813

	SCHEDULE NO :	COMPT- GRENADE BODY 30mm HE GRENADE RURDA(AGS-17)	STORE DRG NO.	
	SCALE :		9102-00-02-00-00-000-00TA	
	DRAWN BY :		<b>BLANK</b> (SEMIFINISHED)	
	CHECKED BY :			
APPROVED BY :				
DRG. NO. :- M-11220				
DT. & SG.	DESCRIP	CONCURRED BY: JWM/dh	M/C:	NO. OF SHTS.
AMENDMENTS	DATE: 29/11/17	SIGN.: [Signature]	G. & S. FY. COSSIPORE	SHT. NO. :