

D S CAT No.:-

5306 - 009325

DIMENSIONS ARE IN MM.

REPRODUCED FROM ORIGINAL.

~ UNLESS OTHERWISE SPECIFIED

NOTES:-

- 1- SHARP EDGES SHOULD BE BLUNTED TO RAD \approx 0.6 mm.
- 1a- HEAT TREATMENT GROUP I-KT 40-05T3-1686-80.
- 2- TO BE PHOSPHATED AND SOAKED WITH OIL.
- 3- BOLT HEAD IS ALLOWED TO BE MANUFACTURED BY STAMPING. OUT-OF-SQUARENESS OF HEAD BASE SURFACE WITH BOLT AXIS SHOULD NOT EXCEED 1°.
- 4- UN-THREADED PORTION OF BOLT SHOULD BE MACHINED TO BOLT DIAMETER FOR THREAD ROLLING.

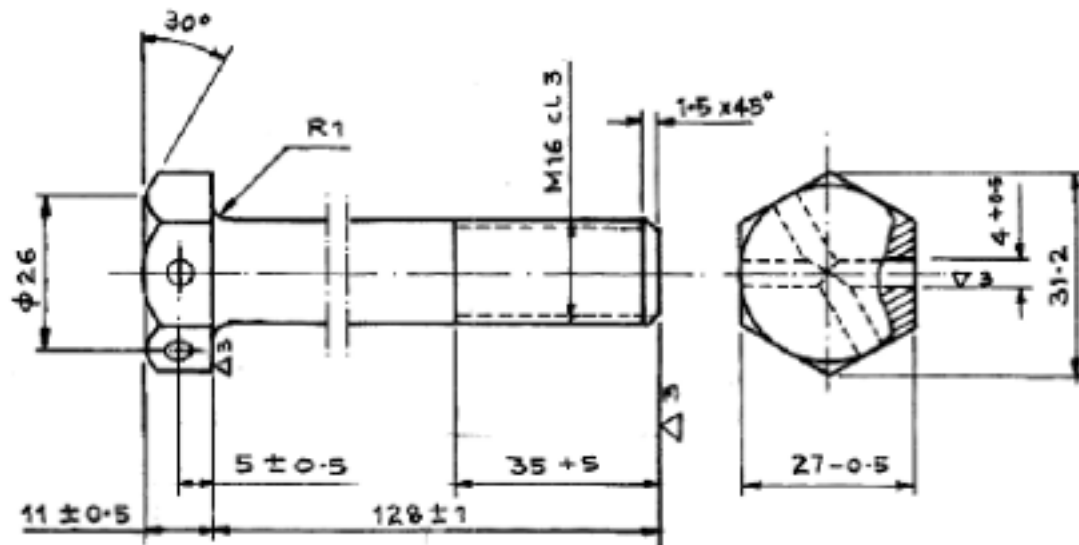

POSSIBLE ALT. MATL.:- STEEL 080M40, BS 970PT I:1983, CONDITION 'R' OR 40 C8, IS 5517-78 TO ACHIEVE REQUIRED PROPERTIES RS 63mm.

COATING:- PHOSPHATING TO SPEC. J55 0465-01 CLASS II FINISH IS (1/2).

MATL.:- HEXA HEDRON 27-5 GOST B 560-78 40-T GOST 1051-73

ID = 562
01-02-05

2210-03	18814-W	HINDI NOMENCLATURE ADDED.		DRAWN:-	CHD:-	ASSY DRG:-
7-2-93		RETRACTED WITHOUT CHANGE		TRACED:- RKR	CHD:- SKG	DATE:- 12-4-84
		PREV. DC Nos:- 16313-W, 16881-W, 16982-W, 17068-W, 17142-W & 17224-W DT. 1-15-92		C/D MAN	DO	SCALE:- 1:1
DATE	AUTHORITY	ZONE	NATURE	SIG AKSP	SIG DO	FOR CQA(W)
AMENDMENTS				MATT:- AS SHOWN ABOVE		
DRG SEALED DC No.:- 17068-W				PROT. FINISH:-		
DATE:- 7-5-91				DO CQA(W)		

CQA(AVA) AVADI

DESIGN No.:-
PART No.:-
2A 26-01-26

BOLT M16 x 128 बोल्ट

D S CAT No.:-
5306 - 009325