

DS CAT No. **5330-024789**  
 DRG CONVENTIONS CONFORMS TO IS:696.  
 DIMENSIONS ARE IN mm

**NOTES:-**

1. XXX MANUFACTURER 'S INITIALS TO BE EMBOSSSED IN 3mm x 0.5mm HIGH CHARACTERS.
2. FOR OVERSIZE HP CYLINDERS, RING (DS CAT No 1015-000606) SHOULD BE USED ALONGWITH TO DS CAT No 5330-002288
3. (i) STORE WILL BE PACKED IN A SEALED A PLOYTHENE BAG DULY TAGGED WITH A LABEL CONTAINING THE FOLLOWING DETAILS:-
  - (a) MANUFACTURER'S INITIAL.
  - (b) BATCH/ LOT No.
  - (c) MONTH & YEAR OF MANUFACTURE
- (ii) THE ABOVE SEALED BAG WILL BE HOUSED IN A SUITABLE CARTON. THE CARTON WILL BE STAMPED WITH MANUFACTURER'S INITIAL AND DS CAT / PART No OF THE STORE OR A LABEL CONTAINING THESE DETAILS WILL BE PASTED OVER THE SAME

**MATERIAL:-**

1. PACKING CANVAS IMPREGNATED ACRYLONITRILE BUTADIANE RUBBER COMPUnds TO SPEC JSS: 9320-24-2014 (REV No 1, DC 5361-ME DATED 28 JUL 2015) GRADE 'D'
2. FABRIC REFERENCE No 2 TO SPEC BS: 1103-1989 WITH SPECIAL REQUIREMENT OF ELONGATION AT BRAKE 30% MAX IN BOTH WRAP AND WEFT DIRECTION.
3. RING TO BE MANUFACTURED AND TESTED AS PER SPEC WPN/GEN/9 ( I)
4. HARDNESS ON THE FINISHED STORE 90° - 100° BS.
5. EXTENT OF CANVAS IN FINISHED STORE 40 TO 50% AS PER CQA (ME) TEST METHOD No CQA (ME) / LAB TEST METHOD / 2015/ 01 DATED 29-10-15.

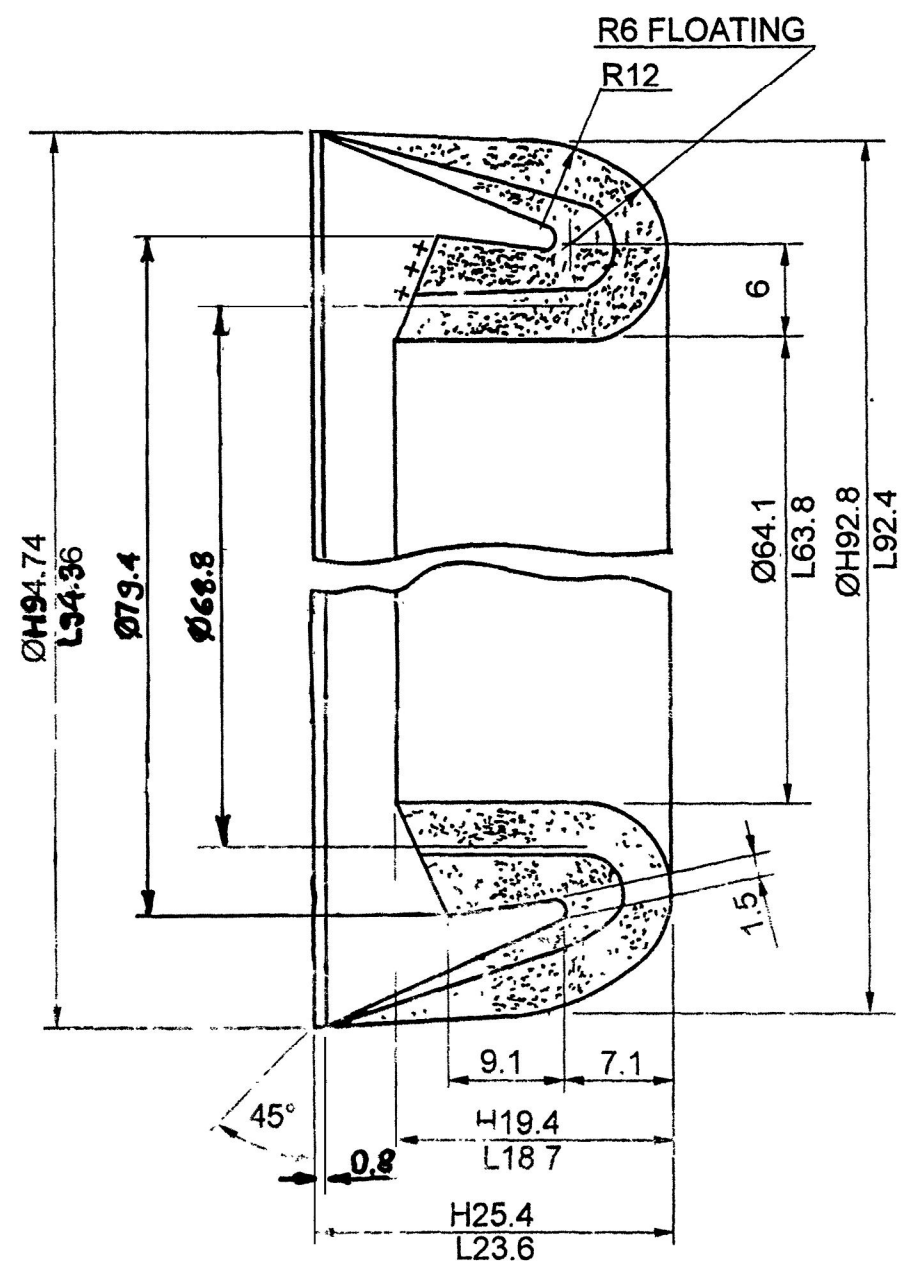
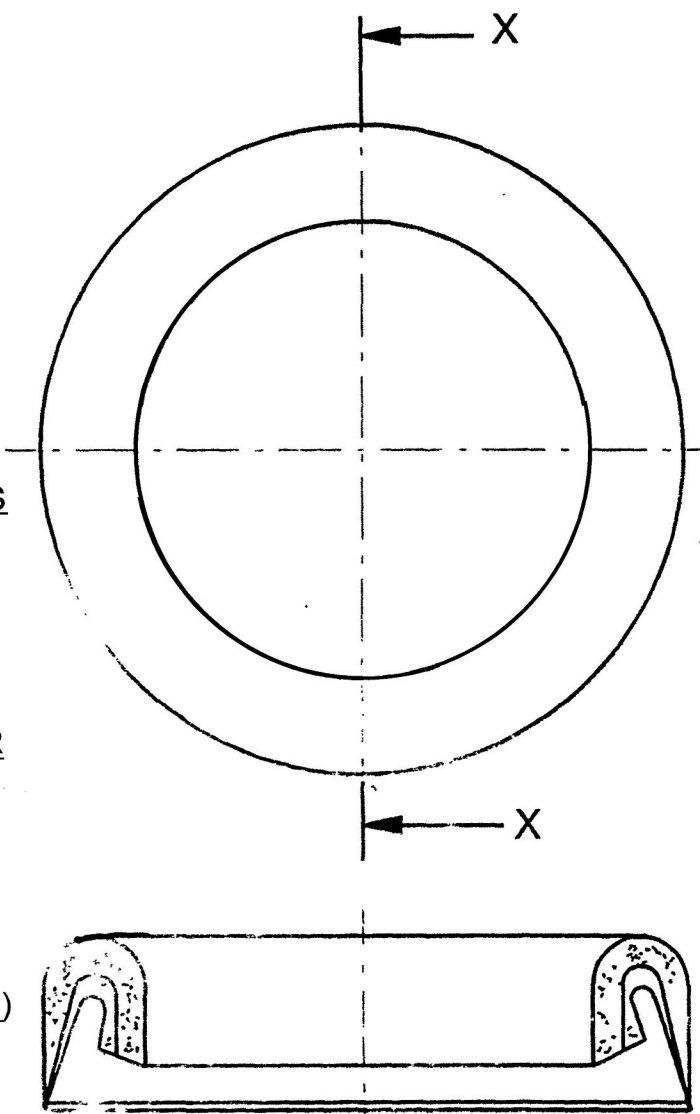

**SECTION X - X**

18-4-09	13715-W	ZONE F/5-7 NOTE ADDED & ZONE C/8-5		
7-12-15	19464-W	MATL SL No 1 & 5 AMENDED		
24-6-15		SCANNED & PRINTED WITHOUT CHANGE		
DATE	AUTHORITY	ZONE	AMENDMENTS	SIG AHSP / SIG DO
PREV DC Nos.- 15961-W, 16095-W, 16096-W, 16335-W, 17101-W, 18006-W, 18489-W, 18494-W, 18584-W, 18736-W, 18819-W, & 18841-W DATED:- 24-12-03.				
DRG SEALED:- 16095-W DATED 23-12-83				

DRAWN:-	CHD:-	ASSY DRG.- 1015 00601
SCANNED:- MK	CHD:- P.R. Vagh	DATE:-
H O S	DO	FOR CQA(W)
ESTD mass:-		

<b>CQA(W), JABALPUR</b>	
DESIGN No.	D6P-310907
PAR. No.	IFL 7423
DS CAT No.	5330-024789

MATERIAL:-  
 PROTECTIVE FINISH:-  
**PACKING PREFORMED**  
**पैकिंग प्रीफार्मड**