

2A42.07010C5

2A42.07040

3-2A42.1429-061128.13.83 41-401-84 02-288881

143 № 0001	1507 4 3010	1160 № 0001	1007 11 0001
132 1x	1507 4 3010	1160 № 0001	1007 11 0001

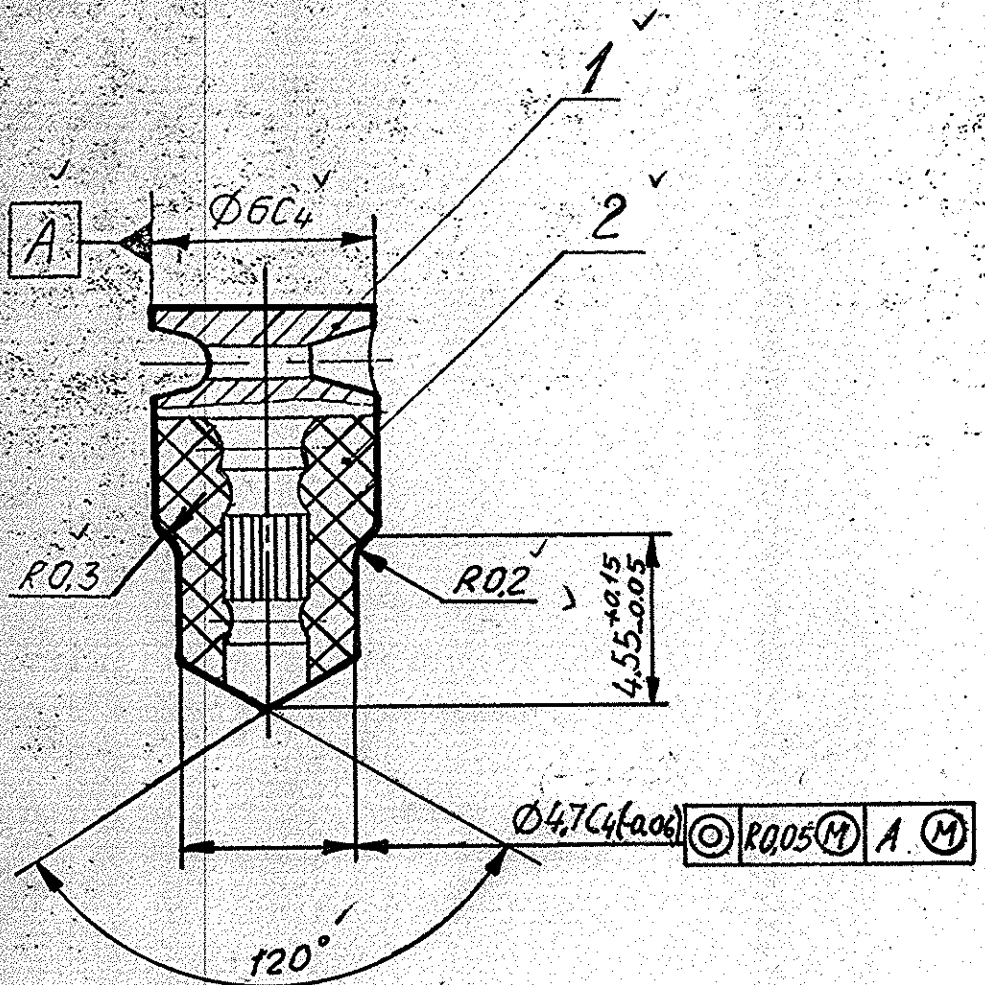

### FIRING PIN

#### Assembly Drawing

Scale 5:1. Mass: 2 g

- (1) 1. ~~Material substitute - HCB-2-P-2M, mark O, FOOT 17478-72~~ <sup>④</sup> <sup>ⓐ</sup>
- 3. Surface of part, Ref. No. 1, may project over surface of pressmaterial, Ref. No. 2, by 0.2 mm, max.
- 4. Dress gate  $R_{2.40}$  flush with part, Ref. No. 2.
- 5. Remove bulged pressmaterial on surface of part, Ref. No. 1.
- 6. Stamp K on the lot tag
- 7. For the rest of technical requirements, refer to OCT 4.FO.005.051

④ 1. ALTERNATE MATERIAL : MOULD ACB-4-P-2M-0  
TO GOST 17478-72

2. STRIKERS FROM THE ARTICLE 9-A-472 [ASSY 02-9]  
MAY BE USED.

FINAL DRG. FOR MFR. AT OFT  
DATE 15/2/93

UP-DATED: *188*  
CHECKED: *Dolphin*  
YF/M-PROJ: *M...*  
SCT: *копия Верна 10.02.93*  
DGM/PROJ: *Py...* 15.02.93

α- 1157/2A42-5. *15.02.93*

2A42

2A42.07.010C5

Боек

Сборочный чертеж

	Масса	Масштаб
0,1	2г	5:1
Лист	Листов 4	