

PART NO.
172-12-031/F (A)

ISS	MODIFICATION	DATE
A	REDRAWN TO SCALE BY SUPER IMPRESSING MACHINING OPERATION PART NO. 172-12-031/F WAS 172-12-001/F REF. 03512 (7) / PDO / T-72 / 98 Dt 28.4.98	19/12/99

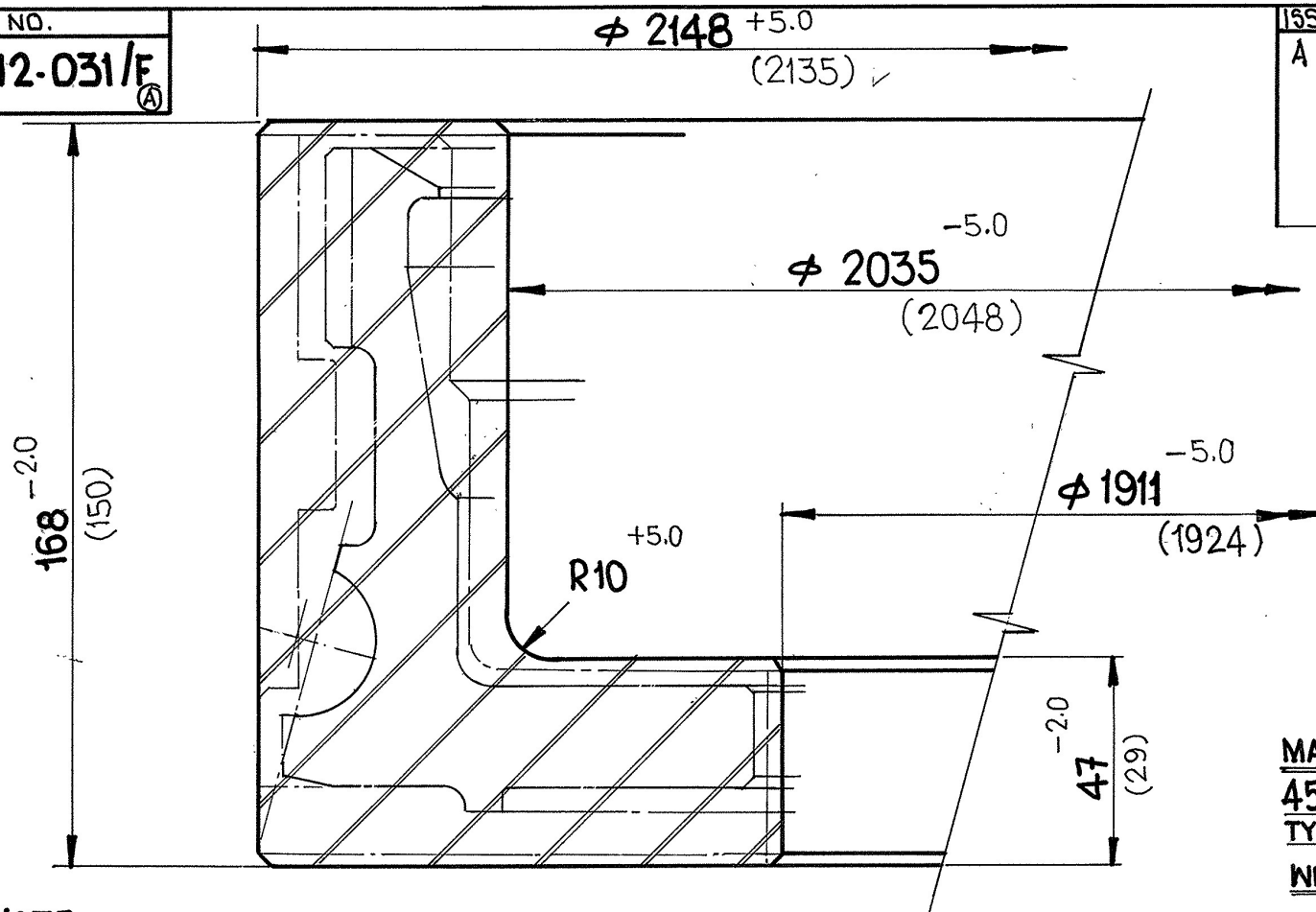

MATERIAL
45XHM
TY-14-1-2982-80
WEIGHT : 675 KGS APPROX.

NOTE

FORGINGS ARE TO BE SUPPLIED IN ROUGH MACHINED CONDITION.
ALL TECHNICAL REQUIREMENTS SHOULD CONFIRM TO **TY-14-1-2982-80**.
MACHINING DIMNS ARE SHOWN IN BRACKETS.
ALL DIMNS ARE IN MM.

SCALE	COMPONENT	FG. WT	MATERIAL
1:1	RING RACE UPPER	675 KGS APPROX.	45XHM TY-14-1-2982-80
THIS DRG IS USED WITH J&T D.O. SPECN. II JT ISS. NIL			H.V. FACTORY, AVADI
DRN.	CHD.	APPD.	AUTHD.
BLANK SIZE FOR RING RACE UPPER			172-12-031/F