

DRG. NO. SK-6506/TE

SK-6506/TE

Hos/mm

D.A. NO.

$\sqrt{Rz} 20 (\checkmark)$

20.7.23

Handwritten signature and date

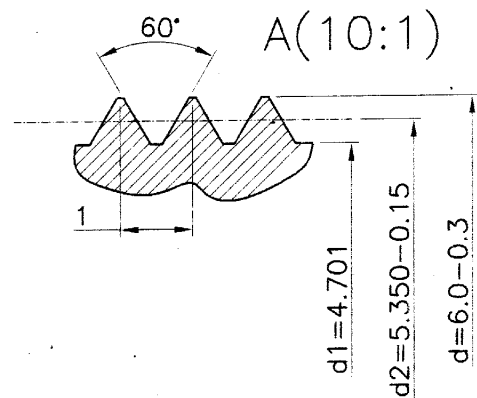
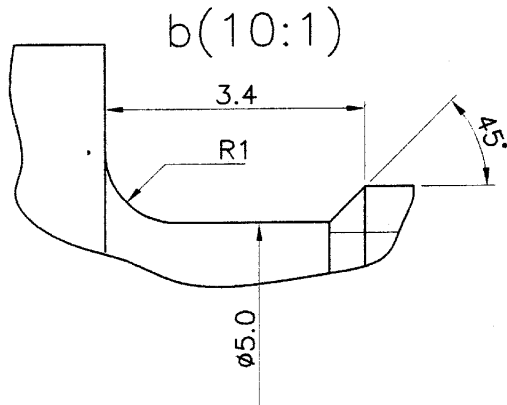
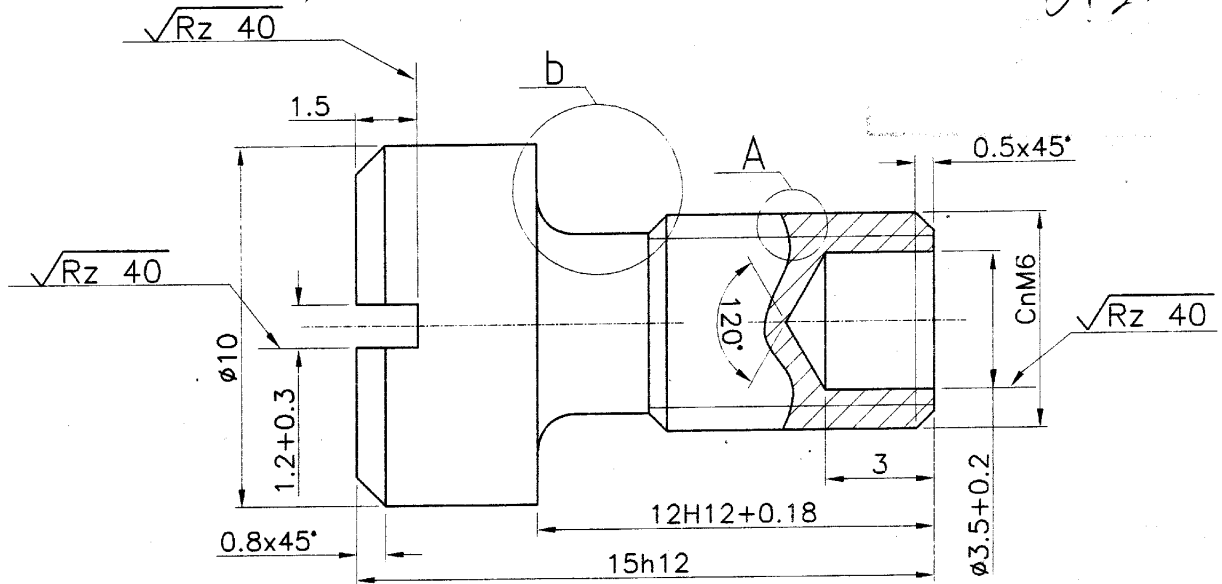

- 1 38...45HRC. Hardness to be tested using witness sample.
- 2 Unspecified tolerance according to 6745-1.CDTY/E2.
- 3 Coating is Chem. Phos. chr/impreg. with bφ-4glue GOST 12172-2016 with nigrosine grade A GOST 9307-78.
- 4 Stamp K,И on lot label.

**7.62X39mm AR-SAF
Screw**

DRAWN.	TRACED	CHECKED
--------	--------	---------

S.P.SONI		
----------	--	--

DATE	29.05.2023
------	------------

APPROVED

HOS/DDO

DRAWING NO.

SK-6506/TE

SHEET 1 OF 1

SCALE

N. T. S.



**SMALL ARMS FACTORY
KANPUR**